

August 2019

Deaf Cultural Socialization: Exploring the Role of Parents in Deaf Cultural Identity Development

Macrae Husting
University of Wisconsin-Milwaukee

Follow this and additional works at: <https://dc.uwm.edu/etd>

 Part of the [Developmental Psychology Commons](#), [Educational Psychology Commons](#), and the [Ethnic Studies Commons](#)

Recommended Citation

Husting, Macrae, "Deaf Cultural Socialization: Exploring the Role of Parents in Deaf Cultural Identity Development" (2019). *Theses and Dissertations*. 2195.
<https://dc.uwm.edu/etd/2195>

This Dissertation is brought to you for free and open access by UWM Digital Commons. It has been accepted for inclusion in Theses and Dissertations by an authorized administrator of UWM Digital Commons. For more information, please contact open-access@uwm.edu.

DEAF CULTURAL SOCIALIZATION:
EXPLORING THE ROLE OF PARENTS IN
DEAF CULTURAL IDENTITY DEVELOPMENT

by

Macrae Husting

A Dissertation Submitted in
Partial Fulfillment of the
Requirements for the Degree of

Doctor of Philosophy
in Educational Psychology

at

The University of Wisconsin-Milwaukee

August 2019

ABSTRACT

DEAF CULTURAL SOCIALIZATION: EXPLORING THE ROLE OF PARENTS IN DEAF CULTURAL IDENTITY DEVELOPMENT

By

Macrae Husting

The University of Wisconsin-Milwaukee, 2019
Under the Supervision of Professor Jacqueline Nguyen

There is an assumption in the Deaf identity literature that suggests that parents' hearing status determines the cultural identity and well-being of deaf and hard of hearing individuals. This dissertation uses the ethnic-racial socialization framework to challenge this assumption. It does so by proffering an alternative explanation of the role that parents play by introducing two forms of socialization as mechanisms through which parents influence their child's cultural identity development and well-being. *Deaf cultural socialization* is the process by which parents transmit messages to children regarding the importance and meaning of Deaf culture and membership in the Deaf community. *Minority status socialization* is the process by which parents transmit messages to children regarding how to advocate for themselves and cope with discrimination they may face as a deaf person in a Hearing world. Using social identity theory as a foundation and ethnic-racial socialization and identity research as a framework, this dissertation explores whether the associations between socialization and outcomes found in the ethnic-racial literature generalize to the Deaf culture.

To explore this, 305 deaf and hard of hearing emerging adults from the United States completed an online survey consisting of two new measures of socialization (developed for this study), and measures of cultural identity, self-esteem, satisfaction with life, and depression/anxiety. Hearing

and deaf parents engaged in socialization to an equal degree. Both Deaf cultural socialization and minority status socialization were strong predictors of cultural identity, self-esteem, and satisfaction with life, while controlling for parents' hearing status, relationship with parents, and relevant demographic characteristics. Socialization did not predict depression/anxiety. Parents' hearing status only predicted self-esteem. Therefore, the assumption in the literature overestimates the influence of parents' hearing status while it underestimates the role of parents as agents of socialization in shaping cultural identity and well-being outcomes. Hearing parents, like transracially adoptive parents, promote identity development of an *unshared* culture through their socialization practices. More research is needed to address the gap in the literature by continuing to apply developmental theories, models, and measures to Deaf cultural identity. Doing so will develop a more nuanced understanding of the Deaf cultural community and allow professionals to tailor services to support hearing parents as they raise culturally different children.

© Copyright by Macrae Husting, 2019
All Rights Reserved

For my boys, Henry and Sullivan.

Persevere, my darlings.

“The man who moves a mountain begins by carrying away small stones.” -Confucius

“Perseverance is the hard work you do after you get tired
of doing the hard work you already did.” -Newt Gingrich

“How long should you try? UNTIL!”- Jim Rohn

TABLE OF CONTENTS

Chapter

I.	INTRODUCTION.....	1
	Deaf Cultural Identity.....	1
	Parental Socialization, Cultural Identity, and Well-Being.....	3
	Ethnic-racial socialization and identity.....	4
	Unshared cultural socialization and ethnic-racial identity.....	5
	Deaf cultural socialization.....	6
	Parent' Hearing Status, Cultural Identity, and Well-Being.....	7
	Significance of the Problem.....	9
	Problem statement.....	9
II.	LITERATURE REVIEW.....	11
	Theoretical Foundation: Social Identity Theory.....	11
	Deaf Culture.....	12
	Deaf Cultural Identity.....	16
	Ethnic-Racial Identity Development Framework.....	17
	Deaf Identity: The Developmental Model.....	20
	Immigrant Acculturation Framework.....	22
	Deaf Identity: The Acculturation Model.....	23
	The Significance of Cultural Identities.....	24
	Ethnic-racial identity and outcomes.....	24
	Immigrant acculturation and outcomes.....	25
	Deaf identity development model and outcomes.....	25
	Deaf acculturation model and outcomes.....	25
	Two Explanations of the Role of Parents in Deaf Cultural Identity Development.....	27
	Parents' hearing status hypothesis.....	27
	Contradictory evidence.....	32
	The socialization hypothesis: Deaf cultural socialization.....	35
	Ethnic-Racial Minority Families: Transmitting a Shared Culture.....	36
	Ethnic-racial socialization and ethnic-racial identity.....	41
	Transracially Adoptive Families: Transmitting an Unshared Culture.....	43
	Deaf Cultural Socialization Scale	45

Constructs of Interest in the Current Study.....	51
Socialization.....	52
Cultural identity.....	53
Self-esteem.....	54
Satisfaction with life.....	55
Mental health: depression/anxiety.....	56
Parents' hearing status.....	56
Relationship with parents.....	57
Sociodemographic characteristics.....	58
The Present Study.....	59
Research Question and Hypotheses.....	60
III. METHOD.....	62
Research Design.....	62
Procedure.....	62
Recruitment.....	62
Participants.....	64
Sociodemographic characteristics of the analytic sample.....	66
Demographic characteristics.....	67
Hearing/language-related characteristics.....	67
Family characteristics.....	69
School characteristics.....	70
Unique Sample Qualities.....	72
Comparisons.....	72
Education.....	73
“Less deaf”.....	73
Cultural Identity Differences.....	74
Construction of the Scales.....	75
Measures.....	81
Independent variables.....	81
Deaf cultural socialization.....	81
Minority status socialization.....	81

Dependent Variables.....	81
Cultural identity.....	81
Self-esteem.....	84
Satisfaction with Life.....	84
Depression/Anxiety.....	84
Control Variables.....	85
Parents' hearing status.....	85
Relationship with parents.....	85
Sociodemographic characteristics.....	86
Analytic Plan.....	86
IV. RESULTS.....	88
Preliminary Analyses: Factor Structure, Reliability, and Validity.....	88
Deaf Cultural Socialization Scale.....	88
Minority Status Socialization Scale.....	94
Validity of the DCSS and MSS.....	96
Predictive validity.....	96
Concurrent validity.....	97
Discriminant validity.....	98
Descriptive Analyses.....	99
Acculturation.....	99
Parents' hearing status and study variables.....	101
Differences in DCSS and MSS by sociodemographic characteristics.....	102
Correlations between study variables.....	105
Sociodemographic characteristics and outcome variables.....	106
Deaf acculturation.....	108
Hearing acculturation.....	108
Self-esteem.....	109
Satisfaction with life.....	109
Research Question: How is Socialization Associated with Cultural Identity and Well-Being Outcomes?	109

Hypothesis 1a: Socialization (i.e., DCSS or MSS) predicts cultural identity (i.e., Deaf acculturation)	112
Deaf cultural socialization and Deaf acculturation.....	112
Minority status socialization and Deaf acculturation.....	112
Deaf cultural socialization and Hearing acculturation.....	115
Minority status socialization and Hearing acculturation.....	115
Hypothesis 1b: Socialization (i.e., DCSS or MSS predicts cultural identity (i.e., cultural identity status)	117
Deaf cultural socialization and cultural identity status.....	117
Minority status socialization and cultural identity status.....	118
Hypothesis 2: Socialization (i.e., DCSS or MSS) predicts self-esteem.....	119
Deaf cultural socialization and self-esteem.....	119
Minority status socialization and self-esteem.....	121
Hypothesis 3: Socialization (i.e., DCSS or MSS) predicts satisfaction with life..	121
Deaf cultural socialization and satisfaction with life.....	123
Minority status socialization and satisfaction with life.....	123
Hypothesis 4: Socialization (i.e., DCSS or MSS) predicts depression/anxiety (negatively)	124
V. DISCUSSION.....	125
The Sample.....	125
Recruitment differences.....	126
Sociodemographic differences.....	127
Education.....	127
“Less deaf”.....	128
Cultural identity differences.....	128
Summary of Results.....	130
Socialization predicted cultural identity and well-being outcomes.....	130
Parents’ Hearing Status was a poor predictor of outcomes.....	131
Analyses of Key Findings.....	131
The role of parents in Deaf cultural identity development: agents of socialization.	131

Parents as agents of socialization.....	132
Parents' hearing status as a predictor.....	133
Parents hearing status as a moderator.....	134
Quality of the remembered relationships with parents.....	134
The ethnic-racial socialization literature applies to Deaf cultural identity development.....	135
Ethnic-racial framework: Deaf cultural socialization predicts Deaf cultural identity development.....	135
Multicultural family framework: Hearing parents engage in unshared cultural socialization, which predicts psychosocial outcomes.....	136
Deaf cultural identity and developmental research.....	137
Contributions and Implications.....	138
Challenging the parents' hearing status hypothesis.....	138
Applying and demonstrating the utility of the ethnic-racial socialization model.....	139
Developing a measure of Deaf cultural socialization.....	140
Unique sample.....	140
Future Research.....	141
Sampling.....	141
Measurement.....	141
The Minority Status Socialization Scale.....	141
The Deaf Cultural Socialization Scale.....	143
Hearing Acculturation.....	144
Moderation.....	144
Socialization and positive parenting.....	144
Relationship with parents.....	145
Child perception of socialization.....	145
Antecedents of socialization.....	146
Mental health.....	147
Deaf cultural identity.....	147
Limitations.....	148

Assumption violations.....	148
Unique sample.....	149
Sample sizes.....	149
Exploratory.....	149
Correlational design.....	149
Author's hearing status and cultural identity.....	150
REFERENCES.....	152
APPENDICES	
A Consent Form.....	174
B Survey Items Regarding Sociodemographic Characteristics.....	176
C The Deaf Cultural Socialization Scale.....	180
D The Minority Status Socialization Scale.....	183
E The Deaf Acculturation Scale.....	184
F The Rosenberg Self-Esteem Scale.....	187
G The Satisfaction with Life Scale.....	188
H The Patient Health Questionnaire.....	189
I The Remembered Relationship with Parents Scale.....	190
J Exploration of the Modes of Transmission.....	191
K Cultural Identity Status and the Study Variables.....	194
L Parents' Hearing Status Dichotomized and Study Variables.....	196
M Post Hoc Comparisons of Group Differences in DCSS and MSS.....	198
N Parents' Hearing Status as a Moderator.....	202
O Content Analysis of the Minority Status Socialization Scale.....	204
P DCSS Items by Source and Mode of Transmission.....	207
Q School Level and Primary Agent of Socialization.....	208
CURRICULUM VITAE.....	212

LIST OF FIGURES

- Figure 1. Confirmatory Factor Analysis for 12 adapted Family Ethnic Socialization Measure items. Standardized factor loadings on arrows and portion of variance explained in superscripts.....89
- Figure 2. Confirmatory Factor Analysis for 20-item Deaf Cultural Socialization Scale. Standardized factor loadings on arrows and portion of variance explained in superscripts.....91

LIST OF TABLES

Table 1. Summary of ANOVA Comparing Means of the Excluded Sample (N=126) and the Analytic Sample (N=305) Across the Primary Study Variables.....	65
Table 2. Demographic Characteristics of the Present Study (Husting; N=305) and Comparison Data from the Gallaudet Research Institute's (GRI) 2009-2010 Annual Survey of Deaf and Hard of Hearing Children and Youth, National Data.....	67
Table 3. Hearing/Language-Related Characteristics of the Present Study (Husting; N=305) and Comparison Data from the Gallaudet Research Institute's (GRI) 2009-2010 Annual Survey of Deaf and Hard of Hearing Children and Youth, National Data.....	68
Table 4. Family Characteristics of the Present Study (Husting; N=305) and Comparison Data from the Gallaudet Research Institute's (GRI) 2009-2010 Annual Survey of Deaf and Hard of Hearing Children and Youth, National Data.....	70
Table 5. School Characteristics of the Present Study (Husting; N=305) and Comparison Data from the Gallaudet Research Institute's (GRI) 2009-2010 Annual Survey of Deaf and Hard of Hearing Children and Youth, National Data.....	71
Table 6. Descriptive Summary of Cultural Identity for the Current Sample and the Studies by Maxwell-McCaw (2001 and Wolf Craig (2012).....	74
Table 7. 20-Item Deaf Cultural Socialization Scale with Source and Mode of Transmission.....	77
Table 8. 6-Item Minority Status Socialization Scale (MSS)	80
Table 9. Exploratory Factor Analysis of the 20-item Deaf Cultural Socialization Scale (DCSS); 1 Factor.....	93
Table 10. Exploratory Factor Analysis of the 5-item Minority Status Socialization Scale (MSS); 1-Factor.....	96
Table 11. Summary of Descriptive Results, ANOVA, and Post-Hoc Contrast Analyses of DCSS and MSS Across Cultural Identity Statuses.....	98
Table 12. Bivariate Correlations Among the Subscales of the Deaf Acculturation Scale- Deaf and Hearing Culture Scales and the DCSS and MSS.....	100

Table 13. Summary of Analysis of Variance Results of Group Differences in Study Variables by Number of Deaf or Hard of Hearing (D/HH) Parents.....	101
Table 14. Descriptive and ANOVA Summary of Means and Group Differences in DCSS and MSS Across Sociodemographic Characteristics.....	103
Table 15. Bivariate Correlations Among Study Variables.....	106
Table 16. Summary of Simple Linear Regression Analyses Regressing the Sociodemographic Variables on the Outcome Variables.....	107
Table 17. Summary of Hierarchical Regression Analysis Regressing DCSS or MSS on Deaf Acculturation (Steps 4a and 4b) While Controlling for Sociodemographic Variables (Step 1), Parents' Hearing Status (Step 2), and Remembered Relationships with Parents: Control and Alienation (Step 3).....	114
Table 18. Summary of Hierarchical Regression Analysis Regressing DCSS or MSS on Hearing Acculturation (Steps 4a and 4b) While Controlling for Sociodemographic Variables (Step 1), Parents' Hearing Status (Step 2), and Remembered Relationships with Parents: Control and Alienation (Step 3)	116
Table 19. Summary of Multinomial Logistic Regression Analysis with Deaf Cultural Socialization (DCSS) Regressed on the Cultural Identity Statuses.....	117
Table 20. Summary of Multinomial Logistic Regression Analysis with Minority Status Socialization (MSS) Regressed on the Cultural Identity Statuses.....	118
Table 21. Summary of Hierarchical Regression Analysis Regressing DCSS or MSS on Self-Esteem (Steps 4a and 4b) While Controlling for Sociodemographic Variables (Step 1), Parents' Hearing Status (Step 2), and Remembered Relationships with Parents: Control and Alienation (Step 3)	120
Table 22. Summary of Hierarchical Regression Analysis Regressing DCSS or MSS on Satisfaction with Life (Step 4a and 4b) While Controlling for Sociodemographic Variables (Step 1), Parents' Hearing Status (Step 2), and Remembered Relationships with Parents: Control and Alienation (Step 3)	122

Table 23. Sociodemographic Survey Items and Response Values.....	172
Table 24. Items of the Verbal and Nonverbal Subscales of Deaf Cultural Socialization Scale (Husting, in progress) Side-by-Side the Original Items from the Family Ethnic Socialization Measure (Umaña-Taylor, Yazedjian, & Bámaca-Gómez, 2004a)	180
Table 25. Items of the Minority Status Socialization Scale (MSS; Husting, in progress).....	183
Table 26. The Deaf Acculturation Scale (Maxwell-McCaw & Zea, 2011)	184
Table 27. Items of the Rosenberg Self-Esteem Scale (1989)	187
Table 28. Items of Satisfaction with Life Scale (Diener, Emmons, Larsen, & Griffin, 1985)...	188
Table 29. Items of the Patient Health Questionnaire (PHQ-4; Kroenke, Spitzer, Williams, & Löwe, 2009)	189
Table 30. Items of the Remembered Relationship with Parents (Denollet, Smolderen, van den Broek, & Pedersen, 2007)	190
Table 31. Summary of Descriptive and ANOVA Results for Verbal DCSS and Nonverbal DCSS Across Parents' Hearing Status Groups.....	191
Table 32. Summary of Correlations between Verbal DCSS, Nonverbal DCSS, and the Study Variables for the Deaf of Deaf (DoD; N=71), Deaf of Hearing (DoH; N=234), and the Total Sample (N=305)	192
Table 33. Descriptive Statistics and ANOVA Results of Each of the Study Variables across Cultural Identity Statuses.....	194
Table 34. Summary of Analysis of Variance Results of Group Differences in Study Variables by Parents' Hearing Status Dichotomized.....	196
Table 35. Summary of Multiple Regression Analyses Predicting the Outcome Variables with the Deaf Cultural Socialization Scale (DCSS), Parents' Hearing Status, and a Moderator Term...	202
Table 36. Summary of Multiple Regression Analyses Predicting the Outcome Variables with the Minority Status Socialization Scale (MSS), Parents' Hearing Status, and a Moderator Term...	203

Table 37. Summary of Bivariate Correlations Between MSS Items Categorized as Advocacy, Preparation for Bias, and Promotion of Mistrust and the Study Variables.....	205
Table 38. Summary of ANOVA Results of Group Differences in Parents' Hearing Status Across the Content of MSS Items.....	205
Table 39. Bivariate Correlations Among Study Variables and the Items Adapted from the FESM and the Additional Deaf-Specific Items.....	207
Table 40. Comparison of Socialization (DCSS and MSS Combined) Reported Across School Levels.....	208
Table 41. Correlations Between Study Variables and Socialization Received at Each Level of School.....	209
Table 42. Summary of ANOVA Results of Group Differences in Study Variables by Primary Agent of Socialization: Mother (N=210), Father (N=56), and Other Caregiver (N=37).....	209

LIST OF ABBREVIATIONS

ASL	American Sign Language
DAS	Deaf Acculturation Scale
DCSS	Deaf Cultural Socialization Scale
D/HH	Deaf or hard of hearing
DOD	Deaf of Deaf; deaf individual with deaf parent(s)
DOH	Deaf of Hearing; deaf individual with hearing parents
FESM	Family Ethnic Socialization Measure
MSS	Minority Status Socialization Scale

ACKNOWLEDGEMENTS

“All that I have achieved has been possible not only because of my own strength and perseverance, gained through hardship, but also through other people's support and belief in me.”

Clemantine Wamariya

I am filled with unending gratitude for my grandpa John “Jack” Schomaker and my late grandma Mary (Ahern) Zimmeth Schomaker who made graduate school possible financially. Thank you for the enormous gift of education. This dissertation would not exist without you.

I am extremely grateful for my children’s grandparents, Gloria and Glen Telindert, and Tom Husting and Linda Anderson, for all of the help they have provided with childcare as I have worked on this dissertation the last few years. This completed document and labor of love would not exist if I had not been able to put my children into their loving arms over and over again. Thank you for loving those boys and keeping them safe and happy while I worked.

I am grateful for the people that I have in my corner, most notably, Dave Telindert, Tom Husting, Linda Anderson, Henry Telindert, Sullivan Telindert, and my deaf friends. When I have been stressed, stretched thin, and too busy, you have been my sounding boards, my sanity, and my joy. Thank you for putting up with me.

I owe an extra thank you to my husband, Dave, who has shouldered more than his share of the burdens of caring for our family and home as I attempted to juggle priorities, deadlines, and time management. Thank you for being a wonderful husband and father. And cute to boot.

To my children, I regret the time with you that I have sacrificed and how crabby multi-tasking can make me. Thank you for enduring this time with and without me. And thank you for being so dang awesome.

I am grateful for all of the wisdom and feedback I have received from my advisor, Dr. Jacqueline Nguyen, these seven years. Her enthusiasm for my research interests enabled me to find my path and her feedback along the way allowed the seed of an idea to grow to fruition. Thank you for that direction which has gotten me here and continues to guide my way forward.

I am grateful for my committee members, Drs. Christopher Lawson, Susie Lamborn, Irene W. Leigh, and Jaqueline Nguyen, for getting through the long readings and supplying feedback to strengthen my work. Thank you for your time and contributions.

I am grateful for the Deaf identity experts who have welcomed me and replied to my many emails, especially Dr. Irene W. Leigh, who has shared her time and expertise with me from retirement. Thank you!

I am grateful for the deaf and hard of hearing individuals who shared their time and experiences by participating in this research. Thank you!

Finally, I am grateful that the little girl who loved to play school with her stuffed animals and dolls as students grew up to find a home in academia, a fascination with psychology, an identity as a researcher, and a passion for a research topic.

Chapter 1

Introduction

This dissertation explores the role of parents as agents of socialization in the cultural identity development and well-being of deaf and hard of hearing emerging adults. To do so, the literature review uses social identity theory as a theoretical foundation and the ethnic-racial socialization literature as an empirical framework. New constructs and measures of socialization related to being deaf or hard of hearing were here developed and used to predict cultural identity and well-being outcomes. This dissertation attempts to generalize the ethnic-racial socialization literature to the deaf and hard of hearing community, while also exploring the active role parents may play in well-being and Deaf cultural identity development of a sample of deaf and hard of hearing emerging adults.

Deaf Cultural Identity

Culture is defined as “the sum of attitudes, customs, and beliefs that distinguishes one group of people from another. Culture is transmitted through language, material objects, rituals, institutions, and art from one generation to the next” (Hirsch, Kett, & Trefil, 2002, p. 431). The American Deaf culture (specific to the United States) is one such culture, with a rich history of shared language (i.e., American Sign Language, ASL), experiences, values, behavioral patterns, traditions, institutions, organizations, art, political activism, and collectivism (for detailed descriptions of the American Deaf Culture, see Holcomb, 2013; Lane, 1999; Lane, Hoffmeister, & Bahan, 1996; Leigh, Andrews, & Harris, 2016; Padden & Humphries, 1988).

Cultural identity is defined as an individual’s cultural self-definition, self-perceptions and the related emotions regarding membership in a socio-cultural group, including their culturally-

based values, practices, and identification (Marschark, Zettler, & Dammeyer, 2017; Schwartz et al., 2013; Schwartz, Zamboanga, & Jarvis, 2007).

This study explores *Deaf cultural identity*, which is a cultural identity based on membership in the Deaf cultural group. Deaf cultural identity involves some degree of hearing loss, identification with cultural Deaf people, competence in sign language, internalization of Deaf cultural values and beliefs, and knowledge of and adherence to the social rules of interaction within the Deaf culture (Leigh et al., 2016; Marschark et al., 2017; Maxwell-McCaw & Zea, 2011). In this dissertation, the words *deaf* and *hearing* are capitalized when referring to a culture and lowercase when referring to an audiological characteristic.

Four categories of cultural identity are commonly used to describe deaf and hard of hearing individuals based on a combination of two cultural orientations: the degree of orientation to Deaf culture (Deaf acculturation) and the degree of orientation to the Hearing culture (Hearing acculturation). The degree of orientations to the two cultures are combined to form the four categories of cultural identity: *Marginal* (low in both Deaf and Hearing acculturation), *Hearing* (low in Deaf acculturation and high in Hearing acculturation), *Deaf* (high in Deaf acculturation and low in Hearing acculturation), and *Bicultural* (high in both Deaf and Hearing acculturation).

The different categories of cultural identity are associated with divergent well-being outcomes. Marginal identification is associated with the least healthy outcomes, such as lower self-esteem and satisfaction with life. Bicultural identification is associated with the healthiest outcomes, such as higher self-esteem and satisfaction with life. Hearing and Deaf identification tend to fall somewhere in between with mixed findings (Bat-Chava, 2000; Hintermair, 2006, 2008; Leigh, 2009; Maxwell-McCaw & Zea, 2011).

Given the significant associations between cultural identity and well-being outcomes, it is important to understand the factors that influence cultural identity development. Several school and communication variables have been identified as predictors of cultural identity development, including the language used (Bat-Chava, 2000; Kobosko & Zalewska, 2011), the type of school placement and hearing status of classmates (Hadjikakou & Nikolarazi, 2007; Hardy, 2010; Israelite, Ower, & Goldstein, 2002; Oliva, 2004; Schwartz et al., 2007; van Gorp, 2001), and the use of devices (Leigh, Maxwell-McCaw, Bat-Chava, & Christiansen, 2009; Most, Wiesel, & Blitzer, 2007). The influence of these variables is significant, and research is well-established and underway to identify and understand the protective and risk factors associated with these variables. This dissertation focuses on the role that parents play in cultural identity development and well-being.

Parental Socialization, Cultural Identity, and Well-Being

Culture is typically passed down from generation to generation within the context of a culturally homogenous family through socialization. *Socialization* is the process by which parents transmit their worldview to their children and teach them about the beliefs, values, and behaviors they believe their children will need as they become adults (Chakawa & Hoglund, 2016). Two aspects of socialization are particularly relevant to transmitting culture to children of minoritized groups: cultural socialization and racial socialization. *Cultural socialization*, involves exposure to and promoting cultural customs, values, and traditions to facilitate internalization of the norms and expectations of the family culture (Lee, 2003). *Racial socialization* involves transmitting messages related to living in a diverse and stratified society, such as promoting awareness of and means of coping with discrimination (Hughes & Chen, 1997).

Socialization messages can be transmitted to children in different ways, or via different modes of transmission, such as direct verbal instruction and conversations intended to teach the child about culture and minority status, and nonverbal messages, such as parents modeling cultural involvement and practices or managing the child's cultural environment, experiences, and opportunities (Lesane-Brown, 2006; Paasch-Anderson, Lamborn, & Azen, 2019).

Deaf culture may not be transmitted in the typical, intergenerational manner because approximately 96% of deaf and hard of hearing children are born to hearing parents who do not identify with the Deaf culture (Mitchell & Karchmer, 2004). The present literature review did not find any empirical studies on parental socialization practices regarding Deaf culture. This dissertation addresses this gap in the literature by exploring the role parents play in transmitting Deaf culture and how such socialization predicts the cultural identity development and well-being of emerging adults who are deaf or hard of hearing.

Ethnic-racial socialization and identity. To begin to understand the role parents may play in Deaf cultural identity development, a review of the literature on the role of parents in ethnic-racial identity development (i.e., ethnic-racial socialization) is presented. Deaf cultural identity and ethnic-racial identity are both cultural identities; they reflect social identities based on membership in a cultural group. Therefore, the role of parents as agents of socialization in ethnic-racial identity development that is well-established empirically may generalize to other cultural groups, such as the Deaf cultural group.

Ethnic-racial socialization (which includes cultural socialization and racial socialization) is the intergenerational transmission of messages to younger generations regarding the importance of ethnic-racial group membership (i.e., cultural socialization) and the consequences

of group membership in a society with ethnic-racial social inequalities (i.e., racial socialization; Hughes et al., 2006).

Parental engagement in ethnic-racial socialization predicts ethnic-racial identity development and well-being in families that belong to ethnic-racial minority groups (Hughes et al., 2006; Neblett, Smalls, Ford, Nguyễn, & Sellers, 2009). Ethnic-racial socialization promotes aspects of ethnic-racial identity development, such as ethnic identity centrality, positive feelings toward ethnic-racial group, and sense of connectedness to ethnic-racial group (Rivas-Drake, Hughes, & Way, 2009), as well as well-being outcomes, such as self-esteem (Constantine & Blackmon, 2002), personal growth (Basow, Lilley, Bookwala, & McGillicuddy-Delisi, 2008), and academic success (Neblett, Philip, Cogburn, & Sellers, 2006).

Unshared cultural socialization and ethnic-racial identity. There is a caveat to applying the ethnic-racial socialization framework to the deaf and hard of hearing population: Most parents of deaf and hard of hearing children are themselves hearing. They may have had little or no experience with Deaf culture prior to having their child. Therefore, they are not in the same position as ethnic-racial minority parents who are passing on their own family culture to their children.

An example of the socialization of an unshared culture exists within the transracial adoption literature. When majority group member parents adopt children from different ethnic, racial, national, cultural, or linguistic backgrounds, they may strive to promote identity development regarding a culture that may be foreign to them by engaging in unshared cultural socialization of the child's birth culture (Lee, Grotevant, Hellerstedt, & Gunnar, 2006). They do so by having cultural toys, books, and artifacts in the home, attending cultural events, and facilitating relationships with individuals from the child's birth culture (Bailey, 2006).

As with shared ethnic-racial cultural socialization, adoptive parents' unshared cultural socialization promotes the child's ethnic-racial identity development (Basow et al., 2008; DeBerry, Scarr, & Weinberg, 1996) and subsequent positive psychosocial outcomes, such as fewer externalizing behaviors (Johnston, Swim, Saltsman, Deater-Deckard, & Petrill, 2007).

Deaf cultural socialization. The primary objective of this dissertation is to address the gap in the literature and explore the role that parents play in well-being and cultural identity development of their deaf and hard of hearing children. To do so, the ethnic-racial socialization framework is applied to a deaf and hard of hearing sample of emerging adults to see if the associations between socialization and outcomes generalize to the Deaf cultural community.

This dissertation introduces two new constructs of socialization that are specific to the deaf and hard of hearing populations: Deaf cultural socialization and minority status socialization. *Deaf cultural socialization* is defined as the process by which parents transmit messages to children regarding the importance and meaning of Deaf culture and membership in the Deaf community, such as modeling participation in Deaf cultural events. *Minority status socialization* is defined as the process by which parents transmit messages to children regarding how to be successful as a deaf person in a hearing environment, such as talking to their children about discrimination they may face as a result of being deaf.

Two new psychometric scales were developed to measure the extent to which emerging adults report that their parents socialized them regarding the Deaf culture (i.e., the Deaf Cultural Socialization Scale; DCSS) and regarding their minority status based on their hearing loss (i.e., the Minority-Status Socialization Scale; MSS). The ethnic-racial socialization literature demonstrates that socialization predicts cultural identity development and well-being. To evaluate if the ethnic-racial socialization literature can be applied to Deaf culture, this

dissertation explores the associations between these new measures of Deaf-specific socialization (i.e., DCSS and MSS) and psychosocial outcome variables including cultural identity, self-esteem, satisfaction with life, and depression and anxiety.

The second objective of this dissertation is to challenge an assumption found in the Deaf identity literature (Bat-Chava, 2000; Glickman & Carey, 1993; Ohna, 2004; Weinberg & Sterritt, 1986) that suggests that parents' hearing status shapes cultural identity development and well-being.

Parents' Hearing Status, Cultural Identity, and Well-Being

The Deaf identity literature generally assumes that cultural identity development in deaf and hard of hearing individuals is largely determined by parents' hearing status, such that hearing parents raise culturally Hearing children and deaf parents raise culturally Deaf children (Bat-Chava, 2000; Chen, 2014; Glickman & Carey, 1993; Maxwell-McCaw, Leigh, & Marcus, 2000). This assumption is not baseless. The literature review will present empirical evidence of group differences based on parents' hearing status that seem to support this assumption, as well as some authors' theoretical explanations for why these group differences might exist. In short, those with deaf parents have been found to have more preferable cultural identity and psychosocial outcomes than those with hearing parents (Bat-Chava, 1993; Maxwell-McCaw, 2001; Meadow, 2005). For example, a meta-analysis found self-esteem is higher for those with deaf parents (Bat-Chava, 1993).

Glickman and colleagues (Glickman, 1993, 1996; Glickman & Carey, 1993) outlined the significance of parents' hearing status in their stage theory of Deaf identity developmental. The theory posits that deaf and hard of hearing children with hearing parents will have Marginal or

Hearing identities. This is based on the assumption that children either adopt their family's culture (Hearing identity) or the lack of access to a full, shared language with their family will result in poor social skills that impair their ability to fit-in with both Hearing and Deaf communities (Marginal identity). Conversely, those with deaf parents are presumed to initially develop Deaf or Bicultural identities. This is based on the assumption that children either adopt their family's culture (Deaf identity) or that their parents' modeling of how to successfully interact within hearing contexts can promote comfort with and appreciation of both groups (Bicultural identity; Glickman, 1993; Glickman & Carey, 1993; Glickman, 1996).

This dissertation aims to challenge this assumption that parents' hearing status determines child outcomes. These different developmental trajectories seem extreme and deterministic. The focus on parents' hearing status underestimates the active and intentional role parents might play. This dissertation suggests that parental engagement in socialization may explain the group differences in outcomes that have been found based on parents' hearing status. Parents, whether they are deaf or hearing, may engage in socialization practices to differing degrees. Some deaf parents may not choose to engage in Deaf-specific socialization, while some hearing parents may choose to do so. This difference in degree of socialization may be a better predictor of cultural identity development and well-being than parents' hearing status.

Shifting the discussion from a biologically determined, passive, unchangeable characteristic (i.e., parents' hearing status) to active, intentional parenting practices (i.e., socialization) could have significant implications. It may enable and reinforce parents' efforts to adopt these beneficial behaviors. Additionally, these results could influence professionals who work with deaf and hard of hearing youth to inform, educate, and support these families and their efforts to support cultural identity development and the associated psychological well-being.

Significance of the Problem

Deaf and hard of hearing individuals present with a variety of cultural identities. These cultural identities are associated with distinct psychosocial outcomes. It is therefore important to understand factors that predict healthier outcomes in order to promote that trajectory. While parental engagement in socialization practices is well-established as a significant factor in cultural identity development for members of ethnic-racially minoritized groups, this has not yet been explored within the Deaf cultural community.

Group differences based on parents' hearing status have been found in cultural identity and well-being outcomes for deaf and hard of hearing individuals. These group differences are important to understand, because studies have found that those with deaf parents (which is relatively rare, approximately 4% of the deaf population) have healthier cultural identity and psychosocial outcomes than those with hearing parents (Bat-Chava, 1993; Maxwell-McCaw, 2001; Meadow, 2005). However, by focusing on parents' unchangeable, biologically determined hearing status and the associated group differences, the existing research misses the opportunity to identify specific parenting behaviors that are associated with positive outcomes. An identification of specific protective parenting behaviors would enable informed parents and professionals working with deaf and hard of hearing children and adolescents to adopt the beneficial behaviors, regardless of their hearing status.

Problem statement. There is a gap in the Deaf identity literature regarding the role of parents as agents of socialization. The existing literature on cultural identity development focuses on a passive, unchangeable characteristic (i.e., parents' hearing status), rather than on active, adoptable, intentional, and protective behaviors (i.e., socialization practices).

The primary objective of this dissertation is to explore parents' socialization practices as a mechanism through which parents influence their child's cultural identity development and well-being by applying the ethnic-racial socialization framework. To do so, the constructs of Deaf cultural socialization and minority status socialization are introduced, and the associated measures have been developed to capture emerging adults' retrospective reports of their parents' socialization practices. The degree of engagement in socialization is expected to be associated with cultural identity and psychosocial outcomes.

The second objective of this dissertation is to challenge the assumption that cultural identity and well-being outcomes are determined by parents' hearing status. Parental engagement in Deaf cultural socialization and minority status socialization are expected to vary among parents, regardless of their hearing status. Parents, whether they are deaf or hearing, likely engage in socialization practices to differing degrees. It is here expected that degree of socialization will be a better predictor of cultural identity development and well-being than parents' hearing status.

The study uses a cross-sectional survey design with an online sample of deaf and hard of hearing emerging adults to answer the following research question: How is parental engagement in socialization related to being deaf (i.e., Deaf cultural socialization and minority status socialization) associated with cultural identity development and well-being outcomes (i.e., self-esteem satisfaction with life, and depression/anxiety) in a sample of deaf or hard of hearing emerging adults?

Chapter 2

Literature Review

This dissertation explores the role of parents as agents of socialization regarding Deaf culture and the association between such socialization and subsequent well-being and cultural identity development. This literature review begins by establishing social identity theory as a theoretical foundation. A brief summary of American Deaf Culture and Deaf cultural identity is then presented to orient the reader contextually. Next, an assumption found in the Deaf identity literature regarding the role of parents in Deaf cultural identity development (i.e., the parents' hearing status hypothesis) is presented and debated. An alternative explanation of the role parents play is then proffered (i.e. the socialization hypothesis). A review of literature regarding the role of parents in other types of cultural identity development (i.e., ethnic-racial socialization) is then presented and used as a framework to support the development of the socialization hypothesis in Deaf cultural identity development.

Theoretical Foundation: Social Identity Theory

This dissertation is built upon the foundation of social identity theory (Tajfel, 1981). Social identity theory tells us that individuals are members of many social groups and that membership in these groups contributes to how they see themselves. The consequence of social group memberships is *social identity*, or the part of the self-concept based on group membership and the value and significance attached to group membership. The degree and nature of the influence of group membership may depend on several variables, such as the salience of group membership, the individual's sense of belonging in the group, society's valuation of the group, and the individual's valuation of the group (H Tajfel, 1981).

Social identity theory (H Tajfel, 1981) suggests that people tend to seek out groups or remain in groups that make positive contributions to their social identity, such as groups that instill pride or prestige. Social identities involve social comparison and categorization processes, as individuals see in-group members as being similar to themselves. There is a natural human tendency to evaluate an in-group positively. This motive for self-enhancement creates positive feelings and raises one's self-worth. And when individuals feel accepted, recognized, and valued by other in-group members, their social identity is verified and they develop a sense of belonging (Burke & Stets, 2009).

Identifying as a member of a social group can be protective, even if the social group is marginalized. Many minoritized groups are held in low esteem by the majority society. When a social group is marginalized or stigmatized by the majority society, members may seek to distance themselves from the group, socially and psychologically, and strive to "pass" as a member of the majority group. Alternatively, they may choose to reinterpret the group's characteristics, embrace the group's distinctiveness, and develop pride in the minority group. Doing so can be protective due to a sense of belonging and shared experiences (H Tajfel, 1981).

Parents likely play a large role in shaping their child's social identity development. They may influence the social groups that are salient to the child by what they say to the child and the experiences to which they expose the child. The valence of parents' comments about social groups, negative or positive, may transmit the value of the social group to the child. Parents may model which social groups they belong to as a family. This dissertation explores how this type of parental behaviors and messages may predict the internalization of a social identity based on membership in Deaf culture.

Deaf Culture

Minoritized groups are often defined by the majority group. This is done with an ethnocentric view of the minoritized group as being different from the “norm” of the majority (Tajfel, 1981). This is true of the deaf minority group, which the majority society has historically viewed through the medical model. The medical model (a.k.a. infirmity, impairment, disability, or pathological model) sees deaf individuals as disabled. It focuses on a physical deviance, a pathology, which is to be ameliorated with medical treatment and interventions, such as cochlear implants and speech and auditory training, to make deaf individuals as “hearing” as possible (Holcomb, 2013; Lane, 1999; Lane, Hoffmeister, & Bahan, 1996; Leigh, 2009).

The Deaf community has tended to reject this conceptualization of a disabled group needing to be “normalized” or “fixed” to be more like the hearing majority. During the past 50 years, the Deaf community has spurred a paradigm shift from the medical model to the cultural model (a.k.a. sociolinguistic, social-minority or language minority model) which views hearing loss as a difference, or human variation, which creates a cultural minority group with a shared language, traditions, values, behavioral patterns, and social norms (Holcomb, 2013; Leigh, 2009).

American Deaf culture (referring specifically to the United States) is unique from other Deaf cultures around the world because of the historical context that has shaped its development. American Deaf culture traces its roots to 1816, when a teacher of the deaf from France was invited to come and help establish the first school for the Deaf in America (Padden & Humphries, 1988). Since then, schools for the Deaf have served a crucial role in developing and maintaining a culture and a language that has been passed down through generations of deaf students (Holcomb, 2013; Lane, 1999; Lane et al., 1996; Padden & Humphries, 1988).

Deaf clubs in most major cities also provided an important foundation of American Deaf culture by giving deaf people a place to congregate for entertainment, social, political, and service purposes. Deaf clubs were cherished for the opportunities they provided for contact and communication with peers. Many customs and behavioral patterns were born of the Deaf clubs. For example, leave-taking is a very lengthy process in the Deaf community. Historically, it could have been a very long time before contact could be made again, via letter or the next Deaf Club event, so separation was never taken lightly (Holcomb, 2013; Lane, 1999; Lane et al., 1996; Padden & Humphries, 1988).

American Deaf culture has its own system of values. The Deaf community is collectivistic, and community members exchange mutual help. Information sharing is valued, as they may not have access to incidental information that hearing people might overhear throughout the day. As a result, it is common in the American Deaf culture to disclose personal information, discuss matters such as money, health, hygiene, and solutions to life's challenges. Self-determination is valued. The Deaf community engages in political activism toward shared goals and common interests and has established various agencies to advocate for deaf people (Holcomb, 2013; Lane, 1999; Lane et al., 1996; Padden & Humphries, 1988).

American Deaf culture has a rich history of arts and entertainment. While storytelling in ASL is most cherished and prolific, there are also works of literature, such as poetry, humor, and written accounts of culturally archetypal stories of overcoming oppression and being saved by ASL and the Deaf community. Visual artists tend to use their arts to create Deaf awareness, often incorporating Deaf themes or the manual alphabet in their works. Theatres for the Deaf have flourished for decades. Deaf athletic organizations have thrived and been a source of pride and shared experience (Holcomb, 2013; Lane et al., 1996; Padden & Humphries, 1988).

The most visible, important, and distinctive aspect of American Deaf culture is American Sign Language (ASL). ASL is a full and natural language that uses hand shapes, movement, location, orientation, body language, facial expression and more to communicate the phonology, morphology, syntax, and discourse of any manner of idea (Leigh et al., 2016). The value of ASL underscores all aspects of American Deaf culture, from the significance of the schools for learning ASL (through instruction and/or from peers), the clubs for facilitating communication in ASL, political activism advocating for the right to ASL, and the arts expression of ASL.

These aspects of American Deaf culture create a sense of belonging. They represent shared experiences, a communal history, and inherited ways of thinking, being, and problem solving passed down by previous generations of deaf people. Deaf culture provides an opportunity to find connections and communalities, which can be very attractive to people who may have grown up isolated, perhaps never having met another deaf person (Holcomb, 2013; Padden & Humphries, 2009). Deaf culture also provides access to cultural capital, such as social connections and aspirational role models that may promote resilience (Listman, Rogers, & Hauser, 2011).

In the past 20 years, the traditional foundations of the American Deaf culture have decreased in prevalence. As of the 2010 Annual Survey of Deaf and Hard of Hearing Children and Youth (Gallaudet Research Institute, 2011) that reported on 37,828 deaf and hard of hearing students in the United States (not inclusive), only 24% of deaf and hard of hearing students attend a Deaf School. Younger generations do not utilize Deaf clubs like the previous generations did. With the advent of closed captioning, entertainment in the form of television and movies is available from the comfort of most homes. Technological advances such as the internet, text messaging, and video chatting make it possible for deaf people to communicate at

any time with both deaf and hearing people (Holcomb, 2013; Lane et al., 1996; Leigh et al., 2016).

Despite these evolutions, Deaf community members remain passionately invested in their culture. The underlying value of the Deaf schools and the Deaf clubs was the comfortable exchange of shared experiences and ideas with a common visual language, and this need for community is still being met within the modern landscape of the Deaf community (Scheetz, 2004). But without the traditional means of culture transmission via Deaf schools and Deaf clubs, parents may play a more important role in Deaf cultural identity development now than ever before.

Deaf Cultural Identity

This study explores precursors of *Deaf cultural identity*, or Deaf identity, which is a social identity based on membership in the Deaf cultural group. Deaf cultural identity has been described as follows:

Those individuals who identify themselves as culturally Deaf are individuals who use ASL or a signed language, who feel strongly that being Deaf is a benefit or a gain, socialize with other culturally Deaf persons, and live a visual way of life. They feel at home with each other (Leigh, Andrews, & Harris, 2016; p. 161).

Models of understanding the cultural identity of those who are deaf and hard of hearing have been proposed based on two frameworks that are extensions of social identity theory: ethnic-racial identity development and immigrant acculturation. Both models are bicultural and dynamic in nature, reflecting an ongoing process of negotiating a minoritized status within the context of the majority culture over time. The two models are presented here to review the

literature and to situate the subsequent debate regarding the role of parents in Deaf cultural identity development.

Ethnic-Racial Identity Development Framework

The first model of Deaf cultural identity was influenced by the ethnic-racial identity development framework, which focuses on a component of one's social identity based on membership in an ethnic or racial group.

Race and *ethnicity* are often defined, conceptualized, and measured with distinct theories and measurement tools and applied to different collective groups. For example, a study group on race, culture, and ethnicity (Murry, Smith, & Hill, 2001) defined *race* as “phenotypic differences that arise from genetic or biological dispositions, such as skin color and hair texture,” while they defined *ethnicity* as “perceived group membership based on nationality, ancestry, or both” (p. 913). The study group pointed out that authors tend to use the term *race* when referring to African Americans and *ethnicity* when referring to Latinos. The two terms are not interchangeable, though, as that would imply that “behaviors can be understood based on physical characteristics (common criteria for defining race) rather than as a function of socialization, experience, and the environment (common criteria for defining ethnicity)” (Murry et al., 2001). However, the study group also clarified that categorizing people based on race or ethnicity to describe group differences in behaviors ultimately reflects “an assumed, underlying, latent construct that affects behaviors and child developmental outcomes. This underlying latent construct is culture... The role of culture as a way of life that a group of people- who may or may not have a common ethnicity- share and transmit from one generation to another provides a window into the underlying mechanisms that are manifested as ethnic or racial differences”

(Murry, Smith, & Hill, 2001; p. 912). In this way, ethnic and racial identities are essentially cultural identities.

Rivas-Drake et al. (2014) made the argument that there is significant overlap across ethnic and racial theories and measures of identity, as well as limited evidence of ethnic or racial group differences in their application. They suggest that the distinct racial and ethnic frameworks reflect researcher preferences and traditions, rather than a meaningful difference in the constructs of racial identity and ethnic identity. Therefore, the hybrid term, *ethnic-racial*, is adopted in this dissertation when referring to characteristics based on ethnic and/or racial group membership, such as identity.

Ethnic-racial identity is a multidimensional construct that involves self-identification as a member of an ethnic-racial group, positive group attitudes, sense of belonging, and cultural involvement (Marcia, 1966; Phinney, 1990; Phinney & Ong, 2007; Rivas-Drake et al., 2014).

Various stage theories have been proposed to describe the formation of ethnic-racial identity (Cross, 1991; Leigh, 2009; Phinney, 1996; Sue & Sue, 1999; Vandiver, Fhagen-Smith, & Cokley, 2001). Phinney (1989) proposed a three-stage progression based on the commonalities of these models. In the first stage, a young individual from a minoritized group has an unexamined ethnic-racial identity. Ethnicity/race may not be salient to them. They often adopt the dominant society's views of their group. They may internalize negative stereotypes and show preference for the White majority culture. Commonly during adolescence, there is a period of search and exploration. Experiences such as discrimination, exposure to diversity, or discovery of positive ethnic-racial role models can cause dissonance and challenge the previously held beliefs. Ethnicity/race is highly salient during this time. During this stage, people often have very positive attitudes toward their ethnic-racial group, anger toward the

majority group, and empathy for other oppressed groups. Individuals may reject the dominant culture and enthusiastically embrace the minority culture. In the third stage, the individual develops a deeper understanding of and accepts aspects of both cultures and can adapt their cultural behaviors to what is appropriate for a particular context. They hold more realistic attitudes about the positive and negative attributes of their ethnic-racial group and the majority and can function comfortably in either context in a bicultural manner. The progression through these stages may not be linear or consistent across contexts.

The American Deaf cultural community has been described as an ethnic group, or an ethnicity. An *ethnicity* is “an ascribed or self-identified affiliation typically based on aspects of one’s family heritage, shared language, culture, or marginality” (Wakefield & Hudley, 2007; p. 148). Ladd and Lane (2013) argue that the American Deaf cultural community is an ethnic group because it has a shared language (ASL), a sense of belonging (e.g., easy communication, solidarity, collective action), a distinct culture (e.g., rules for behavior based on distinctive values), art, history, institutions (e.g., Deaf schools, Deaf clubs, Deaf organizations, performance and athletic organizations), kinship, a code of conduct (e.g., for maintaining boundaries from the hearing majority), and a typical method of socializing deaf children (i.e., by way of unrelated deaf adults).

Ethnic-racial identity and Deaf identity share key components, such as self-identification as a group member, sense of belonging and attachment to one’s group, pride and positive feelings towards one’s group, and behavioral involvement including social participation and culturally-specific practices (Ladd & Lane, 2013; Phinney, 1992). As is common with marginalized ethnic-racial minority groups, the Deaf community has experienced a long history of oppression, marginalization and political and economic disadvantages within the hearing-

dominated American society, ranging from language oppression and employment discrimination to social pressures discouraging their intermarriage and reproduction (for a full discussion of the oppression of the Deaf culture see Lane, 1999; Glickman, 1996). Individuals from groups that are minoritized based on ethnicity/race or hearing status must make sense of what membership in a marginalized group means for their sense of self (H Tajfel, 1981).

Based on these commonalities, the underlying construct of cultural identity, and the conceptualization of American Deaf culture as an ethnicity, the framework of ethnic-racial identity development has been applied to the study of Deaf cultural identity development.

Deaf Identity: The Developmental Model

Glickman (1993) presented a developmental model of Deaf identity that used the ethnic-racial identity framework to describe how deaf and hard of hearing individuals go through a process of understanding and internalizing their membership in a marginalized group similar to individuals from other minoritized groups. The Deaf identity developmental model suggests that individuals progress through stages toward healthier identity statuses.

Initially, deaf children from hearing families would begin identifying as either culturally Hearing or Marginal, depending on if they are late-deafened or pre-lingually deaf and how successfully they are engaging in the family culture. Those with a *Hearing identity* are primarily late-deafened, or those who lose their hearing after establishing a Hearing identity. Those with Hearing identities adopt the dominant, Hearing society as their reference point for normalcy and health. They view being deaf as an abnormality or disability. The Hearing world and oral/aural communication are valued while being deaf is minimized or resented. Those with a *Marginal identity* do not fit-in with the Hearing or Deaf cultures. Glickman suggests that the

communication barrier inherent with being deaf in a hearing home interferes with the acquisition of values and mores of the Hearing culture, which can lead to socially undesirable behaviors which can alienate others. Failure to connect with hearing others and lack of access to deaf others leads to failure to belong anywhere (Glickman, 1993, 1996; Glickman & Carey, 1993).

Deaf-Immersion identity is a stage that involves a positive and uncritical identification with Deaf people. ASL is viewed as superior to English. Hearing values are rejected and the Hearing majority is considered oppressive and malevolent. The Deaf-identified may discourage others from acting in “hearing-identified” ways, like using their voices, using hearing aids/cochlear implants, or using signed English (which is grammatically different than ASL; Glickman, 1993, 1996).

In the last stage, *Bicultural identity*, individuals find comfort in both cultures and are skilled in negotiating cultural differences. They feel Deaf pride but are still comfortable with hearing people. They can oppose the discrimination of deaf people without opposing hearing people (Glickman, 1993, 1996). Glickman suggested that deaf children raised in Deaf families usually begin with bicultural identities because ASL and deaf culture are the norm and parents model how to interact with Hearing society.

The model asserts that the earlier stages (i.e., Marginal and Hearing identities) are not as healthy as the end stage (i.e., Bicultural identity). Some authors have questioned this linear progression through stages, suggesting that one does not need to go through the earlier stages to be bicultural, nor do they need to reach the end stage to be healthy (Leigh et al., 2009; Maxwell-McCaw & Zea, 2011). For example, some individuals with cochlear implants may function successfully in the Hearing world with minimal constraints, with low salience of hearing loss, no

internalization of negative stereotypes, strong communications skills, and meaningful relationships. Contact with Deaf culture may not lead to an immersion phase if encounters are negative due to language barriers and cultural incompetence, leaving the individual feeling rejected or alienated. Authors (e.g., Leigh, Marcus, Dobosh, & Allen, 1998; Maxwell-McCaw, 2001) have also challenged the stereotypical views of the distinct identity statuses which ignore the diversity of the population and the implied in-group and out-group biases. Not all with Deaf-Immersion identities are resentful toward the Hearing majority, nor are all Hearing-identified individuals self-hating. Due to these challenges, the developmental model conceptualization and the associated measure of Deaf identity have not been applied empirically as often as the second model of Deaf cultural identity based on the immigrant acculturation framework.

Immigrant Acculturation Framework

The second model used to understand Deaf cultural identity development is the immigrant acculturation framework. Berry (1997) explains that acculturation broadly deals with cultural changes at the group- or individual-level that result from ongoing contact with two distinct cultures. At the individual level, psychological acculturation is a cultural identity process that involves psychological and behavioral changes that occur when an individual migrates and encounters a new culture and the degree to which an immigrant individual maintains identification and participation with their original culture and the degree to which they adopt identification and participation with the new culture. Authors suggest that acculturation is multidimensional, including aspects of behavior, knowledge, values, cultural identity, and language proficiency (Berry, 1997; Schwartz et al., 2013; Zea, Asner-Self, Birman, & Buki, 2003).

The orientations to the distinct cultures are considered bilinear and independent from each other; one cultural orientation does not threaten the other (Phinney, 1990; Schwartz, Unger, Zamboanga, & Szapocznik, 2010). The degree to which the original culture is maintained and the degree to which the new culture is adopted can be combined to form four acculturation strategies or statuses: assimilation, separation, integration, and marginalization. *Assimilation* strategy adopts the new culture and sheds the culture of origin. *Separation* strategy maintains the culture of origin and does not adopt the new culture. *Integration* strategy maintains the culture of origin while at the same time adopting the new culture. *Marginalization* strategy neither maintains the culture of origin, nor adopts the new culture (Ward, 2008).

Deaf Identity: The Acculturation Model

Maxwell-McCaw (2001) adopted the bilinear, multidimensional acculturation model to understand Deaf cultural identity development, drawing parallels between balancing membership in a minoritized culture and a majority culture. Unlike immigrants, however, deaf individuals tend to be raised in the majority culture (i.e., in a Hearing home) and later may adopt some degree of orientation to the minoritized culture (i.e., Deaf culture).

Maxwell-McCaw (2001) combines the behaviors, attitudes, cultural competence, and the degree of psychological identification associated with each culture (Deaf and Hearing) into the individual's two cultural orientations (a.k.a., Deaf acculturation and Hearing acculturation). The degree of orientation to the two cultures can be combined to create four cultural identity statuses (a.k.a. acculturation statuses): Hearing, Deaf, Marginal, and Bicultural. *Hearing* identity involves high orientation toward Hearing culture only. *Deaf* identity involves high orientation toward Deaf culture only. *Bicultural* identity involves high orientation toward both cultures. *Marginal* identity involves lack of high orientation toward either culture.

The associated measure, the Deaf Acculturation Scale (DAS; Maxwell-McCaw & Zea, 2011), was developed based on the Abbreviated Multidimensional Acculturation Scale (Zea et al., 2003) from immigrant acculturation research. The DAS has two culture scales, one measuring orientation toward the Hearing culture, and one measuring orientation toward the Deaf culture. Each cultural scale has five subscales that assess cultural identification, cultural involvement, cultural preferences, cultural competence, and language competence. Marschark, Zettler, and Dammeyer (2017) clarify that multiple administrations of the Deaf Acculturation Scale would measure the *process* of acculturation, as acculturation denotes behavioral and attitudinal change over time due to ongoing contact with two cultures. They suggest that a single administration of the DAS measures current cultural identity status.

The Significance of Cultural Identities

Social identity theory suggests that developing an identity based on membership in a social group (e.g., cultural identity) can be beneficial, even if the group is low-status or oppressed (H Tajfel, 1981). Group membership provides an individual with a sense of belonging and shared experience that buffers the effects of discrimination (Neblett et al., 2008b; Rivas-Drake et al., 2009). Empirical research supports this theoretical assertion of cultural identity being beneficial.

Ethnic-racial identity and outcomes. Developing a cultural identity based on ethnic or racial group membership is associated with positive outcomes. Studies have found that ethnic-racial identity is associated with higher self-concept, self-esteem, psychological adjustment, bicultural self-efficacy, life satisfaction, positive attitudes toward and relations with members of other groups, and ethnic-racial identity development protects against the effects of negative stereotypes and discrimination (David, Okazaki, & Saw, 2009; Phinney, 1989, 1990; Phinney &

Chavira, 1995; Phinney & Devich-Navarro, 1997; Phinney, Jacoby, & Silva, 2007; Umaña-Taylor, Yazedjian, & Bámaca-Gómez, 2004; Yap, Settles, & Pratt-Hyatt, 2011).

Immigrant acculturation and outcomes. Studies of immigrant acculturation have found that acculturation is associated with divergent outcomes, as well. Acculturation is associated with stress response, adaptation, and the type and efficacy of coping strategies used by immigrants (Kuo, 2014). A meta-analysis (Yoon et al., 2013) of 325 studies found that acculturation was associated with mental health outcomes. Specifically, marginalization was associated with the most negative mental health outcomes (e.g., higher in depression, anxiety, and negative affect), while integration was associated the most positive mental health (e.g., higher self-esteem, satisfaction with life, and positive affect).

Deaf identity development model and outcomes. Cultural identity based on membership in Deaf culture is also beneficial. Research using the Deaf identity development model, (typically using the associated measure, the Deaf Identity Development Scale; DIDS; Glickman & Carey, 1993) has found Marginal identity to be associated with the most unhealthy outcomes, such as low self-concept (Cornell & Lyness, 2004) and interpreting the world as hostile and bad natured (Gordon, 1998). As the stage model would suggest, Bicultural identity predicts the healthiest outcomes, such as high levels of self-concept (Cornell & Lyness, 2004). Both Deaf-Immersion and Bicultural identities tend to predict positive psychosocial outcomes, such as better academic placement and social relationship satisfaction (Weinberg & Sterritt, 1986) and higher self-esteem (Bat-Chava, 2000), indicating that identifying with Deaf culture is adaptive for deaf individuals.

Deaf acculturation model and outcomes. Research based on the Deaf acculturation model uses the Deaf Acculturation Scale (DAS; Maxwell-McCaw & Zea, 2011). Both the

degree of Deaf acculturation and the degree of Hearing acculturation have been found to be significantly correlated with satisfaction with life, overall well-being, optimism, and personal resources (Hintermair, 2008; Maxwell-McCaw, 2001). Analyzing the four cultural identity statuses for group differences, Deaf and Bicultural identities have been associated with higher overall well-being, satisfaction with life, and self-esteem than those with high Hearing or Marginal identities (Hintermair, 2008; Maxwell-McCaw, 2001). This suggests that some degree of acculturation in the Deaf community and culture facilitates psychological well-being, regardless of degree of acculturation with the Hearing culture (Leigh et al., 2009).

Using both the Deaf identity development and the Deaf acculturation model, Bicultural identification is consistently associated with the most positive outcomes (e.g., Bat-Chava, 2000; Glickman & Carey, 1993) The ability to integrate and comfortably access two cultures and communities seems to involve adaptability and flexibility that enables healthy functioning. Marginal identification is consistently found to be associated with the least healthy outcomes (e.g., Chapman & Dammeyer, 2017). Failure to identify with either cultural group may reflect the inability to communicate meaningfully with significant others due to language barriers. Language barriers may prevent implicit learning of norms that may leads to behavior disorders, poor social skills, egocentricity, immaturity, and insensitivity to the needs of others (Glickman & Carey, 1993). However, Hintermair (2008) found that those with a Marginal identity who reported high levels of personal resources (defined as self-control, personal agency, and optimism), did not have negative psychosocial outcomes.

In line with the ethnic-racial identity and immigrant acculturation frameworks, both Deaf identity development and Deaf acculturation models demonstrate the importance of cultural identity development. Given the range of psychosocial outcomes associated with developing

these distinct identities, it is important to understand the factors that relate to Deaf identity formation for deaf and hard of hearing individuals. The discussion now turns to the role of parents in cultural identity development.

Two Explanations of the Role of Parents in Deaf Cultural Identity Development

This section debates two alternative explanations for how parents might shape their deaf and hard of hearing child's well-being and cultural identity development: the parents' hearing status hypothesis and the socialization hypothesis. The former is reflected in the writings of some authors on Deaf identity, while the latter is suggested by this author as an alternative explanation.

Parents' hearing status hypothesis. While never referred to as "the parents' hearing status hypothesis," there is an assumption alluded to in the Deaf identity literature regarding the influence of parents' hearing status on cultural identity development. Authors have suggested, subtly and overtly, that parents' hearing status determines cultural identity outcomes (e.g., hearing parents raise culturally Hearing children and deaf parent raise culturally Deaf children; Bat-Chava, 2000; Glickman & Carey, 1993; Ohna, 2004; Weinberg & Sterritt, 1986). This section will review the theoretical and empirical basis of this hypothesis, before presenting contradictory evidence that challenges the parents' hearing status hypothesis.

Deaf identity development stage theories suggest that children with hearing parents will have Marginal or Hearing identities, at least until they are exposed to the Deaf community later in life (Glickman & Carey, 1993; Holcomb, 1997; Ohna, 2004). For example, Glickman (1996) suggest that the majority of deaf children with hearing parents will grow up in a state of identity confusion and cultural marginality marked by poor communication skills, inappropriate social

behavior, relationship difficulties, inability to fit-in, and ambivalence toward both Hearing and Deaf communities. This cultural marginality represents a lack of a personal identity. The individual would form his or her first true identity during a subsequent phase of immersion into Deaf culture, which the author referred to as “emerging out of a culturally and linguistically confused wasteland” (p. 139) which may not occur until college- or adult-age discovery of the Deaf community. This paints a bleak picture for the 96% of deaf children with hearing parents.

Deaf children with deaf parents are presumed to initially develop Deaf or Bicultural identities, marked by a cultural view of being deaf (rather than a medical/pathological view of being deaf), a connection with other Deaf people, and an understanding of the strengths and weaknesses of both Deaf and Hearing groups. Being raised in a home where being deaf and using sign language are the norm allows for the development of cultural pride, while their parents’ modeling of how to successfully interact with hearing environments promotes comfort with and appreciation of both groups (Glickman, 1996). This presumes more preferable outcomes for those with deaf parents.

Supporting this hypothesis of disparate developmental trajectories, research has found group differences in cultural identity outcomes between groups of deaf individuals with hearing parents versus those with deaf parents. Those with deaf parents score higher on the Deaf/Immersion Identity scale of the measure associated with the Deaf identity developmental model (i.e., the Deaf Identity Development Scale; Glickman, 1993). Using the Deaf acculturation model and associated scale (the Deaf Acculturation Scale), Maxwell-McCaw & Zea (2011) reported that those with deaf parents scored higher than those raised in hearing homes on all of the Deaf culture subscales: cultural identification, cultural involvement, cultural preferences, cultural competence, and language competence; those with hearing parents scored

higher on each of the parallel Hearing cultural subscales, except for Hearing cultural competence, for which there was no group difference. In Maxwell-McCaw's (2001) impressively large sample of over 3,000 deaf individuals (mean age=37.5), a small proportion of the sample had Hearing (8%) or Marginal (1%) cultural identities. The majority of those with Hearing and Marginal identities had hearing parents (92.5% and 88.9%, respectively).

Authors have proffered explanations regarding why parents' hearing status might predict cultural identity outcomes. Bat-Chava (2000) suggested that hearing parents are influenced by medical and educational professionals who tend to view being deaf as a disability (i.e., the medical model of being deaf), and they transmit those messages to their child, thereby discouraging a cultural view of being deaf that might foster Deaf cultural identity development. Holcomb (1997) suggests that hearing parents focus on spoken English and functioning in the hearing world to the detriment of developing Deaf cultural competence.

These explanations regarding sources of influence, model of being deaf, and communication preferences have been supported empirically. The recommendations of professionals have been reported as the most important factor for parents in deciding on a language modality for deaf children (Hardonk et al., 2010; Li, Bain, & Steinberg, 2003). Decker et al. (2012) found that parents who receive information and influence from medically related professionals, such as audiologist and speech pathologist, are more likely to have a medical view of being deaf. Parents who adopt the medical view of being deaf are more likely to choose a spoken language upbringing for their deaf child, which emphasizes speech and hearing abilities; those who adopt a cultural view of being deaf are more likely to incorporate sign language (Decker et al., 2012; Duncan, 2009; Hardonk et al., 2010; Hyde et al., 2010). Use of American Sign Language (ASL) is a crucial element of Deaf culture in the United States and a defining

characteristic of conceptualizations of a Deaf identity. Using sign language in the home predicts Deaf and Bicultural identities, while using spoken language only predicts Hearing and Marginal cultural identities (Bat-Chava, 2000; Maxwell-McCaw, 2001).

Maxwell-McCaw & Zea (2011) suggest that Deaf identity development does not typically begin until school age or much later, when deaf children from hearing families might first meet Deaf role models. Meadows (1972) suggested three primary opportunities to be socialized into the Deaf community during the typical life cycle: birth, enrollment in school, and graduation from high school. Those born into culturally Deaf families are socialized from birth within the family. Those who are enrolled in schools for the deaf are socialized in school by native signers and Deaf role models. Those who have not been exposed to Deaf culture by graduation from high school may seek out sign language and the Deaf community as they become independent adults outside of their family home. Some will never join the Deaf cultural community. Holcomb (2013) referred to these three potential periods of socialization as opportunities to be “delivered from linguistic impoverishment and cultural void” (p. 87).

More recently, Padden and Humphries (2009) agreed that many do not join the Deaf cultural community until they reach adulthood and their “parents relinquish control” (p. 151). Small sample studies and anecdotal accounts have also suggested that Deaf identity development commonly advances during the college experience (Holcomb, 1997; McIlroy & Storbeck, 2011; Wolsey, Clark, van der Mark, & Suggs, 2017).

Multiple explanations from authors were reviewed regarding why parents’ hearing status predicts cultural identity outcomes. However, the explanations reviewed were not actually related to parents’ biologically determined hearing status, per se, but rather to their sources of influence and information, their model of being deaf, their preferences for spoken language over

signed, and their child's access to the Deaf community. While these explanations are reasonable and supported empirically, the hearing status hypothesis problematically implies that all hearing parents (and all deaf parents) are alike. This ignores the diversity in preferences, experiences, motivations and specific parenting practices of both deaf and hearing parents. Some deaf parents do not sign and are not members of the Deaf cultural community. Not all hearing parents raise their child in a "culturally and linguistically confused wasteland" (Glickman, 1996; p. 139). Both deaf and hearing parents could ascribe to the cultural model of being deaf, value sign language, and engage in the Deaf community. These attitudes and behaviors, rather than the parents' hearing status, would likely predict distinct outcomes.

The underlying assumption of the parents' hearing status hypothesis is that hearing parents cannot or do not socialize their child regarding the Deaf culture; only members of the Deaf community can do so. Meadows (1972) clarified that "family of orientation is rarely the agent of socialization. Hearing status, rather than family status is the crucial variable in the identity of the initial agent of socialization to this linguistic community" (p. 24). And Lane (1999) said of a deaf child with hearing parents, this is his "crucial problem: He has to learn to be cultural deaf from other people- and that despite his parents" (p. 160).

To imply that the context of the hearing family cannot provide exposure and opportunity for Deaf cultural identity development seems to overgeneralize, underestimate, and stereotype parents. With the help of cultural brokers, language models, and mentors from the Deaf community, hearing parents likely are able to support Deaf cultural identity development in meaningful ways. Evidence will now be presented that challenges this hypothesis by demonstrating that it underestimates hearing parents and ignores variability among both deaf and hearing parents.

Contradictory evidence. Not all hearing parents are the same; nor all deaf parents. Holcomb (1997) proposed a stage model of bicultural Deaf identity development that describes a common experience of a long, difficult journey toward positive cultural identities in adulthood. He lamented that many deaf children do not have a full common language with their family members that would allow for meaningful connections and feelings of acceptance, nor do they have Deaf role models to look up to. He suggests that their process of cultural identity development can be painful and fraught with feelings of isolation as a result.

In the final paragraph of Holcomb's (1997) article, he points out that a small number of deaf college students whom he interviewed reported that they did not have the common difficult journeys described throughout the article. These individuals reported that they had hearing parents who embraced the Deaf culture early in their lives and made sure they had access to the Deaf community while growing up. This early exposure shaped their understanding of themselves and their expectations and interactions with members of both Deaf and hearing groups in positive ways. This small group challenges the assumption that parents' hearing status predicts outcomes, as there may be variability in parenting behaviors and environmental factors that influence cultural identity development.

Similarly, Padden and Humphries (2009) described several paths into the Deaf community. Some are born into it within Deaf families. Some find it in adulthood when they meet other deaf people, either by accident or by design. And some, they explained, "had hearing parents who signed and encouraged their deaf children's association with other Deaf people, easing their acquisition of the language and knowledge of the community" (p. 151). This again suggests variability in parenting behaviors among hearing parents that likely influence cultural identity development.

The book, *Far from the Tree: Parents, Children, and the Search for Identity* (Solomon, 2012), explores several situations in which children develop identities they do not share with their parents, including stories of children who are deaf, dwarfs, transgender, prodigies, and more. These situations are considered horizontal identities, because they do not involve the vertical transmission of a culture from parents, but rather the children must find a culture of peers on their own. Solomon included the stories of several families of deaf children that reflected a wide array of experiences. He interviewed hearing parents who became activists for Deaf culture and fluent signers. He also interviewed hearing parents who fought against their deaf child learning to sign for fear they would lose their child to the Deaf culture. He also interviewed a variety of deaf parents, some of who embraced a spoken language upbringing for their deaf children, and others who immersed their child in the Deaf community. These anecdotal cases reflect a wide variety of parenting preferences, motivations, and socialization practices that challenge the view of universal, predictable patterns based on parents' hearing status.

In an interview study with hearing parents of deaf children, Husting (2018) found some instances of support for the parents' hearing status hypothesis (i.e., that hearing parents raise culturally Hearing children). For example, one mother of two deaf children said, "To us, they put the hearing aid in and they're hearing... They're hearing kids. I don't think a diagnosis is an identity" (p.18). However, some parents said things that challenged the hearing status hypothesis, such as,

I would like for her to be able to communicate with people who are fully deaf, with the Deaf community. I want her to feel as comfortable with the Deaf culture as she is with the Hearing culture, because she's going to be in both whether she wants to or not. She's

going to have one foot in each one... By embracing her deafness, by embracing knowing about the Deaf culture and knowing there's this whole other side of people, that she could be a part of, it gives her one more option. One more tool in that kit (p. 55).

As this comment highlights, some hearing parents perceived a bicultural identity as adaptive and desirable for their child. This attitude would likely motivate different parenting behaviors than the participant who made the preceding comment.

The hearing mothers also varied in their engagement in cultural socialization practices that likely support cultural identity development. Specifically, these parents varied in their efforts to expose their child to Deaf culture, such as seeking Deaf peers and mentors, and in the exposing the child to ASL. One family who relocated to live near and have their child attend a Deaf school did so because,

We wanted her to be around other deaf kids... We wanted her to know Deaf culture and have other Deaf people in her world. Because she got the gene from us, but we have no idea what it is like (Husting, 2018; p. 24).

This higher degree of exposure to the Deaf culture and Deaf community while growing up will likely foster aspects of Deaf cultural identity development, such as cultural competence and psychological identification as a member of the Deaf community.

This contradictory evidence, which provides the foundation for the present investigation, suggests that parents' hearing status may not be the best predictor of Deaf cultural identity development, given the diversity that exists within parent hearing status groups. These anecdotes and small sample studies essentially identify variation in parents' engagement in socialization. As an alternative to focusing on parents' hearing status, this dissertation suggests

socialization as a developmental mechanism that promotes and predicts cultural identity development and well-being outcomes, such as self-esteem, satisfaction with life, and mental health. The nature of parental socialization regarding Deaf culture has not been thoroughly explored theoretically or empirically.

A review of ethnic-racial socialization research is now presented to serve as a framework with which to subsequently construct a conceptualization and measure of socialization regarding Deaf culture.

The socialization hypothesis: Deaf cultural socialization. As an alternative to focusing on parents' hearing status, this author suggests socialization as a developmental mechanism that promotes and predicts Deaf cultural identity development and well-being.

Parents and the immediate family are the first social institution and primary context for the child's identity exploration (Erikson, 1964). Parents can play a large role in shaping their child's cultural context and subsequent cultural identity development through socialization. *Socialization* is the process by which parents transmit their worldview to their children and teach them about the beliefs, values, and behaviors they believe their children will need as they become adults (Chakawa & Hoglund, 2016). Parents teach children about the meaning, significance, attitudes, and behaviors associated with the various components of social identity they expect the child to develop in order to help the children function as adults and negotiate their particular society (Wang, Benner, & Kim, 2015; Zayas & Solari, 1994). While other forces act as socializing agents, such as the extended family, peers, neighborhood, school, and the media, parents play the primary role in shaping their children's social identities (Erikson, 1964) through parental socialization practices and are, therefore, the focus of this discussion.

There is presently a gap in the literature regarding the nature of socialization regarding Deaf culture and its relationship with cultural identity and psychosocial outcomes. Therefore, the ethnic-racial socialization framework was used to construct a conceptualization of socialization regarding Deaf cultural identity development.

Ethnic-Racial Minority Families: Transmitting a Shared Culture

Ethnic-racial socialization is defined as the intergenerational, vertical transmission of messages to children regarding the importance and meaning of their ethnic-racial group membership (Hughes et al., 2006). This includes strategies parents use to negotiate cultural experiences within the family and extent to which they promote the child's ethnic identity development (Lee et al., 2006). Parents' serve as agents of ethnic-racial socialization by modeling in-group behavior, educating children regarding appropriate rules and norms of the culture, promoting routines and habits associated with social customs and cultural practices, exposing the child to members of the cultural group, and facilitating the child's participation in culture-relevant activities. These practices instill a firm sense of social identity, teaching the child "who we are and what we do" (Grusec & Davidov, 2010; p. 699).

Most parents engage in ethnic-racial socialization (Hughes, 2003; Hughes et al., 2006; Neblett et al., 2009), particularly parents from minoritized groups who may do so to protect the child from the negative effects of discrimination (Else-Quest & Morse, 2015). Ethnic-racial socialization benefits youths, particularly minoritized youths, by enhancing their sense of belonging, group esteem, and teaching coping tools to offset the stresses associated with minority status (Liu & Lau, 2013). Teaching minoritized children to embrace their cultural roots is also protective and adaptive because it prepares children to thrive in their community by

developing the values, beliefs, and behaviors consistent with their group (Chakawa & Hoglund, 2016).

Socialization messages vary in their content, or theme. Several authors have attempted to identify multiple facets of ethnic-racial socialization, which typically include messages transmitting knowledge of and pride in the ethnic culture (i.e., cultural socialization) and messages preparing the child for facing discrimination in an ethnic-racially stratified society (e.g., racial socialization, preparation for bias; Brown & Krishnakumar, 2007; Hughes & Chen, 1997; Lesane-Brown, Scottham, Nyugen, & Sellers, 2005; Umaña-Taylor & Fine, 2004). For example, Hughes and Chen (1997) distinguished between three themes: cultural socialization, preparation for bias, and promotion of mistrust. *Cultural socialization* messages transmit cultural knowledge, values, and practices. *Preparation for bias* messages involve warning children of racism and discrimination, as well as teaching children coping skills to deal with these. *Promotion of mistrust* messages convey the need for wariness and distrust when dealing with members of other (primarily dominant) ethnic-racial groups.

Some authors have used the terms ethnic socialization and racial socialization interchangeably or as a hybrid construct: ethnic-racial socialization (Rivas-Drake et al., 2014). Other authors have identified a distinction between ethnic socialization and racial socialization. For example, Brown and Krishnakumar (2007) differentiated between messages related to the social meanings of race (i.e., racial socialization) and the passing on of culture (i.e., ethnic socialization). They used *racial socialization* to describe the explicit messages parents transmit to their child about racial barrier awareness, how to cope with racism and discrimination, and promoting cross-racial relationships. They used *ethnic socialization* to describe parents' explicit

and implicit messages related to cultural values, cultural embeddedness, cultural heritage and history, and promotion of ethnic pride (Brown & Krishnakumar, 2007).

In addition to distinctions in the content of messages (*what* messages are transmitted), there are different ways of transmitting messages (*how* messages are transmitted), called modes of transmission. *Modes of transmission* refers to how messages are transmitted to children in relation to their *expression* and their *intent* (Lesane-Brown, 2006).

The expression of messages can be verbal or nonverbal. Verbal messages are explicit and can be direct, such as conversations the parent has with the child about culture or directives they give to him/her regarding culturally appropriate behavior. Verbal messages can also be indirect, such as when the child observes conversations the parent has with others (Lesane-Brown, 2006). Nonverbal messages include modeling cultural behaviors (e.g., cooking ethnic food, celebrating cultural holidays), structuring the child's environment (e.g., having cultural art and books in the home), and selectively reinforcing cultural behaviors (Lesane-Brown, 2006). Yasui (2015) adds that nonverbal expression can include automatic responses (e.g., spontaneous affective, verbal, and nonverbal reactions beyond the parents' consciousness).

The intent of messages, or their purpose or the state of mind of the agent of socialization, can be *deliberate* or *inadvertent*. Deliberate messages are purposely given to the child, such as when a parent takes their child to a cultural museum with the intention of educating them on their heritage or discusses means of coping with discrimination with the intent of equipping the child with the skills to handle experiences effectively (Lesane-Brown, 2006). Socialization messages may also be transmitted inadvertently (spontaneously, automatically), or without deliberate intention. This occurs the child subtly receives messages regarding race, ethnicity, or

culture by observing their parents' interactions with others, their affective reactions that may be out of the parent's control and awareness (Lesane-Brown, 2006; Yasui, 2015).

These three facets of socialization (i.e., the content of the messages and the expression and intent of transmitting them) may interact. For example, racial socialization messages tend to be verbal and deliberate, as parents discuss experiences they have had with racism and discrimination with the intention of equipping their child with coping skills. Cultural socialization messages tend to include inadvertent nonverbal messages, such as parents modeling participation in the cultural celebrations that are traditional within the family (Paasch-Anderson et al., 2019). Pertinent to the present operationalization of socialization, Umaña-Taylor and Fine (2004) presented a model of adolescent ethnic identity development that included ecological factors of the family's micro (i.e., characteristics of the family, school, and community) and macro environments (i.e., ethnic/race relations in the society, SES) that influenced the family's engagement in ethnic socialization behaviors, which in turn influenced ethnic identity development. They delineated between overt and covert socialization messages. Overt messages are purposeful and directly attempting to teach the child about the ethnic group. Covert messages may not be intended as socialization, but nevertheless transmit messages about ethnicity inadvertently through daily life, such as selection of ethnically related home decorations and everyday activities.

Parents engage in socialization for different reasons. Motivations might include the desire to prepare their child for social challenges associated with their ethnicity/race's position in society, to pass on traditions, to ensure the child's success in mainstream settings, and/or to foster pride and group affiliation (Chakawa & Hoglund, 2016; Hughes, 2003; Langrehr, 2014; Rollins & Hunter, 2013). Parental practice of ethnic-racial socialization is a positive child

rearing strategy that is related to, but distinct from, other forms of positive parenting and parental involvement (Chakawa & Hoglund, 2016).

Parents have been found to engage in a variety of socialization practices, varying in frequency and content of messages. Some parents may focus on positive and proactive messages, such as promoting ethnic pride or self-worth. Others may focus on more reactive messages, such as racial barrier messages in response to discrimination experiences (Hughes et al., 2006; Neblett, Philip, Cogburn, & Sellers, 2006).

Socialization is a bidirectional process in that frequency and content of parental socialization may change based on child characteristics and experiences. Socialization practices vary developmentally, as children mature physically, cognitively, and socio-emotionally and race, ethnicity, and social comparisons become more salient to them (Phinney & Chavira, 1995; Rivas-Drake et al., 2009). While parents of young children may focus on cultural socialization, by adolescence, parents are more likely to include messages about promotion of mistrust and preparation for bias, as the adolescents become increasingly aware of and experience racism, discrimination, and diversity in their lives and society in general (Hughes & Chen, 1997). By adolescence, cognitive skills advance to allow for abstract thinking and social perspective-taking. Adolescents are better able to integrate their experiences and are more aware of the experiences of others. They become more aware of the role ethnicity/race plays in their lives and how society views them (Neblett et al., 2008; Quintana & Vera, 1999; Rivas-Drake et al., 2009).

While most parents engage in socialization about the meaning of race, a small percentage of parents report little or no engagement. This silence transmits its own messages to the child about the significance of race, without providing tools for coping with discrimination (Caughy, Nettles, & Lima, 2011; Hughes et al., 2006; Rollins & Hunter, 2013). Lack of

socialization could reflect communication problems within the family. Parents' ethnic-racial socialization messages relate to how salient ethnicity/race is to the parent, which may vary based on the socialization messages they themselves received as children (Hughes & Chen, 1997), their own experiences with discrimination and their ethnic-racial identity (Hughes, 2003). Parental engagement in ethnic-racial socialization is also related to demographic characteristics such as parent's gender (mothers engage in more socialization; Brown & Krishnakumar, 2007), age (older parents engage in more socialization; Hughes & Chen, 1997), marital status (married parents engage in more socialization; Csizmadia, Rollins, & Kaneakua, 2014), education (more education, more socialization; Neblett et al., 2009), and socioeconomic status (higher status careers and higher income relate to more frequent socialization; Csizmadia, Rollins, & Kaneakua, 2014). Other contextual factors related to parents' racial socialization practices include their geographic region (less socialization in the Southern U.S.; Csizmadia et al., 2014) and urbanicity (more socialization in urban areas, compared to small, rural towns; Csizmadia et al., 2014). These factors relate to the parents' worldview. They also structure the opportunities and resources available for children, the values and attitudes to which they are exposed, and the amount of diversity and discrimination they experience (Neblett et al., 2008).

Ethnic-racial socialization and ethnic-racial identity. According to social identity theory, identification is more likely to occur with those groups that are valued, and a positive ethnic identity is best facilitated by exposure to information and experiences that communicate the inherent value of the particular ethnic group (Tajfel, 1981). If socialization messages are positive, the children's evaluation of their ethnic identity and of their own personal worth and feelings of competence will tend to be positive.

Empirically, ethnic-racial socialization has been found to relate to several aspects of ethnic identity. High rates of positive ethnic-racial socialization messages (e.g., cultural socialization and messages of self-worth) are positively associated with ethnic identity centrality, exploration and resolution of ethnic-racial identity, positive feelings toward ethnic-racial group, and sense of connectedness to ethnic-racial group, which are all components of ethnic-racial identity (Phinney, 1990; Rivas-Drake et al., 2009; Umaña-Taylor et al., 2004a).

Ethnic-racial socialization relates to other outcomes (Hughes et al., 2006; Neblett et al., 2009). Positive messages (such as cultural socialization, self-worth, and racial pride) are consistently associated with positive child outcomes, such as self-esteem (Constantine & Blackmon, 2002; Umaña-Taylor et al., 2004a) and academic success (Neblett, Philip, Cogburn, & Sellers, 2006). Messages that prepare the child for discrimination (such as preparation for bias, promotion of mistrust, or racial barrier messages) are associated with mixed results, generally indicating that a moderate level is beneficial and protective, while too few messages leave a child unprepared for discrimination and too many messages may make children hypervigilant to perceive discrimination, which leads to more anxiety and depression (Liu & Lau, 2013; Neblett et al., 2008).

The effect of ethnic-racial socialization on well-being outcomes may be mediated by ethnic-racial identity development (e.g., Neblett, Banks, Cooper, & Smalls-Glover, 2013; Rivas-Drake, 2011). Ethnic-racial socialization promotes ethnic identity development, which in turn relates to many psychosocial outcomes, conceptually and empirically (Hughes et al., 2006; Rivas-Drake, 2011). Ethnic-racial socialization messages that promote racial pride, sense of belonging and attachment to group members create positive feelings and attitudes about the ethnic-racial group, which are associated with positive child outcomes, such as increased self-

esteem (Constantine & Blackmon, 2002; Umaña-Taylor et al., 2004a) and decreases in depressive symptoms and perceived stress (Neblett, Banks, Cooper, & Smalls-Glover, 2013).

This exploration of socialization has so far focused on parents transmitting their own culture to their children. However, approximately 96% of deaf and hard of hearing children have hearing parents. Therefore, the next section introduces socialization of an *unshared* culture.

Transracially Adoptive Families: Transmitting an Unshared Culture

Parents engage in cultural socialization even when they themselves do not belong to the cultural group. An example of this can be found with transracial adoptive families, in which parents have adopted children from different racial, ethnic, cultural, or national backgrounds. These parents face the challenges of socializing and fostering identity development regarding an unshared culture; a culture with which they may not be very familiar initially. These parents may be in the position of teaching children about discrimination and what it means to be a member of a minoritized group, when they themselves may not be minoritized (Samuels, 2009).

Despite these challenges, many transracially adoptive parents engage in cultural socialization to foster development of the unshared cultural identity (Friedlander, Larney, & Skau, 2000; Samuels, 2009). They may do so by having cultural toys, books, and artifacts in the home, attending cultural events, learning about the culture's traditions and history, attempting to learn the child's native language, and facilitating relationships with children and adults from the child's birth country or background (Bailey, 2006). These socialization practices promote and predict the child's cultural identity development (Basow, Lilley, Bookwala, & McGillicuddy-Delisi, 2008; DeBerry, Scarr, & Weinberg, 1996) and positive psychosocial outcomes, such as fewer externalizing behaviors (Johnston et al., 2007) and higher scores on personal growth and self-acceptance (Basow et al., 2008).

Recent research indicates that most transracially adoptive parents provide intentional cultural socialization to foster birth-culture identity development (Friedlander et al., 2000); but not all do. Some adoptive parents choose alternative strategies, such as waiting for the child to express an interest in their birth culture or taking a color-blind approach, minimizing or denying differences (Lee et al., 2006). Adoptive parents who express colorblind attitudes provide less cultural socialization, and rate the child's pride, identification, and awareness of their ethnic-racial group as less important than parents who do not express colorblind beliefs (DeBerry et al., 1996; Langrehr, 2014; Lee et al., 2006). These attitudes, in turn, predict fewer socialization practices and less ethnic pride in adoptees (Langrehr, 2014). Samuels (2009) suggests that parents with colorblind attitudes fail to see the world through the child's eyes or help them understand racial power dynamics.

In order for these parents of ethnically, racially, or culturally different children to successfully engage in cultural socialization, they need to develop *cultural competence*, or the knowledge, attitude and skills suited to helping their child develop a positive ethnic-racial identity, sense of belonging with their birth culture, and the ability to cope with racism (Bailey, 2006; Massatti, Vonk, & Gregoire, 2004; Vonk, 2001). Authors suggest that adoptive parents may need cultural competence assessment, education and training, and connections with cultural brokers or mentors from the birth culture, based on the assumption that the parent cannot teach a culture they do not know (Bailey, 2006; Manzi, 2014; Massatti et al., 2004; Vonk, 2001).

International laws indicate that internationally adopted children have a right to their ethnic-racial identity and to be educated about their cultural background (United Nations, 1989). Social service professionals recommend that adoptive parents be educated, assessed, and supported in the understanding of the child's birth culture and the importance of cultural identity

development (Bailey, 2006). No such laws or social service recommendations are in place for hearing parents of deaf and hard of hearing children.

In summary, parents play an important role in their child's ethnic-racial identity development and well-being through ethnic-racial socialization, regardless of whether the culture is shared or unshared. Applying this understanding to families with deaf and hard of hearing children, parental socialization behaviors and messages may be an underlying mechanism driving divergent cultural identity and well-being outcomes in the deaf population.

Deaf Cultural Socialization

Ultimately, two conceptualizations of socialization related to being deaf (i.e., Deaf cultural socialization and minority status socialization) were developed for this study. Using the definition of ethnic-racial socialization as a model, this author defines *Deaf cultural socialization* as the process by which parents transmit messages to children regarding the importance and meaning of Deaf culture and membership in the Deaf community. *Minority Status Socialization* is defined as the process by which parents transmit messages about discrimination and how to cope with or overcome such difficulties associated with being minoritized (i.e., being deaf).

Some underlying assumptions guided the development of these constructs. First, it is assumed that developing a Deaf cultural identity is beneficial. This assumption is supported by the literature review presented above that demonstrated the association between positive psychosocial outcomes and Deaf cultural identity development (e.g., Maxwell-McCaw, 2001). Secondly, it is assumed that parents' hearing status is not ultimately deterministic of psychosocial outcomes. Those with deaf parents are not guaranteed certain outcomes (e.g., a Deaf identity and high self-esteem), while those with hearing parents are guaranteed other

outcomes, based solely on parents' hearing status. Variability in parenting practices and in child outcomes are expected among both those with deaf parents and those with hearing parents (Padden & Humphries, 2009; Solomon, 2012; Husting, 2018). Thirdly, it is assumed that parents can play a role in cultural socialization, even if they do not share the culture with the child. This assumption is based on the transracial adoption literature (e.g., Johnston et al., 2007), as well as the evidence presented above regarding hearing parents who promote Deaf cultural identity development (e.g., Husting, 2018; Holcomb, 1997). However, this is not to imply that hearing parents can do so without the help and support of mentors and other cultural brokers from the Deaf cultural community.

Approximately 4% of deaf children have at least one deaf parent (Mitchell & Karchmer, 2004). While understudied empirically, parents in these rare multigenerational Deaf families might presumably transmit the Deaf culture to their children via socialization practices similar to parents of other minoritized groups, such as families ethnic-rationally minoritized groups. Leigh, Andrew, and Harris (2016) suggested that those whose who are deaf and from culturally Deaf homes will naturally absorb the family's culture and develop a Deaf identity. This "absorption" may be fostered by parents passing on the socialization messages they received as children, and surrounding the child with Deaf community members, a shared culture, and a common language. A measure of Deaf cultural socialization practices would allow for exploration of culture transmission in these relatively rare multigenerational deaf families. A measure of minority status socialization might identify how these parents pass on their own experiences coping with being deaf in Hearing society.

The majority of deaf individuals grow up in culturally Hearing homes, with parents who may have had little or no contact with the Deaf community or culture. For them, Leigh, Andrew,

and Harris (2016) suggested that identity development depends on their experiences, such as how their parents talk about being deaf, their language development, and the quantity and quality of their social and cultural exposures to the Deaf culture and community. Specifically, “if interactions with other deaf persons are a positive experience, and if the family is supportive of encouraging the child to be comfortable as a deaf child, it becomes easier for that child to feel a strong sense of deaf identity” (p. 162). This does not suggest that cultural identity is determined by the parents’ hearing status, but rather, cultural identity of those from hearing families depends on what the family does and says to encourage the child’s comfort with being deaf and the experiences they have with the Deaf cultural community. This demonstrates the role of socialization in cultural identity development.

Lane (1999) essentially described what hearing parents’ engagement in Deaf cultural socialization could look like when he lamented about a set of hearing parents, “If only they had made their home bilingual, accepting their son was a member of a language minority. If only they had come to know some members of the deaf community, studied their language, observed how they conducted their lives, listened to their counsel and not to that of the audists. If only they had seen to it that their son was taught in his most fluent language. If only they had tried, as Sammy grew into the deaf community, to grow with him” (p. 161).

Historically, the primary means of transmitting the Deaf culture to younger generations of deaf children was via “surrogate parents” (non-family members from the Deaf community; Ladd & Lane, 2013) who acted as agents of cultural socialization later in the child’s life. Deaf peers and mentors at schools for the Deaf passed on language and cultural knowledge, and Deaf clubs fostered a sense of community (Holcomb, 2013; Lane, 1999; Lane et al., 1996; Padden & Humphries, 1988). Padden and Humphries (2009) wrote that most people come to the Deaf

community not through family, but through contact with other Deaf people at school. Referring to one of the authors, they said that though he had grown up with profound hearing loss, he “was not Deaf until he learned to be” in college (p. 160).

These historical modes of cultural transmission are no longer the norm due to societal changes discussed in the preceding section on Deaf culture. Despite the decline in the prevalence of Deaf school and Deaf club attendance, many Deaf individuals still gravitate toward the Deaf community and culture and develop Deaf cultural identities (e.g., Maxwell-McCaw & Zea, 2011). This leads to the question: How do deaf individuals cultivate Deaf cultural identities in the modern landscape? Given the decline of the traditional modes of culture transmission, the role of parents as agents of cultural socialization becomes more significant.

This dissertation suggests that socialization predicts cultural identity development. This shifts the focus to parenting practices, rather than on the biologically determined, unchangeable characteristic of hearing status. The two hypotheses are not mutually exclusive, and this author does not deny the likelihood of group differences based on parents’ hearing status. The socialization hypothesis aims to *explain* the group differences found based on parents’ hearing status, while shifting the focus from a static characteristic to adaptive and adoptable behaviors.

Deaf parents might be assumed to engage in more Deaf cultural socialization, as they are vertically passing down their own culture. The value of sign language will be naturally conveyed in a home of signers. Deaf parents are far more likely to be engaged with the Deaf community. Deaf parents likely have more knowledge about the culture and history to pass on, as well as lived experiences with discrimination and bias. A child being raised in this environment will likely develop a sense of belonging to the Deaf community and culture.

Hearing parents might be assumed to engage less in Deaf cultural socialization, reflecting their lack of knowledge and experience with Deaf culture and its history. Hearing parents may have had little contact with the Deaf community prior to having a deaf child. They likely do not know ASL, and learning a new language, particularly one that is not spoken, is a very daunting and time-consuming feat. Even if motivated to engage in Deaf cultural socialization, hearing parents may face barriers. They likely face language and cultural barriers. The Deaf community can be rejecting of hearing parents at times, especially if the parents and child are not learning ASL (Hardin, Blanchard, Kemmery, Appenzeller, & Parker, 2014; Husting, 2018). Families that live in smaller communities may not have access to the Deaf community or resources intended to support hearing families with deaf children (Husting, 2018).

However, technology and the multicultural nature of modern society may be reducing the impact of some of these barriers. The internet allows parents to connect with their peers (other hearing parents of deaf children), Deaf organizations, and scores of information about the Deaf culture. There are many free opportunities for parents to learn ASL through Deaf schools, online programs, and video series. Some states have summer camps for deaf children, allowing the children to build connections they may not have access to in their neighborhoods, and modern technology allows them to maintain those relationships. Now, more than ever before, hearing parents have options and resources to support their culturally sensitive parenting.

While Deaf cultural socialization has been understudied, there has been research indirectly assessing aspects of socialization by examining the decisions parents make that shape the child's experiences and environments. The decision-making literature indicates that deaf parent and hearing parent groups differ in their initial decisions regarding amplification devices, language modality, and school setting for the young child. Those with deaf parents are more

likely to use sign language, attend a school for the Deaf, and less likely to have a cochlear implant; those with hearing parents are more likely to receive cochlear implants, use spoken English, and attend a mainstream school (Bat-Chava, 2000; Decker et al., 2012; Duncan, 2009; Eleweke & Rodda, 2000; Hardonk et al., 2010; Hyde et al., 2010; Kluwin & Stewart, 2000; Leigh, Maxwell-McCaw, Bat-Chava, & Christiansen, 2009; Li et al., 2003; Maxwell-McCaw & Zea, 2011; Mitchell & Karchmer, 2004a; Wright, 1987). The language used (Bat-Chava, 2000; Kobosko & Zalewska, 2011), the type of school placement and hearing status of classmates (Hadjikakou & Nikolarazi, 2007; Hardy, 2010; Israelite et al., 2002; Oliva, 2004; Schwartz et al., 2007; van Gorp, 2001), and the use of amplification device (Leigh et al., 2009; Most et al., 2007) have all been found to be variables that predict distinct cultural identity outcomes.

These decisions reflect cultural socialization in the form of the environments and communication context parents select for their child and the value messages these decisions transmit to children about preferences regarding language modality, peers, and the Deaf community. Thus, rather than operating directly and deterministically as implied by the hearing status hypothesis, parents' hearing status more likely has an indirect impact on cultural identity development by influencing decisions made about school setting, amplification devices, and language modality; which in turn influence cultural identity development (Decker et al., 2012; Hyde et al., 2010; Leigh et al., 2009).

Research on the role of parents in their child's Deaf cultural identity development has rarely gone beyond ascertaining parent's hearing status and these decisions made early in the child's life. Additional research is needed to understand the impact of the parents' socialization messages and behaviors throughout childhood that continue to shape the child's environments, experiences, and perspective on what it means to be deaf. Previous research has focused on

group differences between hearing and deaf parents, assuming homogeneity of these parent groups. A measure of Deaf cultural socialization practices would provide better understanding of the variation of practices that may be found, not just between, but *within* these parent groups.

Implying that all hearing parents are alike, and all deaf parents are alike stereotypes parents and underestimates their motivation and ability to engage selectively in culturally sensitive parenting. Given the multicultural nature of modern society and the diversity of parents' experiences, beliefs, and motivations, it is likely that some hearing parents may choose to support Deaf cultural identity development and some deaf parents may not choose to do so, perhaps preferring to support Hearing cultural identity development. Parental engagement in socialization practices and subsequent cultural and psychosocial outcomes will likely vary among these hypothetical parents, though these assumptions need to be evaluated empirically.

A measure of socialization was needed to explore the nature of parental engagement in socialization and to assess how these parenting practices are associated with outcomes. Such a measure would enable a deeper understanding of how the relatively rare intergenerational Deaf families transmit their shared culture and experiences to their deaf children. It would also allow for exploration of the transmission of an unshared culture in hearing families. The transracial adoption literature demonstrates that parents can engage in unshared cultural socialization, and that doing so predicts cultural identity development and positive psychosocial outcomes. To ascertain if these associations generalize to the transmission of the Deaf culture, a measure had to be developed.

Constructs of Interest in the Current Study

This dissertation sought to explore parental engagement in socialization regarding the Deaf culture as an independent variable predicting indicators of cultural identity and well-being, while controlling for potentially confounding variables. To do so, there was a clear need for a measure of Deaf cultural socialization to enable empirical research. This dissertation involved the development and application of such a measure. The measures of the socialization developed herein are the primary independent variables in the present investigation. The dependent variables include cultural identity, self-esteem, satisfaction with life, and depression/anxiety. Control variables include parents' hearing status, relationship with parents, and sociodemographic characteristics. This section briefly provides the rationale for the chosen variables.

Socialization. Deaf cultural socialization was originally conceptualized as a single latent construct with three subscales (i.e., verbal, nonverbal, and minority status socialization), but during the preliminary examination of the data, the decision was made to divide subscales into two separate constructs (Deaf cultural socialization [verbal and nonverbal expression modalities] and minority status socialization; see Construction of the Scales in the next chapter for further discussion).

Building on the ethnic-racial socialization framework (Brown & Krishnakumar, 2007; Grusec & Davidov, 2010a; Hughes & Chen, 1997), socialization regarding Deaf culture is likely multifaceted, including verbal and nonverbal messages and behaviors across multiple domains that convey to the child the importance, significance, and centrality of being deaf and a member of the Deaf cultural community. Two facets of socialization are explored here: Deaf cultural socialization and minority status socialization. Again, *Deaf cultural socialization* is defined as the process by which parents transmit messages to children regarding the importance and

meaning of Deaf culture and membership in the Deaf community. *Minority Status Socialization* is defined as the process by which parents transmit messages about discrimination and how to cope with or overcome such difficulties associated with being minoritized (i.e., based on hearing status). These facets of socialization are measured using the Deaf Cultural Socialization Scale and the Minority Status Socialization Scale, respectively.

This dissertation introduces, develops, measures, and explores the utility of these two new constructs of socialization and the associated measures in predicting psychosocial outcomes of a sample of deaf and hard of hearing emerging adults.

Cultural identity. The primary outcome variable of interest is cultural identity development. The Deaf acculturation model was selected for this study because it is the most accepted in the literature (Maxwell-McCaw et al., 2000). It is preferred because it provides a multidimensional approach that accommodates differing degrees of orientation to the Deaf and Hearing cultures, independently, while not assuming out-group or in-group attitudes or implying stereotypic views of the identity statuses, as the alternative conceptualization, the Deaf identity development model does (Glickman, 1993). The measure associated with the Deaf acculturation model, the Deaf Acculturation Scale (DAS; Maxwell-McCaw & Zea, 2011), is the most widely used measure of cultural identity in the Deaf identity research (e.g., Hintermair, 2008; Marschark et al., 2017). The DAS assesses Deaf and Hearing acculturation, separately, and categorizes distinct cultural identity statuses.

The ethnic-racial socialization literature uses ethnic-racial identity development rather than acculturation, as an outcome variable. Ethnic-racial identity and immigrant acculturation are distinct constructs and processes, with the former focused on psychological affiliation and attitudes and the latter focusing on behavioral components of biculturalism. However, the

established association between socialization and identity is expected to generalize to this deaf and hard of hearing sample using the acculturation model. Deaf identity research uses the acculturation model as a conceptualization of cultural identity. Marschark, Zettler, and Dammeyer (2017) clarified that multiple administrations of the DAS would measure the *process* of acculturation, as acculturation denotes behavioral and attitudinal change over time due to ongoing contact with two cultures. They suggest that a single administration of the DAS measures current cultural identity status.

Self-esteem. It was once believed that membership in a minoritized group would have a negative impact on an individual's self-esteem due to internalization of the majority society's negative attitudes about the minoritized group. However, Rosenberg (1986) indicates that the majority of research has not supported this. He suggested that children who are members of minoritized ethnic groups grow up in families and communities of fellow ethnic group members and therefore may not be aware of or accept the majority's negative attitudes. Additionally, the people who are most significant to the child may hold positive in-group attitudes and be positive examples of the in-group for the child to look up to. In this way, group membership can buffer the effects of negative attitudes. This shared cultural environment is not the norm for deaf children, however, who are mostly raised in hearing homes. Still, positive socialization messages that tell the child that Deaf culture is salient and positive may make group membership seem more advantageous, and therefore more likely to contribute positively to their sense of self-worth.

Self-esteem has been studied extensively with the deaf population, particularly with regard to parents' hearing status. A meta-analysis of 12 studies found that those with deaf parents had higher self-esteem than those with hearing parents (Bat-Chava, 1993). As with

children from other minoritized groups, growing up in a Deaf home and Deaf community may reduce the awareness and acceptance of the majority society's negative attitudes, as well as provide positive attitudes and role model examples that will buffer the effects of negative attitudes. Supporting this, Maxwell-McCaw (2001) found higher self-esteem associated with greater orientation to Deaf culture, as measured by the Deaf Acculturation Scale. Deaf children growing up in hearing homes may be at greater risk of internalizing negative attitudes that will lower self-esteem.

The focus on parents' hearing status again presents the overgeneralization and implication of homogeneity within parent groups being made by the hearing status hypothesis. Deaf parents can have children with low self-esteem, and hearing parents can have children with high self-esteem. Parents' hearing status is likely being used as a proxy for various environmental factors, such as parents' socialization practices, which may be more directly associated with self-esteem. The meta-analysis mentioned above also found that self-esteem was higher for those whose parents used sign language in the home, regardless of the parents' hearing status (Bat-Chava, 1993). Some hearing parents sign; some deaf parents do not sign. Parents' use of sign language in the home represents an aspect of Deaf cultural socialization. This suggests that socialization may predict self-esteem.

Satisfaction with life. The ethnic-racial socialization research has established that socialization predicts various measures of well-being (Neblett et al., 2008a; Rivas-Drake, 2011; Umaña-Taylor et al., 2004a; Yoon, 2001). Studies of socialization and satisfaction with life were not found for deaf samples in the current literature review. However, Deaf cultural socialization is expected to predict Deaf cultural identity, which has been found to be associated with well-being outcomes. For example, Maxwell-McCaw (2001) found that Deaf acculturation was

positively associated with satisfaction-with-life. Hintermair (2008) found Deaf acculturation predicted self-efficacy and well-being. Gordon (1998) found that those with Bicultural identities evaluate themselves and their present lives most positively. Deaf cultural socialization is, therefore, expected to predict positive well-being. The present study uses a measure of satisfaction with life as an indicator of well-being because it has been used and validated previously with deaf and hard of hearing samples (Hintermair, 2008; Maxwell-McCaw & Zea, 2011).

Mental health: Depression/anxiety. The present literature review did not find many studies that associated either the socialization or Deaf cultural identity of deaf individuals with measures of mental health. However, one study demonstrated that involvement with the Deaf community (an aspect of Deaf acculturation) was associated with less depression (Carter & Mireles, 2016). The ethnic-racial identity literature has reported associations between aspects of ethnic identity and lower levels of stress, depression, and anxiety (Neblett, Nicole, & Sellers, 2004; Rivas-Drake, 2012; Rivas-Drake, Hughes, & Way, 2008). Based on this foundational knowledge, both Deaf cultural socialization and Deaf cultural identity development are expected to be associated with less depression/anxiety.

Parents' hearing status. The literature review presented some evidence that deaf and hard of hearing individuals may have different developmental trajectories based on whether their parents are hearing or deaf (though contradictory evidence was also presented). To control for any potential confounding effects, parents' hearing status will be controlled for in hypothesis-testing analyses. This will allow for a clearer identification of the association between socialization and outcome variables.

Parents' hearing status is here trichotomized as having only hearing parents, having one deaf or hard of hearing parent, and having more than one deaf or hard of hearing parents. The distinction between one and two or more deaf or hard of hearing parents was made because there may be differences between such parent sets. The Deaf culture traditionally values homogamy, or intermarriage, as is demonstrated in the following quote from Lane, Hoffmeister, and Bahan's (1996) book, *A Journey into the DEAF-WORLD* ("DEAF-WORLD" is an English gloss, or an approximate translation of an ASL composite sign, here referring to the linguistic/cultural group associated with Deaf Culture)

The members of the DEAF-WORLD believe, as do members of other cultural groups, that one should marry within one's minority; marriage with a hearing person is frowned upon. Deaf marry Deaf approximately nine times out of ten (p. 71).

Therefore, parents who chose to marry fellow members of the Deaf community may be more Deaf-identified than those who chose to marry a hearing spouse (McLaughlin, 2012). The degree to which the parents are Deaf-identified will likely influence their socialization practices and their child's subsequent cultural identity development. This expectation is supported by the ethnic-racial socialization literature, which has demonstrated that parents' ethnic identity predicts their engagement in ethnic socialization (Hughes, 2003).

Relationship with parents. Remembered relationship with parents while growing up will be controlled for in the hypothesis-testing analyses. Parent-child relationships could be confounded with socialization practices, where stronger relationships may facilitate more conversations about the significance of hearing loss and greater acceptance of the child and his/her hearing status. Parent-child relationships also contribute to and predict mental health outcomes, in that difficult relationships and communication problems correlate with increases in

depressive symptoms (Crook, Raskin, & Eliot, 1981; McCranie & Bass, 1984). Retrospective reports of perceived maternal care have been found to be negatively correlated with depression in both hearing and deaf samples, while parental communication has been found to be negatively correlated with depression and positively correlated with self-esteem (Denollet et al., 2007; Leigh & Anthony, 1999; Leigh, Robins, Welkowitz, & Bond, 1989). It is therefore expected that parenting quality would correlate with mental health symptoms and well-being (in inverse directions).

Anecdotal reports of feeling overprotected and isolated while growing up appear throughout the Deaf research literature (e.g., Batten, Oakes, & Alexander, 2014; Byrnes, 2011; Chen, 2014; Crowe, 2003; Ford & Kent, 2013; Foster & Kinuthia, 2003; Hardin et al., 2014; Kemmery & Compton, 2014; Nikolarazi, 2007; Schorr, 2006; Whyte & Guiffrida, 2008). Relationship qualities may vary based on parents' hearing status. Lane (1999) suggests that "hearing parents of deaf children tend to be more manipulative, more tense and antagonistic, than deaf parents" (p. 159). Deaf individuals may be at risk for parent-child relationships characterized as alienating (e.g., due to the lack of full access to a shared language) or controlling (e.g., parents of deaf children may be seen as overprotective). Therefore, a measure of parent-child relationship featuring subscales of control and alienation was selected for the current investigation. These relationship qualities were considered aspects of negative parenting, and therefore expected to correlate positively with depression/anxiety and negatively with self-esteem and satisfaction with life.

Sociodemographic characteristics. Several characteristics of the individual, family, and school have been found to be associated with cultural identity and well-being outcomes. When applicable, these variables will be controlled for in the hypothesis-testing analyses in order to

more clearly elucidate the association between socialization and outcomes. Demographic characteristics reported here include gender, ethnicity, age, and education attained to date. Characteristics related to hearing and language include degree of hearing loss, age at identification of hearing loss, device usage, self-label, preferred communication, ability to sign, and English literacy. Family characteristics include parents' hearing status, parents' ability to sign, and family composition in the home while growing up. Characteristics related to school experiences include language of instruction, hearing status of students and teachers, and type of classroom (e.g., inclusive or segregated classroom or school).

The Present Study

This study has 2 objectives. First, it attempts to generalize patterns found in the ethnic-racial literature (i.e., associations between socialization and psychosocial outcomes) to the deaf and hard of hearing community. This objective is in response to the gap in the literature of the role of parents in the cultural identity and other psychosocial development of deaf and hard of hearing children. This study seeks to ascertain if the well-established research on ethnic-racial socialization applies to the Deaf cultural group.

Second, this study challenges the assumption that parents passively influence their child's cultural identity and well-being development based on an unchangeable characteristic, parents' hearing status. A hearing parent cannot become deaf, nor a deaf parent become hearing in order to influence their child's self-esteem or identity. Rather, this dissertation suggests that parents may play an active role as agents of socialization. The alternative focus accommodates the diversity likely found within the parent groups and seeks to demonstrate that, like transracially

adoptive families, hearing parents can effectively engage in cultural socialization of an unshared culture.

By focusing on parents' hearing status and group differences based upon it, the existing research misses the opportunity to identify specific parenting behaviors that are associated with positive outcomes. With an understanding of the beneficial behaviors, parents could adopt practices that promote healthy outcomes, regardless of their hearing status.

Research Question and Hypotheses

This study aims to answer the following research question: How is parental engagement in Deaf-specific socialization (i.e., Deaf cultural socialization and minority status socialization) associated with well-being and cultural identity outcomes in a sample of deaf and hard of hearing emerging adults?

H₀: Deaf-specific socialization is not associated with cultural identity and well-being outcomes.

H₁: Deaf-specific socialization (i.e., Deaf cultural socialization and minority status socialization) predicts Deaf cultural identity, specifically,

- a) Degree of Deaf acculturation
- b) Cultural identity status

H₂: Deaf-specific socialization (i.e., Deaf cultural socialization and minority status socialization) predicts self-esteem.

H₃: Deaf-specific socialization (i.e., Deaf cultural socialization and minority status socialization) predicts satisfaction with life.

H4: Deaf-specific socialization (i.e., Deaf cultural socialization and minority status socialization) predicts depression/anxiety.

Chapter 3

Method

Research Design

This dissertation is a quantitative study, with a cross-sectional correlational design and survey methodology in which deaf and hard of hearing emerging adults in the United States completed a one-time survey online.

The study was approved by the University of Wisconsin-Milwaukee Institutional Review Board (IRB #18.304).

Procedure

Recruitment. Qualtrics was paid to recruit participants for this study. Qualtrics is an online panel aggregator of many established consumer panels. Potential panels of participants are generated from a variety of sources, such as targeted email lists, customer loyalty programs, and member referrals. Members of these established panels have had their identity verified via third-party measures and have opted to participate in survey research. Use of an online panel aggregator is not well-established in Deaf identity research, and this will be addressed in the discussion.

Potential participants were offered an incentive to enroll in the study based on fair market value for the amount of time estimated for the survey. Qualtrics selected the specific value and form of the incentive based on the panel being used. For example, potential participants from an airline customer rewards program may have been offered SkyMiles, whereas participants from a retail or restaurant loyalty program may have been offered a gift certificate. Potential

participants were informed of the value and form of the incentive being offered prior to consenting.

Potential participants received an invitation to take the survey via email or a prompt within the related website (e.g., customer rewards website). The invitation clarified the incentive offered (estimated to be valued around \$10) and the amount of time estimated to complete the survey (i.e., 15 minutes). A hyperlink in the message directed participants to the description of the study and online consent form (see Appendix A). Three screening questions asked participants if they met the inclusion criterion: ages 18-25, from the United States, and deaf or hard of hearing. Those who self-reported meeting these criteria and consented to participate were then directed to the online, one-time survey. Qualtrics reported a response rate of 15.4%, based on the percentage of those who received the survey invitation that initiated the survey. No data was collected on those who did not initiate the survey.

A more typical means of recruitment is through flyers, emails, and website links distributed via college campuses with high deaf enrollment (e.g., Gallaudet University, RIT/NTID) or organizations that serve the Deaf population (e.g., the National Association of the Deaf). For example, Maxwell-McCaw (2001) recruited one of the largest samples in a Deaf identity study (N=3,070) through invitations disseminated by professionals in Deaf education and/or mental health, and organizations serving the deaf and hard of hearing populations, such as the National Association of the Deaf (NAD), the Association for Late Deafened Adults (ALDA), Self-help for Hard of Hearing (SHH), and students and alumni of universities with high-enrollment of deaf and hard of hearing students (e.g., Gallaudet, RIT/NTID). This atypical recruitment technique will be discussed in the final chapter.

While literacy may generally be presumed for a sample recruited online, the readability of the study description, consent, and survey poses a concern with a deaf and hard of hearing sample. American Sign Language may be the native language of some of the participants, making English a second language. Therefore, readability assessments available in Microsoft Word (an option of the Spelling and Grammar feature) were used to assess the grade level readability of the study description and consent (grade level 6.4) and survey items (see below for scale-by-scale readability). Whenever possible, the wording of various elements of the study were altered until the readability rating was acceptable. Providing access to the survey in ASL was considered but decided against. Few of the scales are presently available in ASL and previous research found that few participants use ASL versions when they are made available (Glickman, 1993).

Participants

Participants in the United States were selected because the theories, conceptualizations, and measures here applied are specific to an understanding of the Deaf culture of the United States, with its unique linguistic, social, political, and educational history (Erting, 1994; Holcomb, 2013; Padden & Humphries, 1988).

Emerging adulthood (i.e., ages 18-25) was selected for this study because identity development is a key feature of this developmental phase. Arnett (2000) asserts that emerging adulthood in American culture involves relative freedom from expectations and social roles, such as marriage and parenthood. This relative freedom allows for a prolonged period of role experimentation and exploration of possibilities in love, work, and worldviews. This extensive

exploration makes identity development particularly salient during emerging adulthood (Arnett, 2000).

For the deaf population, in particular, identity development may be stimulated by transitioning from living with their hearing family and attending a mainstreamed school to moving out, enrolling in a college or beginning a job that may connect them with a Deaf community. These transitions may expose the individual to new modes of communication and connections with individuals of similar life experiences that stimulate identity exploration (Holcomb, 1997; Wolsey et al., 2017; Meadow, 1972).

A total of 431 surveys were completed. Qualtrics recruitment has not been used and validated in previous studies of Deaf identity. Therefore, precautionary measures were taken to identify participants who may not have been taking the survey in earnest. A team of trained graduate students reviewed the survey responses to identify suspicious responses. Participants (n=40) were removed from the data set because they answered optional open-ended questions with unintelligible input (e.g., “Ggjbfgvhff”), out-of-context or meaningless word strings (e.g., “Soon box cold baby so hot cabbage”), or because they stated that they were not deaf or hard of hearing in any open-ended response fields. Participants who indicated that their degree of hearing loss was “normal-slight” (n=86) were also excluded from analyses, as these may be hearing individuals who did not answer the inclusion criteria question honestly (i.e., “Are you deaf or hard of hearing?”). The resulting analytical sample includes 305 participants. The means of the excluded sample (N=126) did not differ from the means of the analytic sample (N=305) on any of the study’s independent or dependent variables (see Table 1).

Table 1

Summary of ANOVA Comparing Means of the Excluded Sample (N=126) and the Analytic Sample (N=305) Across the Primary Study Variables

	Excluded Sample		Analytic Sample		<i>F</i>	<i>p</i>
	<i>M</i>	<i>SD</i>	<i>M</i>	<i>SD</i>		
Deaf Cultural Socialization	55.77	23.06	56.47	22.84	.08	.77
Minority Status Socialization	17.44	6.58	17.77	6.48	.23	.63
Deaf Acculturation	79.32	29.62	82.12	25.92	.96	.33
Hearing Acculturation	99.99	28.19	103.82	19.77	1.93 ^a	.17
Self-Esteem	25.76	5.42	26.08	5.41	.31	.58
Satisfaction with Life	21.36	7.99	21.15	7.02	.07 ^a	.80
Depression/Anxiety	9.94	3.64	9.94	3.56	.00	.99

Note. Total scale scores presented. ^a Homogeneity of variance assumption violated; Welch *F* reported.

Sociodemographic characteristics of the analytic sample. The characteristics of the analytic sample are presented next across the following domains: demographic characteristics, hearing/language-related characteristics, family characteristics, and school characteristics. (See Appendix B for survey items.) When available, comparable characteristics from the 2009-2010 Annual Survey of Deaf and Hard of Hearing Children and Youth is provided for comparison (Gallaudet Research Institute, 2011). This national data set from the Gallaudet Research Institute (GRI) reported on 37,828 deaf and hard of hearing students from the United States from preschool to 12th grade.

Demographic characteristics. Table 2 presents demographic characteristics of the analytic sample. Participants ranged in age from 18-25, with $M_{age}=21.6$ ($SD=2.4$). The sample was 72.5% female and 56.7% White. About 65% of the sample reported at least some college-level education to date.

The GRI demographic data are similar for ethnicity. The current sample's gender characteristics do not appear to be representative of the population (i.e., fewer male participants than the national sample).

Table 2

Demographic Characteristics of the Present Study (Husting; N=305) and Comparison Data from the Gallaudet Research Institute's (GRI) 2009-2010 Annual Survey of Deaf and Hard of Hearing Children and Youth, National Data

	Husting		GRI
	N	%	%
Gender			
Male	80	26.2	54.2
Female	221	72.5	45.8
Another	4	1.3	
Ethnicity			
White	173	56.7	46.6
Asian/Asian American	26	8.5	3.5
Hispanic/Latinx	38	12.5	25.3
Black/African American	31	10.2	14.8
American Indian/Alaska Native	4	1.3	.7
Multiracial or Other	33	10.8	9.1
Education Attained to Date			N/A
Did not complete high school (drop-out)	13	4.3	
Currently in or graduated high school	94	30.8	
Some college	129	42.3	
Completed Bachelor's degree	58	19.0	
Completed Master's degree or higher	11	3.6	

Hearing/language-related characteristics. Table 3 summarizes the hearing/language-related characteristics of the analytic sample. The majority of the sample reported mild to moderate hearing loss (69%). The most common self-label choices were “hard of hearing” (62.3%) and “hearing impaired” (17.7%). The majority of the sample reported that their hearing loss was diagnosed after the age of four (67.2%). Fifty-four percent of the sample use hearing aids; 7% use cochlear implants. Eighty-four percent preferred to communicate with a spoken language; 16% preferred a signed language (e.g., American Sign Language, Total Communication, Signed Exact English, Cued-Speech, Pidgin Signed English). Sixty-eight

percent of the sample reported knowing ASL, and of those, the majority learned it during their school years (i.e., age 5-17: 71.5%). The majority rated their English literacy as high (71.5%).

The GRI comparison data are similar for hearing aid usage (i.e., GRI=56.2%, current sample=54.4%), but higher for cochlear implant usage (i.e., GRI=14.7% current sample=6.9%). The GRI sample's hearing loss was identified at younger ages, with the majority identified before age 2 (i.e., GRI=55.5%, current sample=10.5%). The GRI students were spread out more evenly across the degrees of hearing loss, while the current sample had lower levels of hearing of loss.

Table 3
Hearing/Language-Related Characteristics of the Present Study (Husting; N=305) and Comparison Data from the Gallaudet Research Institute's (GRI) 2009-2010 Annual Survey of Deaf and Hard of Hearing Children and Youth, National Data

	Husting		GRI
	N	%	%
Self-Label Choice			No data
Hearing	22	7.2	
Deaf	35	11.5	
Hard of Hearing	190	62.3	
Hearing Impaired	54	17.7	
Other	4	1.3	
Degree of Hearing Loss			
Mild	126	41.3	27.7
Moderate	85	27.9	12.0
Moderately Severe	46	15.1	10.2
Severe	9	3.0	11.1
Profound	9	3.0	21.8
I do not know	30	9.8	17.2
Age at Identification ^a			
0-1 years old	32	10.5	55.1
2-3 years old	68	22.3	
4-10 years old	89	29.2	
11+ years old	116	38.0	
Device Usage			

None	116	38.0	
Hearing Aid	166	54.4	56.2
Cochlear Implant	21	6.9	14.7
Other	2	.7	
Preferred Mode of Communication			No data
Spoken English	249	81.6	
Other spoken language	6	2.0	
American Sign Language (ASL)	41	13.4	
Other sign language (e.g., SEE, TC, Cued)	8	2.6	
Do you know ASL?			No data
No	98	32.1	
Yes	207	67.9	
If yes, at what age did you learn ASL?			No data
0-4 years old	37	17.9	
5-10 years old	83	40.1	
11-17 years old	65	31.4	
18+ years old	22	10.6	
Self-Rated English Literacy			No data
Low	7	2.3	
Medium	80	26.2	
High	218	71.5	

Note. ^aGRI reports age of onset of hearing loss as at birth (40.7%), under two years of age (14.4%), two years of age or over (9.7%), and unknown (35.2%).

Family characteristics. Table 4 presents a summary of the family characteristics of the analytic sample. The majority of the sample had hearing parents (76.7%). Twenty-three percent of the sample had one or more deaf or hard of hearing parents. Fifty-five percent of the sample indicated that their parents did not use sign language with them while growing up. The majority of the sample (62%), grew up in a home with two parents.

The GRI data reported a comparable percentage of hearing parents and more than one deaf or hard of hearing parents. The GRI data differed from the current sample on the percentage with only one deaf or hard of hearing parent (i.e., GRI=5%, current sample=20%), which could be an artifact of the GRI reporting 14.4% missing data on one or more parent's

hearing status. The GRI data reported less family signing (i.e., GRI=23%, current sample 44.9%).

Table 4

Family Characteristics of the Present Study (Husting; N=305) and Comparison Data from the Gallaudet Research Institute's (GRI) 2009-2010 Annual Survey of Deaf and Hard of Hearing Children and Youth, National Data

	Husting		GRI
	N	%	%
Parents' Hearing Status^a			
Hearing parent(s) only	234	76.7	77.0
One D/HH parent	61	20.0	5.0
More than one D/HH parents	10	3.3	3.5
Parents Ability to Sign^b			
No parents signed	168	55.1	71.3
One parent signed	86	28.2	23.0
More than one parent signed	51	16.7	
Family Composition- Growing up lived with:			No data
One parent	71	23.3	
Two parents in same house	189	62.0	
More than one parent in separate houses	26	8.5	
Other caregiver(s)	6	2.0	
Missing data	13	4.3	

Note. ^aGRI reported 14.4% missing parent hearing status data. ^b GRI reported family members regularly sign (23.0%) and family members do not regularly sign (71.6%).

School characteristics. Table 5 presents the school characteristics of the analytic sample. Participants were asked to report “what their school was like most often growing up.” The majority of the sample was taught in a mainstream/inclusive classroom at a local school (64%), in spoken English (75%), with no (45%) or few (49%) deaf or hard of hearing peers in the classroom.

The most notable classroom type difference in the current sample and the GRI data is the proportion of students who attended special schools, which was much larger for the GRI students (i.e., GRI=24.3%, current sample=2.6%). The current sample was also more likely to be

educated in spoken language (i.e., GRI=53%, current sample=80%). The GRI survey did not delineate ASL from other signed modalities.

Table 5

School Characteristics of the Present Study (Husting; N=305) and Comparison Data from the Gallaudet Research Institute's (GRI) 2009-2010 Annual Survey of Deaf and Hard of Hearing Children and Youth, National Data

	Husting		GRI
	N	%	%
Classroom Type^a			
Mainstream/Inclusive	195	63.9	57.1
Special Education	61	20.0	11.9
D/HH classroom at local school	41	13.4	22.7
School for the Deaf (day or residential)	8	2.6	24.3
Language of Instruction^b			
Spoken English	229	75.1	53.0
Other spoken language	15	4.9	
American Sign Language	50	16.4	
Other sign language (e.g., SEE, Sim Com, TC, Cued)	11	3.6	44.5
D/HH Peers in Classroom			No data
0	136	44.6	
1-5	148	48.5	
More than 5	21	6.9	

Note. ^aGRI only had classroom type information for N=27,336. Options reported by GRI were general education school setting with hearing students (57.1%), Resource room (11.9%), Self-contained classroom in general education school setting (22.7%), special or center school (24.3%), home (3.1%), and other (3.9%). ^bGRI reported spoken language only (53.0%), sign language only (27.4%), sign supported spoken language (SIMCOM; 12.1%), spoken language with cues (5.0%), and other (2.5%).

School characteristics are likely to covary. A Deaf school classroom will be more likely to use sign language and contain deaf and hard of hearing peers, while a mainstream classroom will be more likely to use spoken English and not contain deaf and hard of hearing peers. To avoid potential issues of multicollinearity in the multiple regression analyses below, the three school variables were combined to form a school composite score indicating the degree to which the school was Deaf-centered. Classroom type was rated as 1=mainstream/inclusive, 2=special

education classroom, 3=classroom for deaf and hard of hearing, 4=school for the Deaf. Language of instruction was rated as 1=spoken English or other spoken language, 2=visual/signed system other than ASL, 3=ASL. Deaf and hard of hearing peers were rated as 1=0, 2=1-5, and 3=more than five. School composite scores ranged from three to ten, where higher scores indicated a more Deaf-centered school. The mean for the school composite score was 4.41 ($SD=1.48$).

Unique Sample Qualities

The present Qualtrics sample may be somewhat non-representative of the population. Noteworthy differences are here discussed to clarify the nature of this sample compared to previous works.

Comparisons. The Gallaudet Research Institute (GRI, 2011) collected the largest national data set ($N=37,828$) available for comparison of sociodemographic characteristics. Two Deaf identity studies are also here offered for sample comparisons: that of Maxwell-McCaw (2001) and Wolf Craig (2012). Maxwell-McCaw's (2001) sample is useful because it is quite large and recruited via many venues. However, it was published in 2001, so the participants were raised before several relevant changes took place, such as universal newborn hearing screenings, educational policies that favored mainstreaming, and technological advancements that reduced barriers between Deaf and Hearing cultures. Maxwell-McCaw's (2001) sample is also predominantly White (91%) and extends beyond emerging adulthood (age range 12-75; $M_{age}=35.7$, $SD=11.6$). The Wolf Craig (2012) study is smaller, but more recent, more ethnically diverse, and confined to emerging adulthood ($N=208$; recruited via Deaf colleges).

Education. The Qualtrics sample was educated primarily in mainstream school settings, with only 2.6% having attended a school for the Deaf. Conversely, over half of Maxwell-McCaw's (2001) older sample and a quarter of the GRI data set were educated in schools for the Deaf. Wolf Craig (2012) did not report educational background.

“Less deaf.” The Qualtrics sample is “less deaf” than the comparisons, as indicated by self-label, degree of loss, and age of identification. In this Qualtrics sample, only 12% self-labeled as *deaf*, preferring *hard of hearing* (62%) and *hearing impaired* (18%). In both Wolf Craig's (2012) and Maxwell-McCaw's (2001) samples, nearly 80% selected *deaf* or *Deaf*.

In the Qualtrics sample, 69% of participants had Mild and Moderate hearing loss, while the GRI data set reported 40% in this range. Maxwell-McCaw (2001) and Wolf Craig (2012) reported only 6.5% and 17.1%, respectively. These studies' low proportion compared with the GRI data set demonstrates how studies recruited via Deaf-centric organizations and universities may be systematically underrepresenting a subpopulation that is “less deaf,” audiologically and/or culturally, while the Qualtrics sample seems to overrepresent it.

This Qualtrics sample's hearing loss was also identified later in life (i.e., over half identified after age 4) than the GRI data set (i.e., over half identified before age 2). This difference may be partially explained by the fact that the GRI data set's birth years expand into the years in which states were implementing universal newborn screening laws, while the Qualtrics sample was born entirely before such laws were enacted. The GRI data set is also parent-reported, while the Qualtrics sample was self-reported. Emerging adults may not know the specifics of the identification of their hearing loss, as it likely occurred at a young age and parents may not speak openly about the experience. However, in Maxwell-McCaw's (2001)

sample, which is older than both the Qualtrics and GRI data sets, 84% were identified before age three.

Cultural identity differences. The present sample also differed from previous studies in cultural identity status proportions. This difference is evident in a comparison of the percentage of participants classified into the four cultural identity statuses for this sample and those of Wolf Craig (2012) and Maxwell-McCaw (2001; See Table 6). The current sample had an unusually high proportion of Hearing-identified and low proportion of Deaf-identified participants.

Table 6

Descriptive Summary of Cultural Identity for the Current Study and the Studies by Maxwell-McCaw (2001) and Wolf Craig (2012)

Cultural Identity	Husting	Maxwell-McCaw	Wolf Craig
Marginal	10.5	1	.5
Hearing	41.3	8	10
Deaf	5.2	52	31.9
Bicultural	43.0	39	55.7

Both Deaf and Bicultural identities are considered culturally Deaf (operationally, high in Deaf acculturation). Despite the low proportion of Deaf identities, a moderate proportion of the Qualtrics sample was classified as Bicultural; a proportion comparable to the other studies. This indicates that this sample did not lack orientation to the Deaf culture, but rather, it lacked a low orientation to the Hearing culture. The majority of the sample (84%) were classified as a cultural identity status high in Hearing acculturation (41% Hearing, 43% Bicultural). This likely reflects the sociodemographic characteristics mentioned above, such as high degree of mainstream education and low degree of hearing loss.

The extent to which this Qualtrics sample is affiliated with the Deaf-centric organizations of typical recruitment, and therefore overlaps with a typical sample, is not known. However, the sample's degree of involvement in the Deaf culture may be used as an indicator. This Qualtrics sample scored lower on the Deaf cultural involvement subscale of the Deaf Acculturation Scale (scores across parent hearing status groups ranged from 3.00-3.17 on the 5-point scale, $M=3.04$, $SD, 1.10$), while Maxwell-McCaw's sample was more involved ($M=4.22$, $SD=.80$ and $M=3.99$, $SD=.89$ for those with deaf and hearing parents, respectively).

The discussion chapter will contextualize the results and findings within the context of this unique sample.

Construction of the Scales

The Deaf Cultural Socialization Scale (DCSS; see Appendix C or Table 6) was developed for this dissertation to measure the extent to which emerging adults report that their parents socialized them regarding Deaf culture while they were growing up. The development of the measure was influenced by ethnic-racial socialization research and the writings of scholars on Deaf identity presented in the literature review.

As a foundation to the new measure, an existing scale of ethnic socialization was adapted to apply to Deaf culture. The 12-item Family Ethnic Socialization Measure (FESM; Umaña-Taylor, 2001; Umaña-Taylor et al., 2004a) measures adolescents' reports of the degree to which their families are socializing them regarding the family's ethnic culture. The FESM was selected for the development of the new scale because the FESM was intended to generalize across ethnic and cultural groups and because it distinguishes between modes of transmission.

Umaña-Taylor and colleagues (2001; 2004) distinguished between overt and covert socialization messages with two subscales: Overt and Covert. The FESM *Overt* subscale (5 items; e.g., “My family teaches me about the history of my ethnic/cultural background.”) assesses direct verbal instruction and intentional efforts to socialize regarding their ethnic culture. The FESM *Covert* subscale (7 items; e.g., “My family celebrates holidays that are specific to my ethnic/cultural background.”) assesses inadvertent and nonverbal socialization regarding ethnic culture based on parental modeling or choice of activities.

The Overt and Covert subscales were renamed *Verbal* and *Nonverbal* for this dissertation. This was done because the Covert subscale of the Family Ethnic Socialization Measure was intended for culturally homogenous families in which parents would be engaging in their own cultural behaviors without necessarily doing so to transmit messages to the children. This covert style of inadvertent socialization may be prevalent in multi-generational Deaf families. Conversely, the vast majority of parents of deaf and hard hearing individuals are not themselves culturally Deaf. Therefore, their modeling of cultural behaviors and community involvement would not be inadvertent, daily life. Rather, parents would likely be intentionally exposing the child to Deaf culture through modeling and selected activities for the sake of engaging in cultural socialization. The labels, *verbal* and *nonverbal*, reflect the mode of expression, without specifying the intent of the socialization, as the *overt* and *covert* labels do. This distinction allows the measure to be applied to both deaf and hearing parent groups, but must be kept in mind during interpretation of the results.

To apply this measure to the present study, items were adapted as follows (see Appendix C for side by side comparison): a) Present tense items (intended for adolescents) were reworded to be past tense (intended for emerging adults); b) References to the family were changed to refer

to parent(s); and c) References to the family’s ethnic/cultural background were changed to refer to Deaf culture. For example, “My family teaches me about our family’s ethnic/cultural background,” became, “My parent(s) taught me about Deaf culture.”

In addition to the adapted FESM items, this author wrote additional items for the scale specific to aspects of socialization that are salient to Deaf cultural identity development. Specifically, items were added related to ASL, as it is the language of the Deaf culture and is required for meaningful connections within the Deaf community. As Padden and Humphries (2009) stated, “Becoming a signer is a process of socialization in the same way it is a process of socialization to become a deaf nonsigner” (p. 160). Several items were added related to promoting contact with Deaf peers and adults. Social identity theory tells us that identity develops through continuous interactions and social comparison with other group members (H Tajfel, 1981). Since the majority of parents are not deaf, this contact with Deaf community members can provide cultural brokers and mentors for the parents and children alike. Other items address how positive and salient the parents made the hearing loss.

Items were added to both the Verbal and Nonverbal subscales (see Table 7). Additional *Verbal* items (5 items; e.g., “My parent(s) taught me to be proud to be deaf.”) relate to promoting Deaf Pride, Deaf community membership, and the use of ASL through direct verbal messages and instruction. Additional *Nonverbal* items (3 items; e.g., “My parent(s) exposed me to deaf adults.”) relate to connecting with the Deaf community via their shared language and mentors through parental modeling and choice of activities. Overall, these additions to the scale reflect experiences that would likely promote cultural competence, language competence, and a sense of belonging in the Deaf community (aspects of cultural identity).

Table 7

20-Item Deaf Cultural Socialization Scale with Source and Expressive Mode of Transmission

Adapted FESM Items (Umaña-Taylor et al., 2004)^a

Verbal	Nonverbal
My family taught me about the Deaf culture.	My family participated in Deaf cultural activities.
My family encouraged me to respect the cultural values and beliefs of the Deaf culture.	Our home was decorated with things that reflected the Deaf culture.
My family taught me about the values and beliefs of the Deaf culture.	The people who my family hung out with the most were people who share the Deaf cultural background.
My family talked about how important it is to know about the Deaf culture.	My family participated in events that celebrated Deaf culture (like Deaf Awareness week or culture festivals).
My family taught me about Deaf history.	My family enjoyed music, dance, or storytelling by Deaf performers. My family attended things such as concerts, plays, festivals, or other events that represent the Deaf culture. My family felt a strong attachment to the Deaf culture.

Additional Deaf-Specific Items (Husting, in progress)^b

Verbal	Nonverbal
My parent(s) taught me to be proud to be deaf.	My parent(s) used sign language around me.
My parent(s) talked openly about deafness.	My parent(s) exposed me to deaf adults.
My parent(s) encouraged me to have deaf friends.	My parent(s) took me places to meet other deaf people.
My parent(s) talked to me about the value of American Sign Language.	
My parent(s) talked to me about the value of the Deaf community.	

Note. ^aAdaptation of 12 items from the Family Ethnic Socialization Measure (FESM; Umaña-Taylor & Fine, 2001). ^bAdditional eight Deaf-Specific Socialization items written for this study (Husting, in progress).

The DCSS was originally conceptualized as containing three socialization subscales (i.e., Verbal, Nonverbal, and Minority Status). *Minority Status socialization* assesses the degree to

which parents transmit messages about discrimination and how to cope with or overcome such difficulties associated with being minoritized (i.e., due to being deaf).

The minority status items were written by this author and influenced by models of socialization, such as that of Brown & Krishnakumar (2007), which distinguished between ethnic socialization and racial socialization. In their model, *ethnic socialization* referred to parents' messages related to cultural heritage and history, and promotion of ethnic pride. *Racial socialization*, in their model, referred to parents' messages related to racial barrier awareness and how to cope with racism and discrimination. The minority status items were intended to measure similar socialization messages regarding being a member of a minoritized group, in this case, based on hearing status, rather than race. The Minority Status scale includes items regarding discrimination and promotion of mistrust of the majority group (i.e., hearing people). It also includes items related to teaching the child to advocate for their accommodation needs and teaching the child about legal rights and community action.

Upon further consideration, it was decided that the Minority Status subscale should be removed from the DCSS and used as an independent scale, the Minority Status Socialization Scale (MSS). This decision was made for multiple reasons. Firstly, the Minority Status scale items were all overt, verbal messages, which confounded the distinction based on modes of transmission in the Verbal and Nonverbal subscales of the DCSS. Secondly, it became apparent, upon further reflection and preliminary exploration of the data, that while the DCSS may be seen as a measure of parents' messages about how to function successfully in the Deaf world, the Minority Status items measure parents' messages about how to function successfully in hearing society as a deaf or hard of hearing person. This distinction runs parallel with that of Brown & Krishnakumar (2007), with the DCSS Verbal and Nonverbal subscales measuring the Deaf

cultural approximation of ethnic socialization (across the two modes of transmission), and the minority status subscale measuring the Deaf cultural approximation of racial socialization.

While these constructs are related, they are distinct and should be measured separately.

Two scales were ultimately constructed, the 20-item Deaf Cultural Socialization Scale (DCSS; see Table 7 and Appendix C) and the 6-item Minority Status Socialization Scale (MSS; see Table 8 and Appendix D).

Table 8

6-Item Minority Status Socialization Scale (MSS)

-
- My parent(s) told me to stand up for the rights of the Deaf community.
 - My parent(s) warned me that I might be treated badly because I am deaf.
 - My parent(s) taught me to stand up for my accessibility needs.
 - My parent(s) taught me about my legal rights as a deaf or hard of hearing person.
 - My parent(s) talked to me about how to handle discrimination.
 - My parent(s) warned me to not trust hearing people.
-

For face validity, items for the DCSS and MSS were developed based on review of the ethnic-racial socialization literature (e.g., Brown & Krishnakumar, 2007; Hughes & Chen, 1997) and the Deaf identity literature (Bat-Chava, 2000; Leigh, 2009; Maxwell-McCaw et al., 2000). Items were also influenced by interviews this author conducted with hearing mothers regarding their perspectives and practices regarding raising deaf and hard of hearing children; particularly the minority status items (Husting, 2018). This author then discussed the items with a focus group of three deaf and hard of hearing emerging adult students and employees at the author's university. Feedback was received and applied regarding the content and wording of scale items. The items were also reviewed by a culturally Deaf research associate from the Rochester Institute of Technology/National Technical Institute for the Deaf (RIT/NTID) and a Deaf identity

expert retired from Gallaudet University. Their feedback lead to edits and the addition of an item.

Measures

Independent variables. The independent, or predictor, variables for this study are two aspects of socialization related to being deaf: Deaf cultural socialization and minority status socialization.

Deaf cultural socialization. The Deaf Cultural Socialization Scale (DCSS; see Table 7 or Appendix C) was developed for this study (see Construction of the Scales above) to measure the extent to which emerging adults report that their parents socialized them regarding the Deaf culture. The 20-item scale can be divided into two subscales that delineate two expressive modes of transmission: verbal and nonverbal socialization.

The *Verbal* subscale (10 items; e.g., “My family teaches me about the history of my ethnic/cultural background.”) assesses direct verbal instruction and intentional efforts to socialize regarding Deaf culture, such as messages related to promoting Deaf Pride, Deaf community membership, and the value of American Sign Language through direct verbal instruction and messages.

The *Nonverbal* subscale (10 items; e.g., “My parent(s) exposed me to deaf adults.”) assesses nonverbal socialization related to connecting with the Deaf community via their shared language and mentors through parental modeling and choice of activities.

The instructions on the survey indicated that when items refer to “parent(s),” participants should “think about whomever your primary caregiver(s) were” and to think about what they “said and did while you were growing up.” Participants rated their agreement with the items

based on a 5-point Likert scale from 1 (*not at all true*) to 5 (*very much true*). The DCSS was scored as a total score based on the results of the factor analyses (presented in the Results chapter). The DCSS can also provide separate subscale scores for the expressive modes of transmission (i.e., Verbal and Nonverbal) in future studies. Higher scores indicate more perceived Deaf cultural socialization. Cronbach's α was .97 for the total scale and .94 and .94 for the Verbal and Nonverbal subscales, respectively.

The readability of the Deaf Cultural Socialization Scale was rated as grade level 6.8.

Minority status socialization. The Minority Status Socialization Scale (MSS; Table 8 and Appendix D) was developed for this study (see Construction of the Scales above) to measure the degree to which parents transmit messages about discrimination and how to cope with or overcome such difficulties associated with being a member of a minoritized group.

Participants rated their agreement with the six items based on a 5-point Likert scale from 1 (*not at all true*) to 5 (*very much true*). Higher scores on the MSS indicate more perceived minority status socialization. Cronbach's α was .85.

The readability of the Minority Status Socialization Scale was rated as grade level 5.6.

Dependent variables. The dependent variables include cultural identity (i.e., Deaf acculturation, Hearing acculturation, cultural identity status), self-esteem, satisfaction with life, and depression/anxiety.

Cultural identity. The Deaf Acculturation Scale (DAS; see Appendix E; Maxwell-McCaw & Zea, 2011) is an established measure of cultural identity and acculturation among deaf and hard of hearing populations (Leigh et al., 2009; Maxwell-McCaw et al., 2000; Maxwell-McCaw & Zea, 2011). Two parallel scales measure the degree of Deaf acculturation and

Hearing acculturation, respectively, based on cultural identification, cultural involvement, cultural preferences, cultural competence, and language competence. The two parallel cultural scales each contain 29 items, each rated on a 5-point Likert scale ranging from 1 (*strongly disagree or not at all*) to 5 (*strongly agree, a great deal, or excellent/like a native*). Degree of acculturation is reported as the average score on each culture scale (i.e., ranging from 1-5), where higher scores indicated greater degree of acculturation.

The DAS can also be used to provide a snapshot of cultural identity status (Marschark et al., 2017). The average score on each culture scale was categorized as low or high based on a mathematical median-split (i.e., the scale value of three; Maxwell-McCaw, 2001) and used to create four cultural identity statuses: Marginal (below the median in both Deaf and Hearing Acculturation), Hearing (below the median in Deaf Acculturation and above the median in Hearing Acculturation), Deaf (above the median in Deaf Acculturation and below the median in Hearing Acculturation), and Bicultural (above the median in both Deaf and Hearing Acculturation).

The number of participants in each cultural identity status for this sample was: Marginal=10.5%, Hearing= 41.3%, Deaf= 5.2%, and Bicultural=43.0%. For comparison, a recent dissertation that recruited at two college campuses with high enrollments of deaf students (i.e., Gallaudet University and Rochester Institute of Technology) reported Marginal=.5%, Hearing=10%, Deaf=31.9%, and Bicultural=55.7% ($N=208$; Wolf Craig, 2012). The current sample had an unusually high proportion of Hearing-identified and low proportion of Deaf-identified participants. This will be discussed further in the discussion.

In the present analysis, Cronbach's alpha was .96 for the Deaf cultural scale and .93 for the Hearing cultural scale. These results are very similar to the original work by Maxwell-McCaw (2001), which reported Cronbach's alpha of .96 and .91, respectively.

The readability of the Deaf Acculturation Scale was rated as grade level 5.9.

Self-esteem. The Rosenberg Self-Esteem Scale (1989; See Appendix F) assesses global, personal self-esteem with ten items that are rated on a 4-point scale ranging from 1 (*strongly disagree*) to 4 (*strongly agree*). Items include, "On the whole, I am satisfied with myself" and "I feel that I have a number of good qualities." Higher scores indicate more positive self-esteem. This scale has previously demonstrated high Cronbach's alpha of .82 with a deaf sample (Hintermair, 2008), and in the present analysis the alpha was .80.

The readability of the Rosenberg Self-Esteem scale was rated as grade level 3.1.

Satisfaction with life. The Satisfaction with Life Scale (See Appendix G; Diener, Emmons, Larsen, & Griffin, 1985) assesses subjective well-being globally. The scale consists of 5 items that are rated on a 7-point Likert scale ranging from 1 (*strongly disagree*) to 7 (*strongly agree*). Items include, "In most ways my life is close to my ideal," and "I am satisfied with my life." Higher scores indicate greater satisfaction. Diener et al. (1985) originally reported a coefficient alpha of .87. Studies using the scale with the Deaf population have reported coefficient alphas of .86 and .87 (Hintermair, 2008; Maxwell-McCaw, 2001). In the present analysis, the alpha was .88.

The readability of the Satisfaction with Life Scale was rated as grade level 3.1.

Depression/Anxiety. The Patient Health Questionnaire (PHQ-4; See Appendix H; Kroenke, Spitzer, Williams, & Löwe, 2009) was used to assess depression and anxiety. Items

ask how many days in the past 2 weeks has the participant has been bothered by things such as “feeling nervous, anxious, or on edge,” and having “little interest or pleasure in doing things.” Higher scores indicate more depression and anxiety. Kroenke et al. (2009) reported Cronbach’s alpha of .85. In the present analysis, the alpha was .88.

The readability of the Patient Health Questionnaire was rated as grade level 6.7.

Control Variables. Parents’ hearing status and relationship with parents may be confounded with parental engagement in socialization and associations with outcome variables. Therefore, parent’s hearing status and relationships with parents were treated as control variables in the hypothesis-testing analyses.

Parents’ hearing status. A demographic survey items asked participants to identify their parent’s hearing status as one of three options: hearing parents only, one deaf or hard of hearing parent, or two or more deaf or hard of hearing parents.

Relationship with parents. The Remembered Relationships with Parents Scale (RRPS; See Appendix I; Denollet, Smolderen, van den Broek, & Pedersen, 2007) is a 10-item retrospective self-report scale that assesses the parent-child relationship while growing up across two domains of empathic parenting: Alienation and Control.

The *Alienation* subscale (5 items; e.g., “I kept my troubles to myself.”) assesses the degree to which reporters felt alienated from their parents growing up.

The *Control* subscale (5 items; e.g., “My parents’ worried that I couldn’t take care of myself.”) assesses the degree to which reporters remembers their parents being controlling and overprotective.

Items are rated on a 5-point Likert scale ranging from 1 (*false*) to 5 (*true*). Higher scores on either subscale reflect memories of more negative relationships (i.e., more controlling or more alienating). In the original study, the two subscales were moderately correlated ($r=.38$) and Cronbach's alphas for the Alienation and Control subscales were .83 and .86, respectively (Denollet et al., 2007). In the present analysis, the alphas were .82 and .76, respectively, and the scales were moderately correlated ($r=.60, p=.000$).

The readability of the Remembered Relationship with Parents Scale was rated as grade level 5.7.

Sociodemographic characteristics. The sample characteristics presented in the sociodemographic section above were measured within the demographic survey items (see Appendix B). The readability of these items was rated as grade level 3.3.

Analytic Plan

The two new measures of socialization were explored with factor analysis to evaluate their factor structure. Confirmatory factor analysis was used first to determine if the factor structure of the FESM (Overt and Covert subscales) emerged with the current data set. Exploratory factor analysis was then used to determine the factor structure of both the DCSS and the MSS. Predictive validity was evaluated by the scales' ability to predict Deaf acculturation. Concurrent validity was evaluated by the scales' ability to distinguish between cultural identity status groups. Discriminant validity was evaluated by the scales' correlations with quality of relationship with parents.

A thorough review of the descriptive characteristics of the study variables are presented to provide familiarity with the variables and their inter-relationships. To explore the validity of

the assumption presented in the literature about the deterministic nature of parents' hearing status, each of the study's measured variables were compared across parent hearing statuses. To provide a full understanding of engagement in socialization, DCSS and MSS scores were compared across levels of the sociodemographic characteristics. The association among study variables, and among the sociodemographic characteristics and the outcome variables were then presented to inform the hypothesis-testing analyses.

Hypotheses 1A, 2, and 3 were evaluated with hierarchical regression analyses. Hierarchical regressions were chosen because the outcome variables are continuous, and the various confounding variables can be controlled for in separate steps, which enabled the exploration of the contributions made to explaining variability in the outcome variables at each step.

Hypothesis 1B was evaluated with multinomial logistic regression analysis because the outcome variable, cultural identity status, is a categorical variable (i.e., Marginal, Hearing, Deaf, and Bicultural identity statuses determined by the Deaf Acculturation Scale) being predicted by a continuous variable (i.e., DCSS or MSS).

Chapter 4

Results

Preliminary analyses are presented before hypothesis testing. The Deaf Cultural Socialization Scale (DCSS) and the Minority Status Socialization Scale (MSS) were developed for the current investigation and required evaluation of their factor structure, reliability, and validity before being used for hypothesis testing. The descriptive and correlational results are then reported for the study variables. A series of analyses of variance (ANOVAs) are then presented to explore group difference in socialization across the sociodemographic characteristics. Finally, results of hypotheses-testing analyses are presented.

Analyses were conducted using SPSS 25 or Amos 25. All test statistics are evaluated at the $p \leq .05$ level.

Preliminary Analyses: Factor Structure, Reliability, and Validity

Confirmatory and exploratory factor analyses were employed to determine the factor structure of the two new measures of socialization.

Deaf Cultural Socialization Scale. The Deaf Cultural Socialization Scale (DCSS) was based on an adaptation of the Family Ethnic Socialization Measure (FESM; Umaña-Taylor & Fine, 2004; Umaña-Taylor et al., 2004). Accordingly, a confirmatory factor analysis was performed to determine if the two-factor (i.e., Overt and Covert) model of the FESM fit the current data set. Five cases were omitted from the analysis due to missing data, therefore the sample for the confirmatory factor analysis was $N=300$. A path diagram was created based on the 12 adapted FESM items only, with five items loading on an Overt (now known as Verbal)

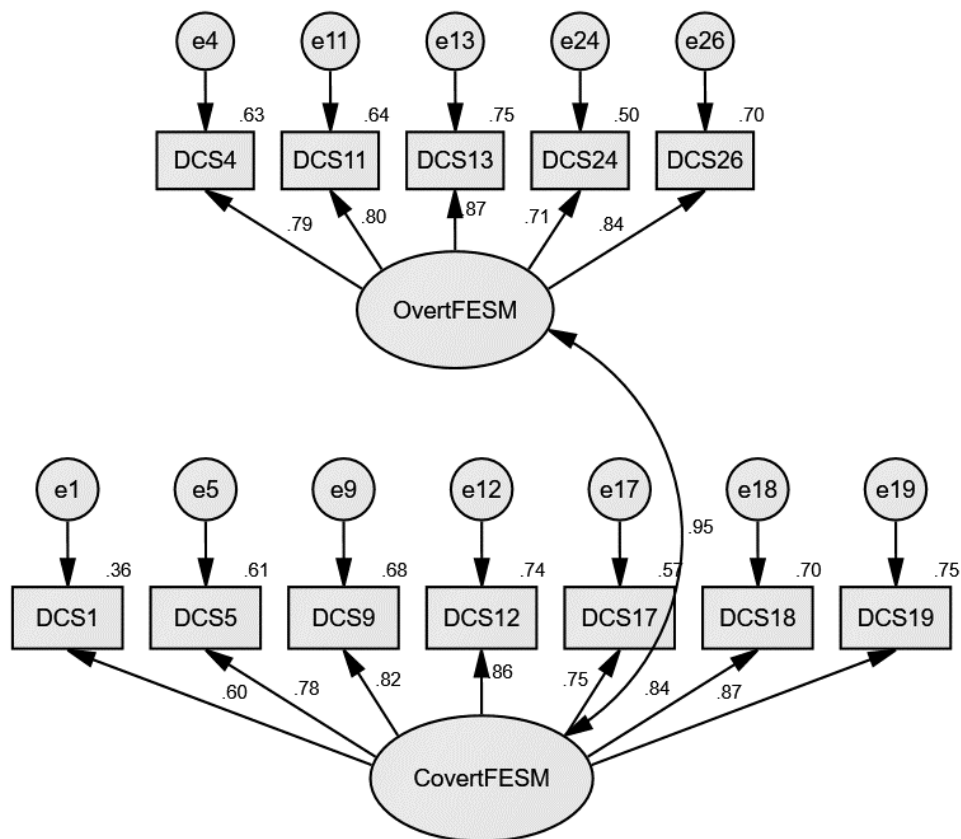

Figure 1. Confirmatory Factor Analysis for 12 adapted Family Ethnic Socialization Measure items. Standardized factor loadings on arrows and portion of variance explained in superscripts.

factor and seven items loading on a Covert (now known as Nonverbal) factor (see Figure 1). Standardized factor loadings for Overt and Covert items ranged from .60-.87, and .71-.87, respectively. The model was not a good fit for the data ($\chi^2=227.6$, $df=53$, $p=.000$; RMSEA=.10; AGFI=.83; RMR=.08). Kline (2015) suggests that cut-offs for a good fit are: $\chi^2 p$ -value greater than .05, RMSEA less than .08, AGFI greater than .9, and RMR less than .08. None of these cut-

offs are met with the initial analysis. Following the recommendations of the modification indices provided by the AMOS statistics software, several error terms were allowed to covary, which improved the model somewhat ($\chi^2 = 88.0$, $df=39$, $p = .000$; RMSEA=.07; AGFI=.91; RMR=.05), but not enough to satisfy all goodness of fit cut-offs.

A second confirmatory factor analysis was performed with the full 20-items of the DCSS and the 2-factor structure suggested by the FESM. A path diagram was created with ten items loading on the Overt factor and ten items loading on the Covert factor (see Figure 2). Standardized factor loadings for Overt and Covert items ranged from .62-.86 and .61-.86, respectively. The model was not a good fit for the data. ($\chi^2 = 595.1$, $df=169$, $p = .000$; RMSEA=.09; AGFI=.79; RMR=.09). None of the suggested cut-offs are met with the initial analysis. Following the recommendations of the modification indices provided by the AMOS statistics software, several error terms were allowed to covary, which improved the model somewhat ($\chi^2 = 337.9$, $df=143$, $p = .000$; RMSEA=.07; AGFI=.86; RMR=.07), but not enough to satisfy all goodness of fit cut-offs.

Due to the lack of good fit with the 2-factor, Overt/Covert model (now known as Verbal/Nonverbal), in the confirmatory factor analyses, an exploratory factor analysis was performed on the DCSS.

The data were first evaluated to determine if a factor analysis was appropriate. The sample size ($N=305$) met the recommendations of at least 300 and with at least 10 participants per scale item (i.e., 200 participants required for 20 items; Yong & Pearce, 2013). The correlation matrix of the 20-items indicated that all items were reasonably correlated, $r=.41-.79$ (i.e., meeting the recommended cut-offs of above .30 and below .90; Yong & Pearce, 2013).

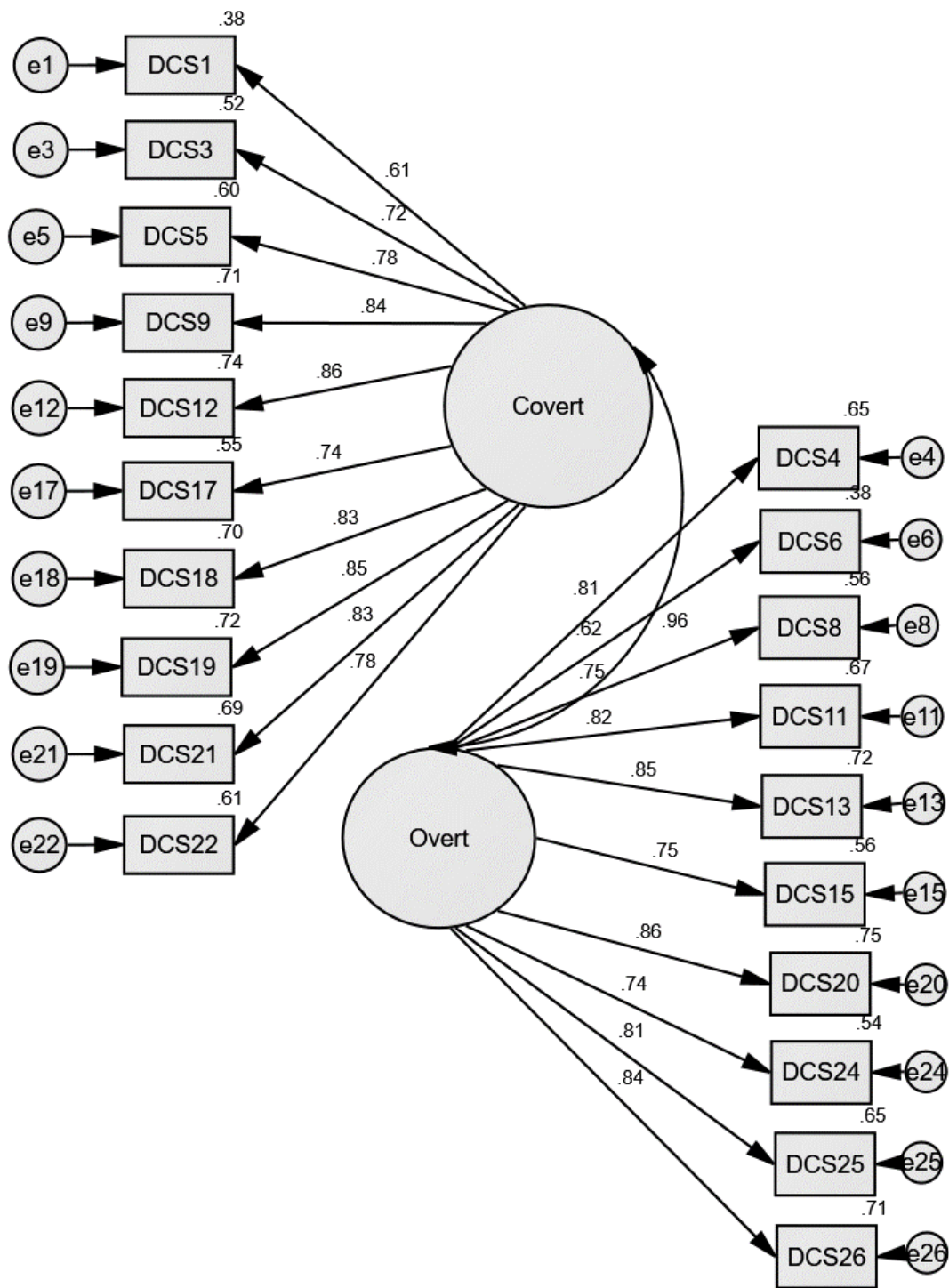

Figure 2. Confirmatory Factor Analysis for 20-item Deaf Cultural Socialization Scale. Standardized factor loadings on arrows and portion of variance explained in superscripts.

Bartlett's Test of Sphericity was significant at $p=.000$; with $p<.05$ indicating a patterned relationship among the items (Yong & Pearce, 2013). The Kaiser-Meyer Olkin (KMO) Measure was .96 (i.e., above the recommended cut-off of .50; Yong & Pearce, 2013). Measures of sampling adequacy (MSA) ranged from .94-.99; all exceeding the rule of thumb of .50 (Yong & Pearce, 2013), indicating that distinct and reliable factors can be produced from the data. These results all indicate that factor analysis is appropriate for this data set.

To remove multivariate outliers, cases ($n=18$) in which the Mahalanobis distance exceeded the critical distance of 45.31 ($df=20$, $p=.001$) when predicting Deaf Acculturation were omitted. Cases with missing data were omitted pairwise ($n=3$). The resulting sample size was $N=284$. A maximum likelihood extraction with oblique rotation identified one factor (Eigenvalue=13.24), which explained 64.5% of the variance. The second factor identified was below, but approached, the Eigenvalue cut-off value of one (factor 2 Eigenvalue=.90). It explained less than 3% of variance, and produce very small and incoherent factor loadings, therefore only one factor is retained. Item-factor loadings ranged from .65 to .89 (see Table 9).

The 20-item DCSS demonstrated strong reliability, with a Cronbach's α of .97. DeVellis's (2016) suggests that alphas above .80 are very good. All items performed reliably. Corrected item-total correlations ranged from $r=.62$ -.84. Cronbach's α -if-item-deleted ranged from $r=.965$ -.968. Based on these analyses, the DCSS was treated as a single-factor measure of overall Deaf cultural socialization throughout the analyses presented below. (See Appendix J to see a summary of analyses using the 2-factor, Verbal/Nonverbal distinction.)

Table 9

*Exploratory Factor Analysis of the 20-item Deaf Cultural Socialization Scale (DCSS); 1
Factor*

DCSS Item	Factor	M	SD
My parent(s) talked to me about the value of the Deaf community. DCSS20	.89	2.89	1.51
My parent(s) participated in events that celebrated Deaf culture (like Deaf Awareness events). DCSS12	.88	2.71	1.40
My parent(s) taught me about Deaf history. DCSS13	.86	2.76	1.47
My parent(s) felt a strong attachment to Deaf culture. DCSS19	.86	2.61	1.43
My parent(s) participated in Deaf cultural activities. DCSS9	.85	2.74	1.42
My parent(s) took me places to meet other deaf people. DCSS21	.85	2.7.3	1.46
My parent(s) talked about how important it is to know about Deaf culture. DCSS11	.85	2.85	1.47
My parent(s) taught me about the values and beliefs of the Deaf culture. DCSS26	.84	3.03	1.55
My parent(s) taught me about Deaf culture. DCSS4	.84	2.93	1.47
My parent(s) attended things such as concerts, plays, festivals, or other events that represent the Deaf culture. DCSS18	.84	2.53	1.39
My parent(s) talked openly about being deaf. DCSS25	.82	3.12	1.53
My parent(s) used American Sign Language with me. DCSS22	.82	2.75	1.51
Our home was decorated with things that reflected Deaf culture. DCSS5	.78	2.53	1.47
My parent(s) talked to me about the value of American Sign Language. DCSS8	.76	3.03	1.49
My parent(s) taught me to be proud to be deaf. DCSS15	.76	3.19	1.47
My parent(s) exposed me to deaf adults. DCSS3	.74	2.84	1.44
The people who my family hung out with most were people who shared the Deaf cultural background. DCS17	.73	2.30	1.36
My parent(s) encouraged me to respect the values and beliefs of the Deaf culture. DCSS24	.73	3.24	1.45
My parent(s) encouraged me to have deaf friends. DCSS6	.65	3.09	1.37
My parent(s) enjoyed songs, music, dance, or storytelling by Deaf performers. DCSS1	.65	2.66	1.42
	Eigenvalue	13.24	
	% of variance	64.46	
	Cronbach's alpha	.97	

Note. The DCSS is rated on a 5-point Likert scale from 1 (*not at all true*) to 5 (*very much true*).

Minority Status Socialization Scale. The Minority Status Socialization Scale (MSS) was not developed with a preconceived expectation of factor structure, therefore exploratory factor analysis was used to evaluate its factor structure.

The data was first evaluated to determine if a factor analysis was appropriate. The sample size ($N=305$) met the recommendations of at least 300 and with at least 10 participants per scale item (i.e., 60 participants required for 6 items; Yong & Pearce, 2013). The correlation matrix of the 6-items indicated that 5 of the items were reasonably correlated, ranging from $r=.51-.66$ (i.e., meeting the recommended cut-offs of above .30 and below .90; Yong & Pearce, 2013). However, Item 6 showed low correlations with other items, ranging from $r=.20-.35$ (discussed further below). Bartlett's Test of Sphericity was significant at $p=.000$, indicating a patterned relationship (Yong & Pearce, 2013). The Kaiser-Meyer Olkin (KMO) Measure was .88 (i.e., above the recommended cut-off of .50; Yong & Pearce, 2013). Measures of sampling adequacy (MSA) ranged from .79-.91 (i.e., above the recommended cut-off of .50; Yong & Pearce, 2013). These results all indicate that factor analysis is appropriate for this data set.

To remove multivariate outliers, cases ($n=4$) in which the Mahalanobis distance exceeded the critical distance of 22.46 ($df=6, p=.001$) when predicting Deaf Acculturation were omitted. Cases with missing data were omitted pairwise ($n=5$). The resulting sample size was $N=296$. An exploratory factor analysis with maximum likelihood extraction and oblique rotation found a single factor (Eigenvalue=3.56), which explained 52.2% of the variance. The second factor identified was below the Eigenvalue cut-off value of one (factor 2 Eigenvalue=.88), and therefore only one factor is retained. Factor loadings ranged from .35-.86. Item 6, "My parent(s) warned me to not trust hearing people," did not perform well. It loaded at .35, which is below

the minimum rule of thumb cut-off of .40 (Matsunaga, 2010), while the other items loaded at .70-.86. Item 6 correlated weakly with the other items ($r=.20-.35$).

The 6-item scale was acceptably reliable (Cronbach's $\alpha=.85$). The corrected item-total correlation for Item 6 was only $r=.34$. Item 6 was the only item whose removal would improve the scale's alpha. Due to its overall poor performance, Item 6 was dropped from the scale.

A second exploratory factor analysis with the 5-item MSS was found to again have a single factor (Eigenvalue =3.39), which explained 60% of the variance. The second factor identified was well below the Eigenvalue cut-off value of one (factor 2 Eigenvalue=.51), and therefore only one factor is retained. Factor loadings ranged from .69-.87 (see Table 10).

The 5-item MSS was reliable, with a Cronbach's $\alpha=.87$. All items now performed reliably. Inter-item correlations ranged between $r=.51-.66$. Corrected item-total correlations ranged from .65-.77. And no item-deletion would improve the reliability of the scale.

Due to the better performance of the 5-item scale over the 6-items scale (e.g., improvement in the portion of variance explained, stronger factor loadings), the MSS was treated as a single-factor, 5-item measure of overall minority status socialization throughout the analyses presented below.

Table 10

Exploratory Factor Analysis of the 5-item Minority Status Socialization Scale (MSS); 1-Factor

	Factor	M	SD
My parent(s) taught me to stand up for my accessibility needs.	.87	3.24	1.45
My parent(s) talked to me about how to handle discrimination.	.80	3.42	1.41
My parent(s) taught me about my legal rights as a deaf or hard of hearing person.	.76	3.05	1.50
My parent(s) warned me that I might be treated badly because I am deaf.	.74	2.96	1.42
My parent(s) told me to stand up for the rights of the Deaf community.	.69	3.10	1.46
Eigenvalue	3.39		
% of variance	60.01		
Cronbach's alpha	.87		

Note. The deleted item (MSS item 6) had a M=2.05, SD=1.37. The MSS is rated on a 5-point Likert scale from 1 (*not at all true*) to 5 (*very much true*)

Validity of the DCSS and MSS. Criterion-related validity of the DCSS and MSS were assessed via predictive, concurrent, and discriminant validity checks.

Predictive validity. Socialization theory posits that socialization predicts cultural identity development. For example, parents' efforts to facilitate their child's participation in cultural activities, model this participation, and encourage their child's exposure to and identification with the cultural group (i.e., cultural socialization) lead the child to imitate and adopt the cultural practices, preferences, and identification with the cultural group (i.e., aspects of cultural identity; Grusec & Davidov, 2010). Therefore, a positive moderate to strong association between the DCSS and Deaf acculturation would demonstrate predictive validity. The DCSS was, in fact, strongly correlated with Deaf acculturation ($r=.80, p=.000$).

To a lesser degree, a similar association was expected for the MSS and Deaf Acculturation. Parents' efforts to promote their child's ability to advocate for themselves and

cope with experiences of discrimination based on hearing status (i.e., minority status socialization) acknowledge and affirm the salience and significance of hearing loss in a way that should promote identification with the Deaf cultural group (i.e., Deaf acculturation). MSS was, in fact, strongly correlated with Deaf acculturation ($r=.70, p=.000$). These two findings demonstrate predictive validity.

Concurrent validity. Concurrent validity is evidenced by the ability of a measure to distinguish between groups. Socialization predicts cultural identity development, therefore the DCSS and MSS should be able to distinguish between cultural identity groups. It would be expected that individuals with Deaf or Bicultural identities would report having received more socialization (i.e., DCSS and MSS) than those with Marginal or Hearing identities.

The DCSS and the MSS both demonstrated concurrent validity in their ability to distinguish between the cultural identities. Table 11 presents a summary of ANOVA and post hoc contrasts of the DCSS and MSS across the four cultural identities. There was a significant main effect of cultural identity on DCSS with a large effect size (Welch $F=67.59, p=.000, \eta^2=.41$) and on MSS with a medium effect size (Welch $F=41.01, p=.000, \eta^2=.28$). Post hoc analyses indicated that participants with Marginal identities scored significantly lower on the DCSS and MSS than those with Deaf and Bicultural identities. Participants with Hearing identities also scored significantly lower on the DCSS and MSS than those with Deaf and Bicultural identities. There was no difference between those with Marginal and Hearing identities, nor between those with Deaf and Bicultural identities for either measure. (See Appendix K for additional analyses of cultural identity group differences in the other study variables.)

Table 11

Summary of Descriptive Results, ANOVA, and Post-Hoc Contrast Analyses of DCSS and MSS Across Cultural Identity Statuses

	N	M	SD	F	p	Post-Hoc Games-Howell ^a		
						Marginal	Hearing	Deaf
DCSS				67.59 ^a	.000**			
Marginal	32	2.16	.99					
Hearing	126	2.12	.94			.997		
Deaf	16	3.34	.58			.000**	.000**	
Bicultural	131	3.60	.83			.000**	.000**	.376
MSS				41.01 ^a	.000**			
Marginal	31	2.26	.94					
Hearing	126	2.65	1.19			.224		
Deaf	11	3.56	.65			.000**	.000**	
Bicultural	129	3.82	.85			.000**	.000**	.511

Note. ^aAssumption of homogeneity of variance is violated; Welch F and Games-Howell post hoc analyses are reported.

$p < .001$

Discriminant validity. Socialization is considered an aspect of positive parenting (Chakawa & Hoglund, 2016), but discriminant validity should demonstrate that the DCSS and MSS are measuring something unique and distinct from general positive parenting. Discriminant validity would be evidenced by a small negative correlation between the socialization measures (i.e., DCSS and MSS) and the measures of negative parenting included in the study (i.e., Remembered Relationships with Parents: Control and Alienation). Surprisingly, control had a small *positive* correlation with DCSS ($r = .24, p = .000$) and MSS ($r = .22, p = .000$). In other words, higher levels of socialization were associated with parents perceived as more controlling and overprotective. Alienation was uncorrelated with DCSS and MSS. In summary, the correlations between socialization and relationships with parents did not provide the expected evidence of discriminant validity. See discussion section for additional comments regarding the Remember Relationships with Parents Scale.

Discriminant validity could also be evaluated based on the correlation between the two measures of socialization (i.e., DCSS and MSS). The two socialization scales were strongly correlated with each other ($r = .86, p = .000$). A moderate to strong relationship was expected, as the scales measure two aspects of socialization regarding being deaf. While quite similar in their intent to socialize their child as a deaf person, the scales differ in that the DCSS promotes functioning in the Deaf arena, while the MSS promotes functioning in the hearing arena. The high degree of this correlation may indicate that the scales are measuring somewhat overlapping latent variables. This will be explored further in the discussion.

Descriptive Analyses

A thorough review of the descriptive characteristics of the study variables are presented to provide familiarity with the variables and their inter-relationships. To explore the validity of the assumption presented in the literature about the deterministic nature of parents' hearing status, each of the study's measured variables were compared across parents' hearing status. To provide a full understanding of engagement in socialization, DCSS and MSS scores were compared across sociodemographic characteristics. The association among study variables, and among the sociodemographic characteristics and the outcome variables are then presented to inform the hypothesis-testing analyses.

Acculturation. The Deaf Acculturation Scale consists of two culture scales (i.e., the Deaf Culture scale and the Hearing Culture scale) whose total scores are reported as Deaf acculturation and Hearing acculturation (see Table 12). The acculturation model suggests that orientations to the two distinct cultures (i.e., Deaf culture and Hearing culture) are independent of one another, in that orientation to one culture does not threaten orientation to the other (Maxwell-McCaw, 2001). This was supported in the current sample, in which there was a small

Table 12

Bivariate Correlations Among the Subscales of the Deaf Acculturation Scale- Deaf and Hearing Culture Scales and the DCSS and MSS

Scale	1	2	3	4	5	6	7	8	9	10	11	12
1. Deaf Acculturation (Total)	1	.77**	.88**	.81**	.89**	.85**	.12*	.17**	.23**	.00	.36**	.08
2. Deaf Cultural Identification	.77**	1	.70**	.46**	.62**	.59**	.18**	.25**	.27**	.05	.23**	.15**
3. Deaf Cultural Involvement	.88**	.70**	1	.61**	.72**	.66**	.11	.19**	.24**	-.03	.28**	.04
4. Deaf Cultural Preferences	.81**	.46**	.61**	1	.68**	.56**	-.03	.04	.08	-.04	.21**	-.05
5. Deaf Cultural Competence	.89**	.62**	.72**	.68**	1	.75**	.17**	.16**	.25**	.04	.38**	.11
6. Deaf Language Competence	.85**	.59**	.66**	.56**	.75**	1	.13*	.12*	.18**	.01	.40**	.12*
7. Hearing Acculturation (Total)	.12*	.18**	.11	-.03	.17**	.13*	1	.70**	.78**	.78**	.68**	.73**
8. Hearing Cultural Identity	.17**	.25**	.19**	.04	.16**	.12*	.70**	1	.49**	.54**	.38**	.53**
9. Hearing Cultural Involvement	.23**	.27**	.24**	.08	.25**	.18**	.78**	.49**	1	.51**	.55**	.47**
10. Hearing Cultural Preferences	.00	.05	-.03	-.04	.04	.01	.78**	.54**	.51**	1	.42**	.55**
11. Hearing Cultural Competence	.36**	.23**	.28**	.21**	.38**	.40**	.68**	.38**	.55**	.42**	1	.40**
12. Hearing Language Competence	.08	.15**	.04	-.05	.11	.12*	.73**	.53**	.47**	.55**	.40**	1
M	2.83	3.19	3.04	2.47	2.64	2.91	3.58	3.64	3.54	3.54	3.37	3.80
SD	.89	.92	1.10	1.01	1.15	1.12	.68	.80	.93	.89	.99	.80
DCSS	.80**	.65**	.72**	.57**	.77**	.66**	.15**	.10	.24**	.00	.27**	.00
MSS	.70**	.66**	.63**	.43**	.65**	.62**	.20**	.19**	.26**	.03	.23**	.09

Note. Pearson correlation coefficients are presented. Means are reported as scale averages rated on 5-point scales.

* $p < .05$; ** $p < .001$

positive correlation between Deaf acculturation and Hearing acculturation ($r=.12, p=.032$). The five subscales of the Deaf Culture scale were moderately to strongly correlated with each other ($r=.46-.89$), as were the Hearing Culture subscales ($r=.38-.55$).

Each of the Deaf Culture subscales was moderately to strongly correlated with the socialization measures (i.e., DCSS and MSS; see Table 12). Some of the Hearing Culture subscales had small correlations with the socialization measures.

Parents' hearing status and study variables. The literature review presented suggested that psychosocial outcomes likely differ for those with hearing and deaf parents. Table 13 presents a summary of analyses of variance exploring if the study variables differed based on parents' hearing status. The only variable with group differences was self-esteem ($F_{2, 302}=3.95, p=.020, \eta^2=.03$), but the effect size was small. Tukey post-hoc comparisons identified that those with no deaf or hard of hearing parents scored significantly higher than those with two or more deaf or hard of hearing parents on self-esteem (Mean Difference=.47, $SE=.17, p=.019$). Parents' hearing status was controlled for in the hypothesis-testing analyses below. (Alternatively, see Appendix L for results based on parents' hearing status dichotomized as hearing only versus one or more deaf or hard of hearing parents.)

Table 13
Summary of Analysis of Variance Results of Group Differences in Study Variables by Number of Deaf or Hard of Hearing (D/HH) Parents

	<i>M</i>	<i>SD</i>	<i>F</i>	<i>p</i>
DCSS			2.21	.111
0 D/HH Parents	2.75	1.16		
1 D/HH Parent	3.10	1.05		
2+ D/HH Parents	2.76	.98		
Total	2.82	1.14		
MSS			1.75	.176
0 D/HH Parents	3.09	1.19		
1 D/HH Parent	3.41	1.14		
2+ D/HH Parents	3.02	1.11		

Total	3.15	1.18		
Deaf Acculturation			2.02	.135
0 D/HH Parents	2.78	.91		
1 D/HH Parent	3.03	.84		
2+ D/HH Parents	2.89	.72		
Total	2.83	.89		
Hearing Acculturation			.87	.422
0 D/HH Parents	3.60	.68		
1 D/HH Parent	3.54	.68		
2+ D/HH Parents	3.33	.76		
Total	3.58	.68		
Self-Esteem			3.95	.020*
0 D/HH Parents	2.64 ^a	.55		
1 D/HH Parent	2.56	.47		
2+ D/HH Parents	2.17 ^a	.63		
Total	2.61	.54		
Satisfaction with Life			.30	.739
0 D/HH Parents	4.22	1.43		
1 D/HH Parent	4.30	1.33		
2+ D/HH Parents	3.94	1.38		
Total	4.23	1.40		
Depression/Anxiety			1.93	.147
0 D/HH Parents	2.47	.91		
1 D/HH Parent	2.45	.81		
2+ D/HH Parents	3.03	.78		
Total	2.49	.89		
Control			.59	.555
0 D/HH Parents	3.11	.91		
1 D/HH Parent	3.25	.87		
2+ D/HH Parents	3.18	.61		
Total	3.14	.89		
Alienation			.08	.920
0 D/HH Parents	3.00	1.04		
1 D/HH Parent	3.06	.99		
2+ D/HH Parents	3.02	.86		
Total	3.01	1.02		

Note. Sample sizes for levels of Parents' Hearing Status: 0 D/HH parents (n=234), 1 D/HH parent (n=61), 2+ D/HH parents (n=10). ^aSignificant group differences.

*p<.05

Differences in DCSS and MSS by sociodemographic characteristics. To fully describe engagement in socialization, scores on both the DCSS and MSS were evaluated for differences based on sociodemographic characteristics. Table 14 presents a summary of the

group means and differences. See Appendix M for detailed post hoc analyses of the group mean comparisons.

Table 14
Descriptive and ANOVA Summary of Means and Group Differences in DCSS and MSS Across Sociodemographic Characteristics

	N	DCSS				MSS			
		M	SD	F	p	M	SD	F	p
Gender				2.54	.081			.34	.712
Male	80	3.07	1.10			3.23	1.07		
Female	221	2.73	1.15			3.12	1.23		
Another	4	2.94	1.20			3.45	.87		
Total	305	2.82	1.14			3.15	1.18		
Ethnicity				.70 ^a	.627			.52	.758
White	173	2.74	1.21			3.07	1.24		
Asian/Asian American	26	2.81	1.06			3.08	1.05		
Hispanic/Latinx	38	2.80	.99			3.27	1.13		
Black/African Amer.	31	3.00	.97			3.30	1.02		
Amer. Indian/Alaska Native	4	2.98	.85			3.15	.91		
Multiracial or Other	33	3.11	1.21			3.35	1.22		
Total	305	2.82	1.14			3.15	1.18		
Majority/Minority ^b				2.18 ^a	.140			1.79	.181
White	173	2.74	1.21			3.07	1.24		
Non-White	132	2.93	1.05			3.26	1.10		
Total	305	2.82	1.14			3.15	1.18		
Education to Date				.82	.514			.98	.420
Did not complete H.S.	13	2.52	1.15			2.58	1.32		
In/graduated H.S.	94	2.82	1.16			3.16	1.22		
Some college	129	2.76	1.13			3.13	1.16		
Bachelor's degree	58	2.99	1.09			3.30	1.09		
Master's degree+	11	3.12	1.42			3.32	1.46		
Total	305	2.82	1.14			3.15	1.18		
Self-Label Choice				4.12	.003*			3.03	.018*
Hearing	22	3.06	1.11			3.01	1.14		
Deaf	35	3.47	.91			3.80	.86		
Hard of Hearing	190	2.75	1.12			3.09	1.18		
Hearing Impaired	54	2.57	1.22			3.07	1.28		
Other	4	2.51	1.26			2.60	1.19		

Total	305	2.82	1.14			3.15	1.18		
Degree of Hearing Loss				6.12	.000**			5.86	.000**
Mild	126	2.54	1.12			2.89	1.17		
Moderate	85	3.07	1.12			3.36	1.18		
Moderately Severe	46	3.39	1.06			3.71	1.02		
Severe	9	3.06	.98			3.04	1.00		
Profound	9	2.96	1.11			3.85	.96		
I do not know	30	2.37	1.03			2.65	1.11		
Total	305	2.82	1.14			3.15	1.18		
Age at Identification				6.48 ^a	.000**			4.89 ^a	.003*
0-1 years old	32	2.81	1.06			3.17	1.10		
2-3 years old	68	3.25	.99			3.54	1.06		
4-10 years old	89	2.90	1.07			3.23	1.07		
11+ years old	116	2.52	1.22			2.87	1.29		
Total	305	2.82	1.14			3.15	1.18		
Device Usage				29.55	.000**			22.84 ^a	.000**
None	116	2.24	1.03			2.62	1.20		
Hearing Aid	166	3.16	1.06			3.45	1.07		
Cochlear Implant	21	3.39	1.01			3.79	.82		
Total	303	2.83	1.14			3.16	1.19		
Parents' Hearing Status				2.21	.111			1.75	.176
Hearing parent(s) only	234	2.75	1.16			3.09	1.19		
One D/HH parent	61	3.10	1.05			3.41	1.14		
More than one D/HH parents	10	2.76	.98			3.02	1.11		
Total	305	2.82	1.14			3.15	1.18		
Parents Ability to Sign				54.16 ^a	.000**			35.05 ^a	.000**
No parents signed	168	2.32	1.10			2.72	1.18		
One parent signed	86	3.34	.87			3.54	.98		
More than one parent signed	51	3.62	.80			3.92	.87		
Total	305	2.82	1.14			3.15	1.18		
Family Composition- Growing up lived with:				1.66	.177			.56	.643
One parent	71	2.74	1.11			3.10	1.24		
Two parents in same house	189	2.90	1.14			3.21	1.16		
More than one parent in separate houses	26	2.60	1.06			2.97	1.16		

Other caregiver(s)	6	2.07	1.33			2.83	1.32		
Total	292	2.81	1.13			3.15	1.18		
Classroom Type				10.42 ^a	.000**			8.25 ^a	.000**
Mainstream/Inclusive	195	2.59	1.15			2.98	1.22		
Special Education	61	3.10	1.07			3.20	1.04		
D/HH classroom at local school	41	3.40	.86			3.77	.85		
School for the Deaf (day or residential)	8	3.51	1.26			3.85	1.50		
Total	305	2.82	1.14			3.15	1.18		
Language of Instruction				13.58 ^a	.000**			5.88 ^a	.003*
Spoken English	229	2.63	1.15			3.02	1.22		
Other spoken language	15	3.03	.80			3.17	.89		
American Sign Language	50	3.57	.94			3.70	.97		
Other sign language (e.g., SEE, TC, Cued)	11	3.19	.47			3.38			
Total	305	2.82	1.14			3.15			
D/HH Peers in Classroom				29.12 ^a	.000**			27.94 ^a	.000**
0	136	2.32	1.12			2.62	1.23		
1-5	148	3.19	1.00			3.58	.93		
More than 5	21	3.54	.91			3.61	1.12		
Total	305	2.82	1.14			3.15	1.18		

Note. DCSS and MSS means are reported as scale averages rated on a 5-point Likert scale.

^B Majority/Minority compares those who identified as White versus a combination of all other ethnic categories to explore if being minoritized based on race or ethnicity affected engagement in DCSS and MSS. ^aThe assumption of homogeneity of variance was violated; Welch F reported.

* $p < .05$; ** $p < .001$

Correlations between study variables. Table 15 presents the correlations between the study variables. The DCSS and MSS were strongly correlated with each other ($r = .86, p = .000$). These variables, therefore, were not entered into the hypothesis-testing hierarchical regressions simultaneously, as they would have introduced multicollinearity to the model. Relationship with parents (i.e., control and alienation) were correlated with the outcome variables and therefore were controlled for in the hypothesis-testing analyses.

The DCSS and MSS were both significantly correlated with most of the outcome variables as expected (i.e., Deaf acculturation, self-esteem, satisfaction with life). DCSS and MSS did not correlate with depression/anxiety, however. The correlations between socialization (i.e., DCSS and MSS) and Hearing acculturation, while small, were not expected (see Discussion chapter). However, it is worth noting that if the participants with the three lowest scores on Hearing acculturation (i.e., average scores of 1.00, 1.31, and 1.38) were omitted from the data set, the correlation would cease to be significant for DCSS ($r=.107, p=.063$). It would remain significant for MSS ($r=.53, p=.008$). Due to these preliminary correlational findings, self-esteem, satisfaction with life, and both Deaf and Hearing acculturation, but not depression/anxiety, were included as outcome variables in the hypothesis-testing analyses.

Table 15
Bivariate Correlations Among Study Variables

	1	2	3	4	5	6	7	8	9
1. DCSS	1								
2. MSS	.86**	1							
3. Deaf Accult.	.80**	.70**	1						
4. Hear. Accult.	.15**	.20**	.20**	1					
5. Self-Esteem	.23**	.21**	.16**	.12*	1				
6. Satisf. w Life	.38**	.29**	.32**	.26**	.57**	1			
7. Depress./Anx	-.02	-.03	.05	.08	-.54**	-.26**	1		
8. Control	.24**	.22**	.24**	.10	-.21**	-.04	.32**	1	
9. Alienation	-.00	-.01	.15*	.07	-.41**	-.22**	.48**	.58**	1
<i>M</i>	2.82	3.15	2.83	3.58	2.61	4.23	2.49	3.14	3.01
<i>SD</i>	1.14	1.18	.89	.68	.54	1.40	.89	.89	1.02

Note. Means are reported as scale averages on a 5-point Likert scale for the DCSS, the MSS, Deaf Acculturation, and Hearing Acculturation. Depression/Anxiety and Self-Esteem are averages on a 4-point scale. Satisfaction with Life is average on a 7-point scale.

* $p < .05$; ** $p < .001$

Sociodemographic characteristics and outcome variables. In order to identify relevant sociodemographic characteristics to control for in subsequent analyses, a series of simple linear regressions (see Table 16) were conducted with each of the sociodemographic characteristics regressed on each of the outcome variables that correlated with socialization (i.e.,

Deaf acculturation, Hearing acculturation, self-esteem, and satisfaction with life).

Depression/anxiety was not included in these analyses, as DCSS and MSS were not significantly correlated with depression/anxiety (see Table 15 above). Characteristics identified as significant predictors of outcome variables in Table 16 were considered for use as control variables in the hypothesis-testing analyses below.

Table 16
Summary of Simple Linear Regression Analyses Regressing the Sociodemographic Variables on the Outcome Variables

Sociodemographic	Deaf		Hearing		Self-Esteem		Satisfaction with Life	
	β	<i>p</i>	β	<i>p</i>	β	<i>p</i>	β	<i>p</i>
Gender ^a	-.14	.012*	.06	.299	-.05	.388	-.06	.334
Ethnicity ^b	.13	.020*	.06	.292	.07	.260	.03	.617
Education to Date ^c	.02	.710	.13	.027*	.15	.008*	.15	.008*
Self-label ^d	.16	.006*	-.06	.336	-.02	.778	.14	.014*
Degree of loss ^e	.29	.000**	.11	.062	.08	.151	.10	.073
Age at Identification ^f	-.20	.001*	.15	.009*	-.15	.008*	-.11	.056
Device Usage ^g	.29	.000**	.03	.651	.17	.003*	.20	.000**
Preferred Communication ^h	.29	.000**	-.05	.404	.02	.710	.10	.069
Do you know ASL? ⁱ	.55	.000**	-.13	.027*	.14	.013*	.11	.047*
Age of learning ASL ^j	-.24	.001*	-.08	.245	-.06	.388	-.27	.000**
English Literacy ^k	-.05	.384	.24	.000**	.05	.364	.09	.137
Parents' Hearing Status ^l	.10	.091	-.11	.061	-.14	.016*	-.01	.924
Parents' Ability to Sign ^m	.43	.000*	-.13	.028*	.20	.003*	.14	.014*
Family Composition ⁿ	-.04	.503	.02	.783	-.02	.751	-.06	.297
Classroom Type ^o	.26	.000**	-.21	.000**	.03	.668	.01	.840
Language of Instruction ^p	.29	.000**	-.21	.000**	.09	.135	.08	.181
D/HH Peers in Classroom ^q	.39	.000**	-.06	.322	.00	.980	.06	.292
School Composite	.40	.000**	-.20	.000**	.04	.502	.05	.349

Note. Standardized beta coefficients are presented. Standardized beta coefficients are presented. ^a 1=Male, 2=Female, 3=Another. ^b 1=White, 2=Asian/Asian American, 3= Hispanic/Latino, 4=Black/African American, 5=American Indian/Alaska Native, 6=Multiracial or Other. ^c 1=Did not complete high school (dropped out), 2=Currently enrolled/completed high school, 3=Some college, 4=Bachelor's degree, 5=Master's degree or higher. ^d 1=Hearing Impaired, 2=Hearing, 3=Hard of Hearing, 4=Deaf. ^e 1=Mild, 2=Moderate, 3=Moderately Severe, 4=Severe, 5=Profound. ^f 1=0-1 years old, 2=2-3 years old, 3=4-10 years old, 4=11+ years old. ^g 1=None, 2=Hearing aid(s), 3=Cochlear Implant(s), 4=Other. ^h 1=Oral/Aural, 2=Signed. ⁱ 1=No, 2=Yes. ^j 1=0-4 years old, 2=5-10 years old, 3=11-17 years old, 4=18+ years old. ^k 1=Low, 2=Medium, 3=High. ^l 1=Hearing parents only, 2=One

deaf or hard of hearing parent, 3= 2 or more deaf or hard of hearing parent(s). ^m 1=No parents can sign, 2=One parent can sign, 3= Two or more parent(s) can sign. ⁿ 1=One parent, 2=Two parents cohabitating, 3=More than one parent in separate houses, 4=Other caregiver(s). ^o 1=Mainstream/inclusive classroom, 2=Special education classroom, 3=Classroom for deaf and hard of hearing, 4=School for the deaf. ^p 1=Spoken English or spoken language, 3=American Sign Language, 4=Other signed language. ^q 1=0, 2=1-5, 3=More than 5. * $p < .05$; ** $p < .001$

Deaf Acculturation. The degree of Deaf acculturation was predicted by two demographic characteristics (i.e., gender and ethnicity), one family characteristic (i.e., parents' ability to sign), and each of the school characteristics. Deaf Acculturation was predicted by most of the hearing/language-related characteristics, including self-label, degree of loss, age at identification, device usage, preferred communication, knowledge of ASL, and age at learning ASL. However, self-label, preferred communication, knowledge of ASL, and age at learning ASL were excluded from the subsequent analysis because they are confounded with cultural identity (i.e., the outcome variable: Deaf Acculturation). The Deaf Acculturation Scale includes items that measure communication and self-identification (e.g., "I call myself deaf," and "How well do you sign using ASL?"). Therefore, gender, ethnicity, parent's ability to sign, degree of loss, age at identification, device usage and school composite score were used as control variables in the hypothesis testing analyses.

Hearing acculturation. The degree of Hearing acculturation was predicted by education to date, age at identification, knowledge of ASL (negatively), English literacy, parents' ability to sign (negatively), classroom type (negatively), and language of instruction (negatively). Again, knowledge of ASL was considered confounded with cultural identity and omitted from these analyses. Parents' ability to sign was considered confounded with their socialization practices and omitted from these analyses. The educational variables were again reflected in a composite score to avoid issues of multicollinearity. Therefore, education to date, age at identification,

English literacy, and school composite score were used as control variables in the hypothesis testing analyses.

Self-Esteem. Self-esteem was predicted by education to date, age at identification (negatively), device usage, knowledge of ASL, parents' hearing status (negatively), and parents' ability to sign. Parents' ability to sign is confounded with their socialization practices, so this variable was omitted from the hypothesis testing. Each of the other characteristics were used as control variables in the hypothesis testing analyses.

Satisfaction with Life. Satisfaction with life was predicted by education to date, self-label, device usage, knowledge of ASL, age of learning ASL (negatively), and parents' ability to sign. Age of learning ASL was omitted from the following analyses because it only applies to the portion of the sample that indicated that they knew ASL (N=203). Parents' ability to sign was omitted because it is confounded with their socialization practices. Therefore, education to date, self-label, device usage, and knowledge of ASL were used as control variables in the hypothesis testing analyses.

Research Question: How is Socialization Associated with Cultural Identity and Well-Being Outcomes?

The primary goal of this dissertation is to explore parents' socialization practices as a mechanism through which parents influence their child's cultural identity development and well-being. To do so thoroughly, a series of hierarchical regressions evaluated the degree to which socialization (i.e., DCSS or MSS) predicts cultural identity (i.e., Deaf Acculturation and Hearing Acculturation) and well-being (i.e., Self-Esteem and Satisfaction with Life) while controlling for

parents' hearing status, relationships with parents (i.e., RRPS: Control and Alienation), and the sociodemographic characteristics previously identified as relevant.

Preliminary analyses of the dependent variables evaluated if they satisfied the assumptions associated with using multiple linear regression, namely, linearity of residuals, independence of residuals, normal distribution of residuals, homoscedasticity and no multicollinearity. The Self-Esteem Scale, the Satisfaction with Life Scale, and the Hearing Scale of the Deaf Acculturation Scale all satisfied the assumptions. The Deaf Scale of the Deaf Acculturation Scale did not have normally distributed residuals (Shapiro-Wilks=.98, $p=.000$) and had mild issues with kurtosis (kurtosis=.98, $SE=.28$). There were no issues of skew (skew=.35, $SE=.14$), but there were several outliers. The outliers were meaningful (i.e., they were scores within the scale range and not the result of data entry errors) and retained accordingly. The PHQ-4 (i.e., measure of depression/anxiety) did not have normally distributed residuals (Shapiro-Wilks=.96, $p=.000$) and had mild issues with kurtosis (kurtosis=-.94, $SE=.28$). There were no issues of skew (.09, $SE=.14$) or outliers. These scales all satisfied the assumptions of linearity, independence, and homoscedasticity. Multicollinearity was assessed for each analysis and address in table notes.

The potential moderating effect of parents' hearing status was explored preliminarily to determine if the association between socialization and outcome variables varied based on parents' hearing status. To test this, a multiple regression analysis was done for each of the outcome variables with socialization (i.e., DCSS or MSS; See Appendix N), parents' hearing status, and a moderator term (i.e., centered, trichotomized parents' hearing status multiplied by centered DCSS or MSS) as predictors. Parents' hearing status did not moderate the association

between Deaf cultural socialization and any of the outcome variables. Parents' hearing status did moderate one association between minority status socialization and outcome variables (MSS $\beta=.22, p=.000$, parents' hearing status $\beta=-.15, p=.008$, Moderator term $\beta=-.12, p=.035$): MSS only predicted self-esteem for those with hearing parents ($\beta=.27, p=.000$). Increases in minority status socialization was not associated with increases in self-esteem for those with one ($\beta=.07, p=.588$) or two or more deaf or hard of hearing parents ($\beta=-.36, p=.311$).

The hypotheses were tested with hierarchical linear regressions for each of the identified outcome variables (i.e., Deaf acculturation, Hearing acculturation, self-esteem, and satisfaction with life). The sociodemographic variables identified as significant predictors of the outcome variable (see Table 16) were used as control variables (step 1). Based on the theoretical discussion in the literature review and the limited evidence of group differences in the current sample (i.e., differences in self-esteem; see Table 13), parents' hearing status was controlled (step 2). Based on the theoretical discussion in the literature review and the correlations with outcome variables (see Table 15), relationships with parents were controlled (step 3; i.e., control and alienation). Finally, socialization (i.e., DCSS or MSS, separately to avoid multicollinearity) was added as a fourth step. This conservative approach was selected because so many factors have been identified as predicting outcomes for deaf and hard of hearing individuals. By controlling as many as possible, these analyses aim to tease out the genuine effects of socialization.

The hypotheses were supported if the socialization term (i.e., DCSS or MSS) emerged as a significant predictor of the respective outcome variables after controlling for all other

characteristics and variables. The null hypothesis would be considered supported if the socialization term (i.e., DCSS or MSS) was not a significant predictor in the full model.

Hypothesis 1a: Socialization (i.e., DCSS or MSS) predicts cultural identity (i.e., Deaf acculturation). To test the ability of socialization to predict Deaf acculturation, a hierarchical regression (see Table 17) was conducted regressing DCSS or MSS, separately, on Deaf acculturation while controlling for sociodemographic characteristics (i.e., gender, ethnicity, degree of loss, age at identification, device usage, and school composite score) in step 1, parents' hearing status in step 2, and relationships with parents (i.e., control and alienation) in step 3.

After controlling for the relevant sociodemographic characteristics ($R^2=.241, p=.000$), adding parents' hearing status in Step 2 did not improve the model ($\Delta R^2=.001, p=.651$), but adding control and alienation in Step 3 did improve it ($\Delta R^2=.065, p=.000$).

Deaf cultural socialization and Deaf acculturation. When DCSS was added to the model in step 4a, the model was significantly improved ($\Delta R^2=.364, p=.000$; see Table 17). The full model (i.e., the model which included DCSS) was the best predictor of Deaf acculturation, explaining 67% of the variance. The effect size was large; Cohen's $f^2=2.03$ (i.e., $f^2>.35$ is a large effect; Cohen, 1988).

Minority status socialization and Deaf acculturation. When MSS was added to the model in step 4b, the model was significantly improved ($\Delta R^2=.264, p=.000$; see Table 17). The full model (i.e., the model which included MSS) was the best predictor of Deaf acculturation, explaining 57% of the variance. The effect size was large; Cohen's $f^2=1.33$.

Both DCSS and MSS were strong predictors of Deaf acculturation, while controlling for the relevant sociodemographic characteristics, parents' hearing status, and remembered relationships with parents. Alienating parenting, but not parents' hearing status contributed to the final models. For the MSS model, (i.e., Model 4b) Gender (i.e., males more Deaf acculturated) and School Composite score (i.e., the more Deaf-centered the school, the more Deaf acculturated) contributed significantly to the final model. DCSS and MSS were the strongest predictors in the respective models.

An online power calculator (<https://www.danielsoper.com/statcalc/calculator.aspx?id=17>) indicates that for a hierarchical regression with sample size $N=305$, nine control variables, 1 independent variable, $\alpha=.05$, with effect size of .203 and 1.33, the observed power for both models equals 1.0.

DCSS and MSS were not expected to predict Hearing acculturation. However, the variables were significantly correlated. Therefore, a hierarchical regression (see Table 18) was conducted to explore the association thoroughly. DCSS or MSS were regressed, separately, on Hearing acculturation while controlling for sociodemographic characteristics (i.e., education attained to date, age at identification, English literacy, and school composition) in Step 1, parents' hearing status in Step 2, and relationships with parents (i.e., control and alienation) in Step 3.

After controlling for the relevant sociodemographic characteristics ($R^2=.104$, $p=.000$), adding parents' hearing status in Step 2 did not significantly improve the model ($\Delta R^2=.00$, $p=.832$), nor did adding control and alienation in Step 3 ($\Delta R^2=.015$, $p=.082$).

Table 17

Summary of Hierarchical Regression Analysis Regressing DCSS or MSS on Deaf Acculturation (Steps 4a and 4b) While Controlling for Sociodemographic Variables (Step 1), Parents' Hearing Status (Step 2), and Remembered Relationships with Parents: Control and Alienation (Step 3)

Variable	Step 1		Step 2		Step 3		Step 4a: DCSS		Step 4b: MSS	
	B (SE)	β	B (SE)	β	B (SE)	β	B (SE)	β	B (SE)	β
Gender	-6.21 (2.9)	-.11*	-6.13 (2.9)	-.11*	-4.42 (2.8)	-.08	-2.71 (1.9)	-.05	-5.98 (2.2)	-.11*
Ethnicity	1.58 (.8)	.10*	1.58 (.8)	.10*	1.13 (.8)	.07	.58 (.5)	.04	.84 (.6)	.06
Degree Loss	-.56 (.9)	.03	.54 (.9)	.03	.85 (.8)	.05	.77 (.6)	.05	.89 (.7)	.05
Age at Iden.	-1.23 (1.4)	-.05	-1.18 (1.4)	-.05	-1.51 (1.4)	-.06	-1.43 (.9)	-.06	-1.30 (1.1)	-.05
Device Usage	9.63 (2.4)	.22**	9.62 (2.4)	.22**	10.90 (2.3)	.25**	.90 (1.7)	.02	3.39 (1.9)	.08
School Comp.	5.67 (.9)	.32**	5.63 (1.0)	.32**	5.18 (.9)	.30**	1.22 (.7)	.07	2.45 (.8)	.14*
PHS			1.18 (2.6)	.02	.58 (2.5)	.01	.27 (1.7)	.01	.48 (2.0)	.01
Control					1.29 (.4)	.22**	-.01 (.3)	.00	.23 (.3)	.04
Alienation					.29 (.3)	.06	.81 (.2)	.16**	.73 (.3)	.14*
DCSS							.84 (.1)	.74**		
MSS									2.62 (.2)	.60**
	R^2	.232		.241		.306		.670		.570
	F for ΔR^2	15.66**		.21		13.70**		322.29**		176.25**
	f^2	.317		.317		.441		2.030		1.326

Note. Multicollinearity was not problematic; VIF for Step 4a and 4b ranged from 1.03-1.78. * $p < .05$; ** $p < .001$

Deaf cultural socialization and Hearing acculturation. When DCSS was added to the model in step 4a, the model was significantly improved ($\Delta R^2=.041, p=000$). The full model (i.e., the model which included DCSS) was the best predictor of Hearing acculturation, explaining 16% of the variance. The effect size was moderate; Cohen's $f^2=.19$ (i.e., $f^2>.15$ is a moderate effect; Cohen, 1988).

Minority status socialization and Hearing acculturation. When MSS was added to the model in step 4b, the model was significantly improved ($\Delta R^2=.053, p=.000$). The full model (i.e., the model which included MSS) was the best predictor of Hearing acculturation, explaining 17.2% of the variance. The effect size was moderate; Cohen's $f^2=.21$.

Both DCSS and MSS predicted Hearing acculturation, while controlling for the relevant sociodemographic characteristics, parents' hearing status, and remembered relationships with parents. For both the DCSS model (i.e., Step 4a) and the MSS model (i.e., Step 4b), education to date, age at identification, English literacy, and school composite (negatively) were also significant contributors. DCSS and MSS were the strongest predictors in the models, respectively. Neither parenting qualities nor parents' hearing status contributed to the final models.

While only the association with Deaf acculturation was expected, Hearing acculturation was also predicted by socialization. However, the regression coefficients, proportion of variance explained, and effect sizes were much smaller for Hearing acculturation (i.e., Deaf acculturation $\beta=.74$ and $.60, R^2=.67$ and $.57$, Cohen's $f^2=2.03$ and 1.33 for the DCSS and MSS, respectively; Hearing acculturation $\beta=.23$ and $.26, R^2=.16$ and $.17$, Cohen's $f^2=.19$ and $.21$ for the DCSS and MSS, respectively).

Table 18

Summary of Hierarchical Regression Analysis Regressing DCSS or MSS on Hearing Acculturation (Steps 4a and 4b) While Controlling for Sociodemographic Variables (Step 1), Parents' Hearing Status (Step 2), and Remembered Relationships with Parents: Control and Alienation (Step 3)

Variable	Step 1		Step 2		Step 3		Step 4a: DCSS		Step 4b: MSS	
	B (SE)	β	B (SE)	β	B (SE)	β	B (SE)	β	B (SE)	β
Education to Date	.12 (.08)	.15*	.12 (.04)	.15*	.12 (.04)	.16*	.11 (.04)	.14*	.11 (.04)	.14*
Age at Ident.	.08 (.04)	.12*	.08 (.04)	.12*	.07 (.04)	.11	.09 (.04)	.13*	.09 (.04)	.13*
Eng. Literacy	.27 (.08)	.20**	.27 (.08)	.20*	.28 (.08)	.21**	.26 (.08)	.19*	.24 (.08)	.18*
School Comp.	-.04 (.03)	-.08	-.03 (.03)	-.08	-.04 (.03)	-.08	-.08 (.03)	-.17*	-.08 (.03)	-.17*
PHS			-.02 (.07)	-.01	-.02 (.07)	-.02	-.03 (.07)	-.02	-.03 (.07)	-.02
Control					.02 (.01)	.11	.01 (.01)	.04	.01 (.07)	.04
Alienation					.00 (.01)	.02	.01 (.01)	.05	.01 (.01)	.05
DCSS							.01 (.00)	.23**		
MSS									.03 (.01)	.26**
	R^2	.10		.10		.12		.16		.17
	F for ΔR^2	8.68**		.05		2.53		14.49**		18.62**
	f^2	.111		.111		.136		.190		.205

Note. Multicollinearity was not problematic; VIF for Step 4a and 4b ranged from 1.01-1.71. * $p < .05$; ** $p < .001$

Hypothesis 1b: Socialization (i.e., DCSS or MSS) predicts cultural identity (i.e., cultural identity status). To evaluate the association between socialization and cultural identity another way, the four cultural identity statuses (i.e., Marginal, Hearing, Deaf, and Bicultural) were used as the outcome variable.

Deaf cultural socialization and cultural identity status. A multinomial logistic regression was conducted with cultural identity status as a dependent variable and average Deaf cultural socialization as the predictor variable. The model was a good fit, with a likelihood ratio value of $\chi^2(3)=148.65, p=.000$ ($p<.05$ is desired; Bayaga, 2010). The Cox & Snell and Nagelkerke pseudo R^2 values are .386 and .432, respectively, so Deaf cultural socialization explains between 38.6-43.2% of the variability in cultural identity status (interpretation recommended in Bayaga, 2010).

As average Deaf cultural socialization increases by one unit, the odds of being categorized Deaf or Bicultural identity instead of Marginal increased by 3.72 and 5.41 times (see Table 19). As average Deaf cultural socialization increased by one unit, the odds of being categorized as Deaf or Bicultural identity instead of Hearing increased by 3.89 and 5.65 times, respectively. The odds of being categorized as Marginal versus Hearing (Wald=.04, $p=.833$) and Deaf versus Bicultural (Wald=1.47, $p=.226$) did not differ based on changes in Deaf cultural socialization.

Table # 19

Summary of Multinomial Logistic Regression Analysis with Deaf Cultural Socialization (DCSS) Regressed on the Cultural Identity Statuses

Reference	Comparison	B	SE	Wald	df	p	OR	Lower CI	Upper CI
Marginal	Hearing	-.05	.21	.04	1	.833	.956	.632	1.448

Marginal	Deaf	1.32	.36	13.52	1	.000**	3.724	1.848	7.507
Marginal	Bicultural	1.69	.26	43.47	1	.000**	5.407	3.274	8.930
Hearing	Deaf	1.36	.32	18.11	1	.000**	3.894	2.082	7.283
Hearing	Bicultural	1.73	.20	75.41	1	.000**	5.653	3.824	8.358
Deaf	Bicultural	.37	.31	1.47	1	.226	1.452	.794	2.654

Note. * $p < .05$; ** $p < .001$

Minority status socialization and cultural identity status. A multinomial logistic regression was conducted with cultural identity status as a dependent variables and average minority status socialization as the predictor variable. The model was a good fit, with a likelihood ratio value of $\chi^2(3)=94.92, p=.000$. The Cox & Snell and Nagelkerke pseudo R^2 values are .270 and .303, respectively, therefore, minority status socialization explains between 27 and 30.3% of the variability in cultural identity status.

As average minority status socialization increases by one unit, the odds of being categorized Deaf or Bicultural identity instead of Marginal identity increased by 3.14 and 4.23 times, respectively (see Table 20). As minority status socialization increased by one unit, the odds of being categorized with a Deaf identity or Bicultural identity instead of a Hearing identity increased by 2.25 and 3.04 times, respectively. The odds of being categorized with a Marginal identity versus a Hearing identity (Wald=3.03, $p=.082$) and a Deaf identity versus a Bicultural identity (Wald=1.11, $p=.293$) did not differ based on changes in minority status socialization.

Table # 20

Summary of Multinomial Logistic Regression Analysis with Minority Status Socialization (MSS) Regressed on the Cultural Identity Statuses

Reference	Comparison	B	SE	Wald	df	p	OR	Lower CI	Upper CI
Marginal	Hearing	.33	.19	3.03	1	.082	1.392	.959	2.020
Marginal	Deaf	1.14	.33	12.36	1	.000**	3.136	1.658	5.932

Marginal	Bicultural	1.44	.22	42.42	1	.000**	4.229	2.740	6.526
Hearing	Deaf	.81	.28	8.21	1	.004*	2.253	1.293	3.928
Hearing	Bicultural	1.11	.15	53.66	1	.000**	3.038	2.257	4.090
Deaf	Bicultural	.30	.28	1.11	1	.293	1.348	.772	2.354

Note. * $p < .05$; ** $p < .001$

In summary, Hypothesis 1a and 1b were supported. Both DCSS and MSS predicted Deaf acculturation and Hearing acculturation, while controlling for the relevant sociodemographic characteristics, parents' hearing status, and remembered relationships with parents.

Hypothesis 2: Socialization (i.e., DCSS or MSS) predicts self-esteem. To test the ability of socialization to predict self-esteem, a hierarchical regression (see Table 21) was conducted regressing DCSS and MSS, separately, on self-esteem while controlling for relevant sociodemographic characteristics (i.e., education attained to date, age at identification, device usage, and knowledge of ASL) in Step 1, parents' hearing status in Step 2, and remembered relationships with parents (i.e., control and alienation) in Step 3.

After controlling for the relevant sociodemographic characteristics ($R^2 = .063$, $p = .001$), adding parents' hearing status in Step 2 significantly improved the model ($\Delta R^2 = .023$, $p = .006$), as did adding control and alienation in Step 3 ($\Delta R^2 = .140$, $p = .000$).

Deaf cultural socialization and self-esteem. When DCSS was added to the model in step 4a, the model was significantly improved ($\Delta R^2 = .032$, $p = .000$). The full model (i.e., the

Table 21

Summary of Hierarchical Regression Analysis Regressing DCSS or MSS on Self-Esteem (Steps 4a and 4b) While Controlling for Sociodemographic Variables (Step 1), Parents' Hearing Status (Step 2), and Remembered Relationships with Parents: Control and Alienation (Step 3)

Variable	Step 1		Step 2		Step 3		Step 4a: DCSS		Step 4b: MSS	
	B (SE)	β	B (SE)	β	B (SE)	β	B (SE)	β	B (SE)	β
Education to Date	.07 (.04)	.12*	.07 (.03)	.12*	.06 (.03)	.09	.06 (.03)	.10	.06 (.03)	.09
Age at Ident.	-.06 (.03)	-.11	-.07 (.03)	-.12*	-.04 (.03)	-.07	-.03 (.03)	-.06	-.03 (.03)	-.06
Device Usage	.09 (.06)	.10	.10 (.06)	.11	.06 (.05)	.07	.01 (.05)	.01	.02 (.05)	.02
Know ASL	.09 (.07)	.08	.08 (.07)	.07	.10 (.06)	.09	.01 (.07)	.01	.04 (.07)	.04
PHS			-.16 (.06)	-.15*	-.15 (.06)	-.14*	-.16 (.05)	-.15*	-.16 (.05)	-.15*
Control					.01 (.01)	.04	-.00 (.01)	-.03	-.00 (.01)	-.01
Alienation					-.04 (.01)	-.41**	-.04 (.01)	-.38**	-.04 (.01)	-.38**
DCSS							.01 (.00)	.22**		
MSS									.02 (.01)	.18*
	R^2	.063		.086		.227		.259		.250
	F for ΔR^2	5.01*		7.57*		26.73**		12.87**		9.04*
	f^2	.067		.094		.294		.350		.333

Note. Multicollinearity was not problematic; VIF for Step 4a and 4b ranged from 1.02-1.73. * $p < .05$; ** $p < .001$

model which included DCSS) was the best predictor of self-esteem, explaining 25.9% of the variance. The effect size was large; Cohen's $f^2 = .35$.

Minority status socialization and self-esteem. When DCSS was added to the model in step 4b, the model was significantly improved ($\Delta R^2 = .023$, $p = .003$). The full model (i.e., the model which included MSS) was the best predictor of Self-Esteem, explaining 25% of the variance. The effect size was moderately-large; Cohen's $f^2 = .33$.

Hypothesis 2 was supported. Both DCSS and MSS predicted of Self-Esteem, while controlling for the relevant sociodemographic characteristics, parents' hearing status, and remembered relationships with parents. Both parents' hearing status (negatively) and alienating parenting (negatively) contributed to the final models.

An online power calculator (<https://www.danielsoper.com/statcalc/calculator.aspx?id=17>) indicates that for a hierarchical regression with sample size $N = 305$, seven control variables, 1 independent variable, $\alpha = .05$, with effect sizes of .35 and .33, the observed power for both models equals 1.0.

Hypothesis 3: Socialization (i.e., DCSS or MSS) predicts satisfaction with life. To test the ability of socialization to predict satisfaction with life, a hierarchical regression (see Table 22) was conducted regressing DCSS and MSS, separately, on satisfaction with life while controlling for sociodemographic characteristics (i.e., education attained to date, age at identification, device usage, and knowledge of ASL) in Step 1, parents' hearing status in Step 2, and relationships with parents (i.e., Control and Alienation) in Step 3.

Table 22

Summary of Hierarchical Regression Analysis Regressing DCSS or MSS on Satisfaction with Life (Step 4a and 4b) While Controlling for Sociodemographic Variables (Step 1), Parents' Hearing Status (Step 2), and Remembered Relationships with Parents: Control and Alienation (Step 3)

Variable	Step 1		Step 2		Step 3		Step 4a: DCSS		Step 4b: MSS	
	B (SE)	β	B (SE)	β	B (SE)	β	B (SE)	β	B (SE)	β
Education to Date	.18 (.09)	.12*	.18 (.09)	.11*	.16 (.09)	.10	.17 (.08)	.11*	.16 (.09)	.10
Age at Ident.	.18 (.09)	.12*	.19 (.09)	.12*	.18 (.09)	.12*	.12 (.08)	.08	.16 (.09)	.10
Device Usage	.35 (.14)	.15*	.35 (.14)	.15*	.30 (.14)	.13*	.04 (.14)	.02	.15 (.14)	.06
Know ASL	.16 (.18)	.05	.15 (.18)	.05	.12 (.18)	.04	-.32 (.18)	-.11	-.10 (.18)	-.03
PHS			-.10 (.16)	-.04	-.10 (.16)	-.04	-.15 (.15)	-.05	-.12 (.15)	-.04
Control					.04 (.02)	.14	.01 (.02)	.02	.02 (.02)	.07
Alienation					-.07 (.02)	-.27**	-.06 (.02)	-.22*	-.07 (.02)	-.24*
DCSS							.03 (.00)	.41**		
MSS									.06 (.02)	.25**
	R^2	.069		.071		.117		.224		.161
	F for ΔR^2	5.47**		.37		7.69*		39.78**		15.17**
	f^2	.074		.076		.133		.289		.192

Note. Multicollinearity was not problematic; VIF for Step 4a and 4b ranged from 1.04-1.73. * $p < .05$; ** $p < .001$

After controlling for the relevant sociodemographic characteristics ($R^2=.069, p=.000$), adding parents' hearing status in Step 2 did not improve the model ($\Delta R^2=.001, p=.542$), but adding control and alienation in Step 3 did improve it ($\Delta R^2=.047, p=.001$).

Deaf cultural socialization and satisfaction with life. When DCSS was added to the model in step 4a, the model was significantly improved ($\Delta R^2=.106, p=.000$). The full model (i.e., the model which included DCSS) was the best predictor of satisfaction with life, explaining 22.4% of the variance. The effect size was moderate; Cohen's $f^2=.29$.

Minority status socialization and satisfaction with life. When MSS was added to the model in step 4b, the model was significantly improved ($\Delta R^2=.044, p=.000$). The full model (i.e., the model which included MSS) was the best predictor of satisfaction with life, explaining 16.1% of the variance. The effect size was moderate; Cohen's $f^2=.19$.

Hypothesis 3 was supported. Both DCSS and MSS predicted satisfaction with life, while controlling for the relevant sociodemographic characteristics, parents' hearing status, and remembered relationships with parents. Alienating parenting contributed to the final models, while parents' hearing status did not. Education to date contributed to the final DCSS model (i.e., Step 4a).

An online power calculator (<https://www.danielsoper.com/statcalc/calculator.aspx?id=17>) indicates that for a hierarchical regression with sample size $N=305$, seven control variables, 1 independent variable, $\alpha=.05$, with effect sizes of .29 and .19, the observed power for both models equals 1.0.

Hypothesis 4: Socialization (i.e., DCSS or MSS) predicts depression/anxiety (negatively). The planned hierarchical analysis was not warranted for depression/anxiety, as this outcome variable was not correlated with DCSS or MSS (see Table 15). The null hypothesis is therefore accepted; socialization did not predict depression/anxiety in this sample.

Chapter 5

Discussion

This dissertation addressed a gap in the Deaf identity literature regarding the role of socialization as a mechanism through which parents influence their deaf or hard of hearing child's cultural identity development and well-being. To do so, the ethnic-racial socialization framework was used to develop the constructs and associated measures of Deaf cultural socialization and minority status socialization. This dissertation also challenged the assumption that cultural identity and well-being outcomes are determined by parents' hearing status, by introducing socialization as an alternative explanation for group differences presented in the literature review (e.g., Glickman & Carey, 1993; Maxwell-McCaw & Zea, 2011). To accomplish these objectives, this research explored how socialization is associated with cultural identity development and well-being outcomes in a sample of deaf and hard of hearing emerging adults recruited online via Qualtrics.

This final chapter will discuss and contextualize the study's results. Recruitment via an online panel aggregator, such as Qualtrics, is unusual in Deaf identity research. Therefore, the nature of the sample is first discussed for context before providing a brief summary of the results, analyses of the key findings, and implications of the study. Suggestions for future research building on this work are then discussed before presenting limitations of this dissertation.

The Sample

The interpretation and generalizability of this study's findings are limited by the uniqueness of the sample. Specifically, this study was unusual in its recruitment method, some

sociodemographic characteristics, and in cultural identity. The following is a discussion of this study's uniqueness to establish the associated limitations and specificity of the interpretation of the key findings.

Recruitment differences. This national sample was recruited atypically via an online consumer panel aggregator that target-invited consumers likely to be deaf or hard of hearing based on their consumer profiles. A more typical means of recruitment in Deaf cultural identity research is through flyers, emails, and website links distributed via college campuses with high deaf enrollment (e.g., Gallaudet University, RIT/NTID; e.g. McLaughlin, 2012; Wolf Craig, 2012)) or organizations that serve the Deaf population (e.g., the National Association of the Deaf; e.g., Maxwell-McCaw, 2001).

Both recruitment methods have inherent benefits and weaknesses. For example, samples recruited via Deaf organizations and schools allow for greater confidence in the authenticity of the participants and their honesty when self-identifying as being deaf or hard of hearing. Conversely, when recruiting online from the general population, the hearing status of participants cannot be confirmed.

Typical samples recruited from Deaf organizations may produce biased samples. They are collected from convenient, often region-specific locations (e.g., Gallaudet campus, state organization for the Deaf). Invitations to participate will only be received by those who are affiliated with Deaf-centric organizations. This practice may systematically exclude those with Marginal or Hearing identities who may not seek such affiliation. This marginalized portion of the deaf and hard of hearing population consistently omitted from research and may be different in meaningful ways relevant to cultural identity development that need to be explored further.

This Qualtrics sample should be free of such bias, as recruitment did not depend on Deaf-

centered organizations or schools. The extent to which this Qualtrics sample is affiliated with such organizations is not known. However, this sample's degree of involvement in the Deaf culture was lower than in Maxwell-McCaw's (2001) study, therefore, they may be less affiliated with Deaf colleges and Deaf-centric organizations.

It would be prudent in future research to combine data collected via online recruitment from the general population and via more traditional methods to establish empirically the extent to which these sampling techniques differ, overlap, and engender bias. Ultimately, the difference in recruitment methodology underscores the need for additional validation studies to replicate these key findings and the psychometric properties of the new scales.

Sociodemographic differences. The present sample differed from previous samples and may be somewhat non-representative of the population, particularly in education experiences and variables related to hearing loss.

Education. The Qualtrics sample was educated primarily in mainstream school settings, with very few having attended Deaf schools. The low proportion of Deaf school attendance likely reflects the modern trend toward mainstream school settings, but future research could target recruit more students from Deaf schools to determine the extent to which these findings based on a mainstreamed sample generalize to those with Deaf school experiences. The role of parents may be different for those raised in more culturally Deaf school environments.

Studies that recruit via Deaf colleges (e.g., McLaughlin, 2012; Wolf Craig, 2012) include college educated participants, exclusively. This Qualtrics sample circumvented this systematic bias, with 35% of the sample reporting no college experience. Thus, this Qualtrics study

captured a wider variety of educational experiences that may be meaningful to psychosocial development.

“Less deaf.” The present sample is “less deaf” than other studies reviewed (Gallaudet Research Institute, 2011; Maxwell-McCaw, 2001; Wolf Craig, 2012), as indicated by self-label, degree of hearing loss, and age of identification of hearing loss. In the present sample, an unusually small proportion self-labeled as *deaf*, preferring *hard of hearing* and *hearing impaired*. Therefore, this sample may be more likely to hold the mainstream’s medical, rather than cultural model of being deaf, which is characteristic of Hearing and Marginal cultural identities. This Qualtrics sample’s hearing loss was also identified later in life than the comparison samples, which Glickman (1993) theorized was associated with more Hearing identification.

An unusually high rate reported Mild and Moderate hearing loss (69%), while the GRI data set reported 40% in this range. However, Maxwell-McCaw (2001) and Wolf Craig (2012) reported only 6.5% and 17.1%, respectively. These studies’ low proportion compared with the GRI data set demonstrates how studies recruited via Deaf-centric organizations and universities may be systematically underrepresenting a subpopulation that is “less deaf,” audiolgically and/or culturally, while the Qualtrics sample seems to overrepresent it. These instances of over- and under-representing subpopulations again underscores the need for replication of these findings with other samples. It also highlights this study’s strength, in that it better captures an underrepresented and marginalized subpopulation.

Cultural identity differences. The present sample also differed from previous studies in cultural identity status proportions. The current sample had an unusually high proportion of Hearing-identified and low proportion of Deaf-identified participants. The majority of the

sample were classified as a cultural identity status high in Hearing acculturation (Hearing or Bicultural). This finding is consistent with the theories that suggest that sociodemographic characteristics, such as high degree of mainstream education and low degree of hearing loss, predict cultural identity outcomes (e.g., Bat-Chava, 2000; Chen, 2014).

Such a mainstreamed, Hearing-oriented sample of emerging adults may have had little or no contact with the Deaf community yet (Glickman, 1993; Holcomb, 1997). They may be functioning and communicating well in hearing environments. Lacking the catalyst of positive exposure to cultural models or negative experiences with discrimination or communication barriers that tend to spur identity exploration (Glickman, 1993; Neblett et al., 2009; Ohna, 2004; Phinney, 1989), this sample may have not yet begun, or may never begin, a Deaf cultural identity development journey. This may explain the low rate of Deaf identity.

In summary, this sample's recruitment was unorthodox, and subsequently produced a unique sample. Compared to a large data set and two typically recruited samples, this sample had less severe hearing loss, less frequently self-labeled as *d/Deaf*, less frequently attended a Deaf school, reported their hearing loss was identified later in life, and had proportions of Deaf and hearing identity that were markedly different from comparison samples.

These differences are not inherently negative, nor do they diminish the findings of this study. Traditional methods of recruitment target convenient samples via Deaf-centric organizations and colleges, which may systematically underrepresent a subpopulation that is "less deaf," audilogically and/or culturally, which challenges the generalizability of traditional samples. Recruiting from the national general population with online random sampling may avoid this bias and access marginalized subpopulations in addition to more traditional subsets, thereby obtaining a more diverse sample from the deaf and hard of hearing population.

The key findings presented below must be interpreted solely within the scope of this unique sample. Additional validation studies are required with both Qualtrics and traditional recruitment methodology before generalizing these findings. However, parental engagement in Deaf cultural socialization may prove particularly meaningful within the contexts of family and school environments otherwise low in Deaf culture.

Summary of Results

Overall, Deaf cultural socialization and minority status socialization were strong predictors of psychosocial outcomes; better predictors than parents' hearing status.

Socialization predicted cultural identity and well-being outcomes. Both Deaf cultural socialization and minority status socialization were strong predictors of cultural identity (i.e., Deaf acculturation, Hearing acculturation, and cultural identity status) and self-esteem and satisfaction with life, but not depression/anxiety. Overall, socialization predicted cultural identity better than sociodemographic variables, parents' hearing status, and quality of relationship with parents. This finding demonstrates that parents play a significant role in their child's cultural identity development that parallels that of parents from other culturally marginalized groups through the process of socialization (e.g., Hughes et al., 2006; Neblett et al., 2009; Umaña-Taylor & Fine, 2004).

It is particularly compelling to note that socialization was such a strong predictor of cultural identity and well-being for such a Hearing-oriented sample. Even though this sample was "less Deaf" than traditional samples, or perhaps especially because it was so, messages from parents had strong associations with cultural development, self-esteem, and satisfaction with life,

regardless of relevant sociodemographic and family characteristics. Parents' efforts to introduce the Deaf culture to environments presumably low in Deaf culture (e.g., hearing families, mainstream schools) were beneficial for psychosocial outcomes.

Parents' Hearing Status was a poor predictor of outcomes. Parents' hearing status was not a significant predictor of cultural identity (i.e., Deaf acculturation, Hearing acculturation, and cultural identity status), satisfaction with life, or depression/anxiety. Parents' hearing status only predicted self-esteem. This finding firmly challenges the assumption in the literature that suggests that parents' hearing status determines psychosocial outcomes such as cultural identity and well-being (Bat-Chava, 2000; Glickman, 1993).

Analysis of Key Findings

The results culminate in two key findings concerning the role of parents in Deaf cultural identity development and the utility of the application of the ethnic-racial socialization model.

The role of parents in Deaf cultural identity development: agents of socialization.

This dissertation challenged the *parents' hearing status hypothesis*, which suggests that cultural identity and well-being outcomes are determined by parents' hearing status, and introduced the alternative *socialization hypothesis* as a mechanism by which parents influence their children's development.

The most significant way in which parent characteristics predicted the cultural identity and well-being of deaf and hard of hearing emerging adults was through their socialization practices. Parents' hearing status and remembered relationships with parents contributed to a much lesser extent, if at all.

Parents as agents of socialization. Parents played a significant role in their children's development through their role as agents of socialization. Parental engagement in both Deaf cultural socialization and minority status socialization were strong predictors of cultural identity, self-esteem, and satisfaction with life.

The finding that socialization promoted Deaf cultural identity development was expected based on social identity theory (Tajfel, 1981; 1982) and the ethnic-racial socialization framework (e.g., Brown & Krishnakumar, 2007; Grusec & Davidov, 2010b; Hughes et al., 2006; Umaña-Taylor et al., 2004b). The more parents say and do to teach their children about the importance and meaning of Deaf culture (Deaf cultural socialization), the more their children identify with, are involved with, prefer, and develop competences in Deaf culture (aspects of Deaf cultural identity). Similarly, parents' messages that prepared their children for success despite the ramifications of being deaf in a hearing society, such as equipping them to deal with discrimination and teaching them about their rights (minority status socialization), also promote these aspects of Deaf cultural identity.

The association between socialization and Hearing acculturation was unanticipated. However, it is reasonable that messages that teach children how to be successful as a deaf person in a hearing society (minority status socialization), such as teaching children to stand up for their accessibility needs, may reduce barriers to functioning in a hearing school or work environment. This functioning, in turn, might promote identification, competence, and preferences for the Hearing culture (Hearing acculturation). It is less clear why parents' messages about the importance and meaning of Deaf culture (Deaf cultural socialization) would be associated with increases in Hearing acculturation. This is discussed further in Future Research: Hearing acculturation.

Socialization predicted outcomes, regardless of parents' hearing status. It is important to note that the majority of parents in this study were hearing parents of Hearing-oriented children. Despite this, those with hearing parents reported receiving an equal degree of socialization as those with deaf parents. The predictive associations were equivalent across parent hearing status groups between Deaf cultural socialization and all the psychosocial outcomes, and between minority socialization status and all outcomes except self-esteem (see Appendix N).

Hearing parents' engagement in Deaf cultural socialization is beneficial. This hearing-oriented sample powerfully demonstrated the significance of parental socialization, regardless of parents' hearing status. These results suggest that Hearing-identified individuals, from hearing families and hearing schools, who may be functioning and communicating well within Hearing society still reap benefits from receiving socialization related to being deaf or hard of hearing. This finding is similar to that of transculturally adoptive families, in which children's birth culture identity development is beneficial even though parents do not share the culture and the children are not embedded within the birth culture (e.g., Lee et al., 2006).

This finding provides an important rebuttal to the literature that suggested that hearing parents do not support Deaf cultural identity development (e.g., Bat-Chava, 2000; Glickman, 1993). Despite the influence of messages received from medical professionals, the mainstream medical view of being deaf, and the preference for speech and functioning in the hearing world that has been found among hearing parents (e.g., Decker et al., 2012; Hardonk et al., 2010; Li et al., 2003), the hearing parents in this sample engaged in efforts equal to those with deaf parents to add the Deaf culture to their child's life through verbal and nonverbal socialization efforts.

Parents' hearing status as a predictor. The parents' hearing status hypothesis was not supported by this study with this Hearing-oriented sample. Parents' hearing status was a poor

predictor of cultural identity and well-being outcomes. Parents' hearing status only predicted self-esteem, though socialization was a stronger predictor.

Parents' hearing status as a moderator. Generally, parents' hearing status was not associated with differences in the relationships between socialization and psychosocial outcomes. Regardless of whether the agents of socialization were hearing, deaf, or deaf-hearing dyads, socialization predicted cultural identity and wellbeing.

Parents' hearing status only moderated one association between socialization and outcomes. Though there were no differences in the degree of minority status socialization, minority status socialization only predicted self-esteem for those with hearing parents. (See Future Research: Moderation and Appendix N).

Quality of the remembered relationships with parents. The qualities of the remembered relationship with parents demonstrated nuanced associations with the study variables. Socialization was considered an indicator of positive parenting but, surprisingly, was not negatively correlated with the indicators of "negative parenting." (See Future Research: Relationship with parents and Child perceptions of socialization).

Alienating relationships with parents predicted psychosocial outcomes. Intuitively, negative parenting predicted negative well-being. In the full regression models, alienation predicted lower self-esteem and lower satisfaction with life. Less intuitively, the more alienating the relationship with parents, the more the individual was acculturated to the Deaf culture (an outcome expected to be predicted by positive parenting [i.e., socialization]). Considering this sample's high degree hearing contexts (e.g., hearing families, hearing schools), alienating parenting may be indicator of marginalization within the family that may spur interest in finding

a community elsewhere; a new “family” of their choosing (e.g., within the Deaf community). Controlling parenting was correlated with socialization and outcomes but did not contribute to any full models (See Future Research: Relationship with parents.).

In summary, when it comes to the well-being and cultural identity outcomes of this sample of deaf and hard of hearing emerging adults, socialization is a better predictor than parents’ hearing status. This calls for a change from the focus on group differences based on parents’ hearing status toward the understanding of adoptable, beneficial parenting practices. Rather than discount hearing parents’ intentions, abilities, and efforts to promote positive outcomes, medical, educational, social service, and research professionals should increase their efforts to understand and support parents in their efforts to act as agents of socialization of an unshared culture.

The ethnic-racial socialization literature applies to Deaf cultural identity. This dissertation applied the ethnic-racial socialization model to Deaf cultural identity development to determine if patterns between socialization and psychosocial outcomes generalized to the deaf and hard of hearing community.

Ethnic-racial framework: Deaf cultural socialization predicts Deaf cultural identity development. As the ethnic-racial socialization framework suggests (e.g., Hughes et al., 2006; Lesane-Brown, 2006), cultural socialization predicted cultural identity and well-being outcomes for this sample of deaf and hard of hearing emerging adults. Both Deaf cultural socialization and minority status socialization predicted the degree of Deaf acculturation and the likelihood of being categorized as one of the two cultural identity statuses associated with high orientation to the Deaf culture (i.e., Deaf and Bicultural identity). These findings are consistent with the

ethnic-racial literature that demonstrates that cultural socialization regarding an ethnic culture predicts ethnic identity development (Hughes et al., 2006; Umaña-Taylor et al., 2004b).

The ethnic-racial model is relevant, well-suited, and useful for understanding Deaf cultural identity. This dissertation successfully applied the ethnic-racial socialization framework to the Deaf culture, which provides empirical support for the recognition of a Deaf ethnic group (Ladd & Lane, 2013). Using an established measure of ethnic socialization, the associations between ethnic-racial socialization and ethnic-racial identity development generalized to Deaf cultural socialization and Deaf cultural identity. In doing so, this dissertation takes a step toward establishing that the model of ethnic-racial socialization can elucidate the nuances of the role of parents in Deaf cultural identity development.

Multicultural family framework: Hearing parents engage in unshared cultural socialization, which predicts psychosocial outcomes. This dissertation suggested that hearing parents of deaf and hard of hearing children can be compared to majority member parents from multicultural families, such as transracially adoptive parents, who commonly engage in cultural socialization of the child's birth culture (Lee et al., 2006).

Like transracial adoption parents, hearing parents in this sample engaged in socialization regarding an unshared culture. Approximately 77% of this sample had no deaf or hard of hearing parents. Yet those with hearing parents reported receiving an equal degree of Deaf cultural socialization and minority status socialization as those with deaf and hard of hearing parents.

Generally, hearing parents' socialization messages are just as predictive of cultural identity and well-being outcomes as deaf parents' messages. Parents' hearing status only moderated the association between MSS and self-esteem. Socialization, even when the culture was unshared, predicted outcomes.

Whether the cultural differences within a family are based on ethnicity, race, nation of origin, language, or hearing status, parents can and do promote positive identity development of an unshared culture through unshared cultural socialization.

This dissertation takes a step toward establishing that the constructs and relationships from the multicultural family literature can be used to understand the role of parents as agents of unshared cultural socialization promoting Deaf cultural identity development within the context of a hearing family.

Deaf cultural identity and developmental research. This study is not unique in demonstrating that established developmental frameworks can be applied to the Deaf cultural group. The Deaf identity theories presented in the literature review were built upon social identity theory and the foundations of the ethnic-racial identity and immigrant acculturation frameworks (Glickman, 1993; Maxwell-McCaw, 2001).

Despite this background, much of the Deaf identity literature has developed in a pocket and been published in Deaf studies journals (e.g., *The American Annals of the Deaf*, *the Journal of Deaf Studies and Deaf Education*), which, while respected journals, may be largely overlooked by the mainstream developmental field. Deaf cultural identity research could dovetail to a larger degree with the larger fields of cultural and developmental psychology. The more established and elaborated theories, models, and measures of developmental psychology

could enhance the study of Deaf identity development, while introducing the similarities, differences, and strengths of this unique cultural group to the larger developmental field. This increased contact between the distinct research cultures could elicit a group-level acculturation that would benefit both research communities and the development of a more nuanced understanding of the Deaf cultural community.

Contributions and Implications

This dissertation makes several contributions to the fields of Deaf cultural identity research, early hearing loss interventions, and developmental psychology (i.e., cultural and ethnic-racial fields).

Challenging the parents' hearing status hypothesis. First, it challenged a pessimistic assumption found in the literature (i.e., parents' hearing status hypothesis) and suggested and supported an alternative hypothesis (i.e., socialization hypothesis). This is significant because the literature's focus on parents' unchangeable hearing status underestimated parental variability and parents' motivations, efforts, and abilities to promote Deaf cultural identity development. Parents do play a major role, but it is through what they say and do, not solely through their hearing status.

Parents, deaf and hearing alike, can choose to intentionally engage in Deaf cultural socialization. Their efforts to model participation and involvement, their conversations with their children, and the cultural experiences to which they expose their children make a difference in cultural identity and well-being outcomes. The role of parents is not passive or biologically determined. It is active, protective, voluntary, and can be therefore be learned and promoted

among parents and professionals working with deaf and hard of hearing youth. Rather than discounting hearing parents' intentions, abilities, and efforts to promote positive outcomes, researchers and early hearing loss interventionist (e.g., medical, speech/language, educational, and social service professionals) can educate and support parents in their efforts to act as agents of socialization of an unshared culture.

The parents' hearing status hypothesis may have been more applicable in the past, but may be decreasingly so in modern contexts. Societal advancements and shifts in historical contexts may have recently facilitated parents to take on a bigger as agents of socialization. The decline in prevalence of Deaf schools may have instigated a transition of the responsibility of socializing children into the Deaf culture from peers and mentors at Deaf schools to parents. Improvements in technology and interventions may be enabling better communication between parents and children, facilitating more sophisticated conversations about being deaf. The United States is increasingly multicultural and diversity is somewhat more accepted, which may lead to more culturally sensitive parenting. Internet access and community resources may provide greater access to sign language skills training, information on Deaf culture and history, access to social networks with other families with deaf children, and access to members of the Deaf community than ever before. These recent advancements and evolutions may enable parents to engage in cultural socialization practices more than ever before.

Applying and demonstrating the utility of the ethnic-racial socialization model. As a second contribution, this dissertation identified a gap in the literature and began to address it by effectively applying the ethnic-racial socialization literature to begin to understand the role of parents as agents of socialization in Deaf cultural identity development. Specifically, it

introduced new constructs and associated measures of socialization regarding being deaf. The constructs and associated measures are similar, yet different. Both socialization constructs and scales are concerned with the messages that parents transmit to their children regarding being deaf. Deaf cultural socialization promotes functioning in the Deaf cultural community, while minority status socialization promotes functioning in the Hearing cultural community. Therefore, they may predict cultural outcomes differentially, as Deaf cultural socialization may promote comfort with the Deaf community and the minority socialization may promote comfort with hearing society by reducing barriers. These constructs enable important first steps in understanding Deaf cultural identity development through the lens of ethnic-racial socialization.

Developing a measure of Deaf cultural socialization. Measures of socialization were needed to begin to understand the role of parents in Deaf cultural identity development. The DCSS and the MSS demonstrated strong reliability and predictive and concurrent validity. They make unique contributions to research. The DCSS may be more useful in studies of cultural identity development, such as exploration of and commitment to Deaf cultural values, pride, cultural engagement, and sense of belonging. The MSS (with further development) may be more useful in studies of coping with ability differences, bicultural competence, and functioning in hearing-dominated environment, such as school and work. More work is needed to develop and validate these measures, but this dissertation took an important first step in operationalizing these new constructs for empirical exploration.

Unique sample. This study used a unique sample recruited atypically that enabled exploration of potentially marginalized subsets of the deaf and hard of hearing population. This sample was more Hearing-oriented than typical samples, and despite this or perhaps because of

this, parents' efforts to socialization their children strongly predicted their cultural identity and well-being outcomes. This indicates that even in hearing families, where a child may be thriving in hearing society with cochlear implants, spoken language, and mainstream schooling, it is still important to embrace the Deaf culture to promote positive outcomes. Professionals who work with deaf and hard of hearing youth could apply these findings to better tailor services to support hearing parents as they raise culturally different children.

Future research

Given the gap in the literature regarding the role of parents as agents of socialization regarding the Deaf culture, the list of potential future research is lengthy. Several next steps will be outlined here. This dissertation ultimately asked: Does socialization matter? The answer is a resounding: Yes. There are many questions to ask next.

Sampling. The present sample was unique in terms of recruitment, sociodemographic characteristics, and cultural identity. Socialization should be explored with less Hearing-oriented samples to see if the findings generalize. Additional research is needed with a variety of recruitment techniques to replicate and validate these findings. Subsequent work that recruits with both Qualtrics and Deaf-centric organizations can explore the validity, distinctness, and commonalities produced by the two sampling methods.

Measurement. The constructs and measures introduced in this dissertation are in their preliminary development stage and require additional refinement and validation with other samples.

The Minority Status Socialization Scale. The MSS was an unintended byproduct of the DCSS scale development and requires considerable further development and analysis of content

and psychometric properties. Review of the content of the MSS items compared to the racial socialization literature reveal that two of the items could be classified as *preparation for bias*. One item could be classified as *promotion of mistrust*. The remaining three MSS items could be classified as *advocacy*. Advocacy is not a content area found in the racial socialization literature. These items were created based on the interview study with hearing mothers (Husting, 2018). While not in the racial socialization operationalizations, these items relate to the need to address their hearing difference and assert themselves for their rights and needs, which reflects another dimension of how parents prepare their child for challenges they may face based on their marginalized status as a member of a minoritized group.

Promotion of mistrust should not be included in a measure with preparation for bias and advocacy. The single promotion of mistrust item did not load well with the other factors. This likely relates to the fact that preparation for bias and advocacy items contain an element of coping, managing, or adapting to the environment (e.g., the discrimination, oppression, environmental challenge), while the promotion of mistrust item creates an expectation of discrimination/prejudice without providing a means of dealing with it. While moderate amounts of preparation can be protective, promotion of mistrust has been linked to negative outcomes (Wang et al., 2019). For example, Liu and Lau (2013) found promotion of mistrust to be negatively correlated with optimism and positively correlated with pessimism and depression symptoms. While promotion of mistrust and preparation for bias were correlated with each other and depression, preparation for bias was uncorrelated with optimism and pessimism. (See Appendix O for exploration of the distinct content classifications and study variables.) Additional item and scale development is needed on the MSS.

The Deaf Cultural Socialization Scale. The current factor analyses did not support treating verbal and nonverbal aspects of Deaf cultural socialization as separate scales. This lack of support of the two-factor model may not be specific to the present sample. While the a preliminary 8-item Family Ethnic Socialization Measure (FESM; Umaña-Taylor & Fine, 2004) identified a two-factor structure, subsequent work with the revised 12-item FESM reports total FESM, rather than using the Overt/Covert subscales. A. J. Umaña-Taylor (personal communication, May 29, 2019) indicated that she has not published factor analyses demonstrating the utility of the two-factor structure with the 12-item measure.

The distinction between what parents say and what they do may be meaningful with other samples or with modification to the DCSS. The modes of transmission should be further explored in subsequent studies to identify more specifically which aspects of socialization are beneficial. A preliminary exploration of Verbal and Nonverbal DCSS subscales (see Appendix J) seems to suggest that the influence of verbal and nonverbal messages may vary based on parents' hearing status. Additional research could tease apart differences in the influence of verbal and nonverbal expression modalities based on parents' hearing status and potentially other parent, child, or contextual factors.

Additionally, separate versions of the DCSS may need to be developed for those with deaf parents and those with hearing parents, as the intent behind the nonverbal socialization behaviors may be quite different and important to understand. Parental modeling of involvement in the Deaf culture may be a natural part of a deaf parents' daily life, as they express their own culture. For hearing parents, such modeling may be an intentional attempt to transmit an

unshared culture. These differences in intention are not captured in the current version of the DCSS.

Hearing acculturation. Unexpectedly, the two measures of socialization were associated with increases in Hearing acculturation. Future research could explore if this was an artifact of error in the emerging measures. Appendix P identifies that the correlation between Hearing acculturation and socialization is specific to the verbal Deaf-specific items. These items may need to be edited or omitted.

Alternatively, these results may relate to the high degree of Hearing-orientation within the current sample. It may also be a replicable finding, demonstrating that socialization promotes bicultural identity development. This requires additional investigation.

Moderation. Parents' hearing status only moderated one association between socialization and outcomes. Though there were no differences in the degree of minority status socialization, minority status socialization only predicted self-esteem for those with hearing parents. It is not yet clear why parents' efforts to prepare their child for discrimination and self-advocacy (minority status socialization) would only be beneficial when the parents are hearing. Additional research is required to see why parents' out-group status might attenuate the benefits of this type of socialization.

Socialization and positive parenting. Socialization is an aspect of positive parenting (e.g., Chakawa & Hoglund, 2016). However, socialization was not associated with positive parenting in this study. Additional exploration of indicators of positive parenting is warranted to evaluate this further.

Relationship with parents. Alienating relationships with parents predicted psychosocial outcomes. Intuitively, negative parenting predicted negative well-being. Less intuitively, the more alienating the relationship with parents, the more the individual was acculturated to the Deaf culture. Deaf acculturation is here assumed to be a positive outcome that is promoted by positive parenting (socialization). However, it may be that negative, alienating parenting may be an indicator of marginalization within the family that may drive the children away into a new Deaf “family” of their choosing. Increases in controlling parenting (an indicator of negative parenting) were associated with increases in socialization (an indicator of positive parenting), which in turn, was associated with higher Deaf acculturation. It may be that both negative and positive relationships with parents could, in their own way, promote Deaf cultural identity development. Negative parenting may reactively elicit search and exploration of the Deaf culture as individuals look for a place to belong and feel accepted. This should be explored further.

Additional measures of relationship with parents that have been validated on or developed for the deaf population that capture significant experiences associated with growing up deaf, such as feeling accepted or not having access to a full shared language with parents should be used in future studies.

Child perception of socialization. Socialization, while conceptualized as an aspect of positive parenting, was correlated with controlling parenting (e.g., parenting perceived as overprotective, sheltering, worried, and anxious for the child and their ability to take care of themselves). This begs the question: How do deaf and hard of hearing youths perceive their parents’ engagement in socialization? A qualitative study could explore how youths interpret their parents’ messages, such as supportive and accepting or as controlling. The child’s

perception may vary based on the frequency and timing of such messages and whether messages were delivered unprovoked or in response to experiences, such as being discriminated against.

Antecedents of socialization. Not all parents socialized their children regarding what it means to be deaf. Given the significance of socialization in predicting associated outcomes, it is important to understand why some parents do not engage in socialization. Research should explore the factors that predict socialization, such as those identified as predicting ethnic-racial socialization (e.g., parents' age, education, marital status, socio-economic status, color-blind attitudes, geographic location, and urbanicity; e.g., Hughes et al., 2006; Lesane-Brown, 2006) and those that may be specific to parents of deaf and hard of hearing parents (e.g., messages from medical professionals, salience and acceptance of child's hearing loss, and experiences with the Deaf population). It would be also be useful to try to understand how and why some parents overcome barriers to engaging with the Deaf community and others do not.

Among other child factors that could be examined, child age will likely influence parental engagement in socialization. The ethnic-racial literature suggests that the type and the quantity of socialization messages change with age. Some studies have found that racial socialization messages increase with age (Hughes & Chen, 1997; Neblett et al., 2009). This is assumed to be in response to greater cognitive skills and experiences with discrimination. Some transracial adoptive family studies have found that parental engagement in cultural socialization decreases with age (e.g., DeBerry et al., 1996). This may relate to decreased motivation from the parents or increased autonomy or resistance from adolescents. Future research should look at differences in DCSS and MSS across developmental ages to see if similar patterns emerge and why. (See

Appendix P for preliminary exploration of the combined socialization measures across school levels as well as the primary agent of socialization.)

Mental health. Contrary to expectations, cultural socialization did not predict depression/anxiety. This is inconsistent with the ethnic-racial socialization literature, which has found that ethnic-racial socialization negatively predicted mental health issues (Neblett et al., 2008; Wang et al., 2019). This could mean the scale used to measure depression and anxiety (i.e., the PHQ-4) may be insensitive to Deaf experiences or otherwise not be valid for a deaf and hard of hearing sample (e.g., language issues). Or this may mean that the pattern of associations between cultural socialization and depression from the ethnic-racial literature does not generalize to the deaf population. Future research should explore different measures of mental health that have been validated with a deaf sample to either illuminate associations with socialization that were missed in the current study, or to replicate these findings if no association exists. Additional well-being outcomes of socialization, such as resilience, attachment, independence, relationship quality, and academic performance could be explored.

Deaf cultural identity. This dissertation used the Deaf Acculturation Scale because it is the most widely used and accepted measure of Deaf cultural identity. However, this author would like to apply an adaptation of an ethnic identity measure that examines the *process* of identity development, rather than current status of identity. Such a scale would focus exclusively on the component of social identity related to membership in the Deaf culture, regardless of and separate from Hearing cultural identity. For example, the Ethnic Identity Scale (EIS; Umaña-Taylor et al., 2004) measures three processes of identity development based on the work of Erikson (1964), Marcia (1966), and Tajfel (H Tajfel, 1981): exploration, resolution, and

affirmation. This delineation would provide more information about how individuals reach their identity status by identifying how socialization may be promoting specific mechanisms of identity development (e.g., exploration). For example, it may be that parents' verbal messages about the importance of Deaf culture spark the process of exploration, or parent modeling of participation in Deaf cultural events may predict positive affirmation. Understanding how specific socialization practices are associated with these identity processes will illuminate what, more specifically, parents can say and do to promote healthy identity development.

There is great variability within the Deaf community, such as differences in language modality, device usage, family hearing status, family's philosophical perspective on being deaf (i.e., medical or cultural model), school setting, language of instruction, age at hearing loss, language preferences and skill levels, self-label choice, degree of exposure to deaf peers and mentors, and more (Parasnis, 1998). Given this rich variability, it is unlikely that there is only one way to have a healthy, achieved Deaf cultural identity. Focusing exclusively on the Deaf cultural identity component (without factoring in Hearing identity) with these processes of exploration, resolution, and affirmation could be more inclusive and respectful of the diversity of the community by assessing individuals' identity development without constraining what the resulting identity should look like, as the Deaf identity developmental model does.

Limitations

Several limitations of this study should be kept in mind when interpreting the results.

Assumption violations. There were issues with some of the measures violating the assumptions of the analyses used.

Unique sample. The use of Qualtrics for recruitment could be seen as a strength and a limitation of the study. The sample may be more diverse, including a larger proportion of marginalized subgroups of the deaf and hard of hearing population. However, the uniqueness of the sample limits the generalizability of the findings and underscores the need for replication and validation with other samples.

Sample sizes. The sample sizes of the groups with one deaf or hard of hearing parent and with two or more deaf and hard of hearing parents were too small to explore many meaningful differences between the parent status groups. By target-recruiting for adequate sample sizes in the future, research could empirically explore if deaf individuals who marry hearing individuals are culturally and behaviorally different from those who marry within the Deaf culture. Teasing apart group difference in deaf versus deaf-hearing parent dyads would enable a more nuanced understanding of how parents' hearing status and their cultural identity influence their parenting practices and their children's subsequent outcomes.

Exploratory. This study is unique, in that, to this author's knowledge, Deaf cultural socialization has not previously been studied empirically through the ethnic-racial socialization lens. Therefore, the results and conclusions cannot be generalized to the population without extensive replication. Many more studies are required with different recruitment, sampling, measures, research questions, and analyses to develop a theory of Deaf cultural socialization.

Correlational design. This study was correlational. This means that the interpretation of results must be tempered by a lack of understanding of causality. Deaf cultural socialization predicted higher levels of Deaf cultural identity. This could mean that parental engagement in socialization promotes, facilitates, elicits, or in some other way causes strong cultural identity to

develop. This is the explanation that is anticipated based on theory. However, since the analyses are correlational, it could be that those who have stronger Deaf cultural identities view their childhood experience through a different lens than those with stronger Hearing cultural identities. Those with Deaf or Bicultural identities may be more likely to remember and interpret things that their parents did and said as transmitting the meaning of being deaf.

Author's hearing status and cultural identity. Finally, a limitation of this dissertation is the hearing status and cultural identity of the author, a hearing individual and outsider of the Deaf cultural community. This author strives to be an ally of the community and the intention of this dissertation was to support hearing parents' efforts to connect their child with the Deaf cultural community. However, as an outsider, the author's ethnocentrism and associated biases must be acknowledged. Efforts were made to address this concern, including the review of the Deaf identity literature, coursework in ASL and Deaf culture, the preceding interviews with hearing parents of deaf and hard of hearing children (Husting, 2018), the focus groups with deaf and hard of hearing students and university staff during scale development, the ongoing contact with Deaf identity experts and members of the Deaf community (including inclusion of a Deaf identity expert on the dissertation committee), and presentations of preliminary findings at conferences related to child development and early hearing loss intervention. This dissertation is intended as a first step in a conversation with the Deaf identity research community. The results will be submitted to a journal of Deaf studies to elicit feedback from Deaf identity experts via peer review. Future research that builds upon this study will ideally involve interdisciplinary, multicultural teams (including Deaf researchers) to make sure the questions asked and the approach used to answer them are authentic, valid representations of the Deaf experience, and aligned with the goals of the Deaf cultural community.

Despite these limitations, this dissertation took important steps toward using the ethnic-racial socialization lens to understand the role of parents as agents of cultural socialization in their deaf and hard of hearing children's Deaf cultural identity development. The exciting results generate many new questions to be addressed by subsequent interdisciplinary research in the interest of developing a theory of Deaf cultural socialization.

References

- Arnett, J. J. (2000). Emerging adulthood: A theory of development from the late teens through the twenties. *American Psychologist*, 55(5), 469–480. <https://doi.org/10.1037//0003-066X.55.5.469>
- Bailey, J. D. (2006). A Practice Model to Protect the Ethnic Identity of International Adoptees. *Journal of Family Social Work*, 10(3), 1–11.
- Basow SA, Lilley E, Bookwala J, & McGillicuddy-Delisi A. (2008). Identity development and psychological well-being in Korean-born adoptees in the U.S. *American Journal of Orthopsychiatry (Wiley-Blackwell)*, 78(4), 473-480 8p.
- Bat-Chava, Y. (1993). Antecedents of self-esteem in deaf people: A meta-analytic review. *Rehabilitation Psychology*, 38(4), 221–234. <https://doi.org/10.1037/h0080303>
- Bat-Chava, Y. (2000). Diversity of Deaf Identities. *American Annals of the Deaf*, 145(5), 420–428.
- Batten, G., Oakes, P. M. 1, & Alexander, T. (2014). Factors Associated With Social Interactions Between Deaf Children and Their Hearing Peers: A Systematic Literature Review. *Journal of Deaf Studies & Deaf Education*, 19(3), 285–302.
- Bayaga, A. (2010). *Multinomial logistic regression: Usage and application in risk analysis*. *Journal of Applied Quantitative Methods*, 5(2).
- Berry, J. W. (1997). Immigration, Acculturation, and Adaptation. *Applied Psychology*, 46(1), 5–34. <https://doi.org/10.1111/j.1464-0597.1997.tb01087.x>
- Brown, T., & Krishnakumar, A. (2007). Development and Validation of the Adolescent Racial and Ethnic Socialization Scale (ARESS) in African American Families. *Journal of Youth & Adolescence*, 36(8), 1072–1085. <https://doi.org/10.1007/s10964-007-9197-z>
- Burke, P. J., & Stets, J. E. (2009). *Identity Theory*. Oxford University Press.

- Byrnes, L. J. (2011). Listening to the Voices of Students with Disabilities: What Do Adolescents with Hearing Loss Think about Different Educational Settings? *Deafness and Education International*, 13(2), 49–68.
- Caughy, M. O., Nettles, S. M., & Lima, J. (2011). Profiles of Racial Socialization among African American Parents: Correlates, Context, and Outcome. *Journal of Child and Family Studies*, 20(4), 491–502. (Springer, 233 Spring Street, New York, NY 10013. Tel: 800-777-4643; Tel: 212-460-1500; Fax: 212-348-4505; e-mail: service-ny@springer.com; Web site: <http://www.springerlink.com>).
- Chakawa, A., & Hoglund, W. L. G. (2016). Measuring parent cultural socialization practices: Extending the research to diverse racial–ethnic groups in Canada. *Canadian Journal of Behavioural Science / Revue Canadienne Des Sciences Du Comportement*, 48(2), 121–131. <https://doi.org/10.1037/cbs0000028>
- Chapman, M., & Dammeyer, J. (2017). The Significance of Deaf Identity for Psychological Well-Being. *The Journal of Deaf Studies and Deaf Education*, 22(2), 187–194. <https://doi.org/10.1093/deafed/enw073>
- Chen, G. (2014). Influential Factors of Deaf Identity Development. *Electronic Journal for Inclusive Education*, 3(2). Retrieved from <http://corescholar.libraries.wright.edu/ejie/vol3/iss2/5>
- Cohen, J. (2013). *Statistical power analysis for the behavioral sciences*. Routledge.
- Constantine, M. G., & Blackmon, S. M. (2002). Black Adolescents' Racial Socialization Experiences: Their Relations to Home, School, and Peer Self-Esteem. *Journal of Black Studies*, 32(3), 322.
- Cornell, S. L., & Lyness, K. P. (2004). Therapeutic Implications for Adolescent Deaf Identity and Self-Concept. *Journal of Feminist Family Therapy: An International Forum*, 16(3), 31–49. https://doi.org/10.1300/J086v16n03_02

- Crook, T., Raskin, A., & Eliot, J. (1981). Parent-Child Relationships and Adult Depression. *Child Development, 52*(3), 950. <https://doi.org/10.1111/1467-8624.ep8861497>
- Cross Jr., W. E. (1991). *Shades of black: Diversity in African-American identity*. Philadelphia, PA, US: Temple University Press.
- Crowe, T. V. (2003). Self-Esteem Scores Among Deaf College Students: An Examination of Gender and Parents' Hearing Status and Signing Ability. *Journal of Deaf Studies & Deaf Education, 8*(2), 199–206.
- Csizmadia, A., Rollins, A., & Kaneakua, J. P. 1. (2014). Ethnic-Racial Socialization and Its Correlates in Families of Black-White Biracial Children. *Family Relations, 63*(2), 259–270. <https://doi.org/10.1111/fare.12062>
- David, E. J. R., Okazaki, S., & Saw, A. (2009). Bicultural self-efficacy among college students: Initial scale development and mental health correlates. *Journal of Counseling Psychology, 56*(2), 211–226. <https://doi.org/10.1037/a0015419>
- DeBerry, K. M., Scarr, S., & Weinberg, R. (1996). Family racial socialization and ecological competence: Longitudinal assessments of African-American transracial adoptees. *Child Development, 67*(5), 2375–2399. <https://doi.org/10.2307/1131629>
- Decker, K. B., Vallotton, C. D., & Johnson, H. A. (2012). Parents' Communication Decision for Children with Hearing Loss: Sources of Information and Influence. *American Annals of the Deaf, 157*(4), 326-339 14p.
- Denollet, J., Smolderen, K. G. E., van den Broek, K. C., & Pedersen, S. S. (2007). The 10-item Remembered Relationship with Parents (RRP¹⁰) scale: Two-factor model and association with adult depressive symptoms. *Journal of Affective Disorders, 100*(1–3), 179–189. <http://dx.doi.org.ezproxy.lib.uwm.edu/10.1016/j.jad.2006.10.009>

- DeVellis, R. F. (2016). *Scale Development: Theory and Applications*. SAGE Publications.
- Diener, E., Emmons, R. A., Larsen, R. J., & Griffin, S. (1985). The Satisfaction With Life Scale. *Journal of Personality Assessment*, 49(1), 71.
- Duncan, J. (2009). Parental readiness for cochlear implant decision-making. *Cochlear Implants International*, 10(S1), 38–42. <https://doi.org/10.1002/cii.384>
- Eleweke, C. J., & Rodda, M. (2000). Factors contributing to parents' selection of a communication mode to use with their deaf children. *American Annals Of The Deaf*, 145(4), 375–383.
- Else-Quest, N. M., & Morse, E. (2015). Ethnic variations in parental ethnic socialization and adolescent ethnic identity: A longitudinal study. *Cultural Diversity and Ethnic Minority Psychology*, 21(1), 54–64. <https://doi.org/10.1037/a0037820>
- Erikson, E. H. (1964). *Childhood and society*. (2nd Ed.). Oxford, England: W. W. Norton. (1965-10989-000).
- Erting, C. (1994). *The Deaf Way: Perspectives from the International Conference on Deaf Culture*. Gallaudet University Press.
- Ford, H., & Kent, S. (2013). The Experiences of Bilingualism Within the Deaf and the Hearing World: The Views of d/Deaf Young People. *Deafness & Education International*, 15(1), 29-51 23p. <https://doi.org/10.1179/1557069X12Y.0000000013>
- Foster, S., & Kinuthia, W. (2003). Deaf Persons of Asian American, Hispanic American, and African American Backgrounds: A Study of Intraindividual Diversity and Identity. *Journal of Deaf Studies and Deaf Education*, 8(3), 271–290.

- Friedlander, M. L., Larney, L. C., & Skau, M. (2000). Bicultural identification: Experiences of internationally adopted children and their parents. *Journal of Counseling Psychology*, 47(2), 187–198. <https://doi.org/10.1037/0022-0167.47.2.187>
- Gallaudet Research Institute (April 2011). Regional and National Summary Report of Data from the 2009-10 Annual Survey of Deaf and Hard of Hearing Children and Youth. Washington, DC: GRI, Gallaudet University.
- Glickman, N. S. (1993). *Deaf identity development: Construction and validation of a theoretical model*. (Unpublished dissertation, University of Massachusetts, Amherst). Retrieved from http://scholarworks.umass.edu/cgi/viewcontent.cgi?article=2202&context=dissertations_1
- Glickman, N. S. (1996). The development of culturally deaf identities. In N. S. Glickman & M. A. Harvey (Eds.), *Culturally affirmative psychotherapy with deaf persons*. (pp. 115–153). Mahwah, NJ: Lawrence Erlbaum Associates Publishers. (1996-06469-005).
- Glickman, N. S., & Carey, J. C. (1993). Measuring deaf cultural identities: A preliminary investigation. *Rehabilitation Psychology*, 38(4), 275–283. <https://doi.org/10.1037/h0080304>
- Gordon, R. E. (1998). *Worldview, self-concept, and cultural identity patterns of deaf adolescents: Implications for counseling*. ProQuest Information & Learning, US. (1998-95004-437).
- Grusec, J. E., & Davidov, M. (2010a). Integrating Different Perspectives on Socialization Theory and Research: A Domain-Specific Approach. *Child Development*, 81(3), 687–709. <https://doi.org/10.1111/j.1467-8624.2010.01426.x>

- Grusec, J. E., & Davidov, M. (2010b). Integrating Different Perspectives on Socialization Theory and Research: A Domain-Specific Approach. *Child Development, 81*(3), 687–709. <https://doi.org/10.1111/j.1467-8624.2010.01426.x>
- Hadjikakou, K., & Nikolarazi, M. (2007). The Impact of Personal Educational Experiences and Communication Practices on the Construction of Deaf Identity in Cyprus. *American Annals of the Deaf, 152*(4), 398–414.
- Hardin, B. J., Blanchard, S. B., Kemmery, M. A., Appenzeller, M., & Parker, S. D. (2014). Family-Centered Practices and American Sign Language (ASL): Challenges and Recommendations. *Exceptional Children, 81*(1), 107–123. <https://doi.org/10.1177/0014402914532229>
- Hardonk S, Bosteels S, Je Desnerck G, Loots G, Van Hove G, Van Kerschaver E, ... Louckx F. (2010). Pediatric Cochlear Implantation: A Qualitative Study of Parental Decision-Making Processes in Flanders, Belgium. *American Annals of the Deaf, 155*(3), 339-352 14p.
- Hardy, J. (2010). The development of a sense of identity in deaf adolescents in mainstream schools. *Educational & Child Psychology, 27*(2), 58–67.
- Hintermair, M. (2006). Parental Resources, Parental Stress, and Socioemotional Development of Deaf and Hard of Hearing Children. *Journal of Deaf Studies & Deaf Education, 11*(4), 493–513.
- Hintermair, M. (2008). Self-Esteem and Satisfaction with Life of Deaf and Hard-of-Hearing People—A Resource-Oriented Approach to Identity Work. *Journal of Deaf Studies and Deaf Education, 13*(2), 278–300.

- Hirsch, E. D., Kett, J. F., & Trefil, J. S. (2002). *The New Dictionary of Cultural Literacy*. Houghton Mifflin Harcourt.
- Holcomb, T. K. (1997). Development of deaf bicultural identity. *American Annals of the Deaf*, 142(2), 89–93.
- Holcomb, T. K. (2013). *Introduction to American Deaf culture*. New York, NY, US: Oxford University Press. (2013-06572-000).
- Hughes, D. (2003). Correlates of African American and Latino Parents' Messages to Children About Ethnicity and Race: A Comparative Study of Racial Socialization. *American Journal of Community Psychology*, 31(1/2), 15–33.
- Hughes, D., & Chen, L. (1997). When and what parents tell children about race: An examination of race-related socialization among African American families. *Applied Developmental Science*, 1(4), 200–214. https://doi.org/10.1207/s1532480xads0104_4
- Hughes, D., Rodriguez, J., Smith, E. P., Johnson, D. J., Stevenson, H. C., & Spicer, P. (2006). Parents' ethnic-racial socialization practices: A review of research and directions for future study. *Developmental Psychology*, 42(5), 747–770. <https://doi.org/10.1037/0012-1649.42.5.747>
- Husting, M. (2018). *Deaf Identity and Cultural Socialization: Perspectives and Practices of Hearing Parents of Deaf and Hard of Hearing Children*. Unpublished manuscript.
- Hyde, M., Punch, R., & Komesaroff, L. (2010). Coming to a Decision About Cochlear Implantation: Parents Making Choices for their Deaf Children. *Journal of Deaf Studies and Deaf Education*, 15(2), 162–178. <https://doi.org/10.1093/deafed/enq004>

- Israelite, N., Ower, J., & Goldstein, G. (2002). Hard-of-hearing adolescents and identity construction: Influences of school experiences, peers, and teachers. *Journal of Deaf Studies & Deaf Education*, 7(2), 134-148 15p.
- Johnston, K. E., Swim, J. K., Saltsman, B. M., Deater-Deckard, K., & Petrill, S. A. (2007). Mothers' Racial, Ethnic, and Cultural Socialization of Transracially Adopted Asian Children. *Family Relations*, 56(4), 390–402. <https://doi.org/10.1111/j.1741-3729.2007.00468.x>
- Kemmerly, M. A., & Compton, M. V. (2014). Are You Deaf or Hard of Hearing? Which Do You Go by: Perceptions of Identity in Families of Students with Hearing Loss. *Volta Review*, 114(2), 157-192 36p.
- Kline, R. B. (2015). *Principles and Practice of Structural Equation Modeling, Fourth Edition*. Guilford Publications.
- Kluwin TN, & Stewart DA. (2000). Cochlear implants for younger children: A preliminary description of the parental decision process and outcomes. *American Annals of the Deaf*, 145(1), 26-32 7p.
- Kobosko, J., & Zalewska, M. (2011). Maternal Identity of Hearing Mothers of Deaf Adolescents. Empirical Studies-An Interpersonal Approach. *Volta Review*, 111(1), 39–59.
- Kroenke, K., Spitzer, R. L., Williams, J. B. W., & Löwe, B. (2009). An ultra-brief screening scale for anxiety and depression: The PHQ-4. *Psychosomatics*, 50(6), 613–621. <https://doi.org/10.1176/appi.psy.50.6.613>
- Kuo, B. C. H. (2014). Coping, acculturation, and psychological adaptation among migrants: A theoretical and empirical review and synthesis of the literature. *Health Psychology and Behavioral Medicine*, 2(1), 16–33. <https://doi.org/10.1080/21642850.2013.843459>

- Ladd, P., & Lane, H. (2013). Deaf Ethnicity, Deafhood, and Their Relationship. *Sign Language Studies, 13*(4), 565–578. (Gallaudet University Press. 800 Florida Avenue NE, Denison House, Washington, DC 20002-3695. Tel: 202-651-5488; Fax: 202-651-5489; Web site: <http://gupress.gallaudet.edu/SLS.html>).
- Lane, H. (1999). *The Mask of Benevolence: Disabling the Deaf Community*. New York: Alfred A Knopf.
- Lane, H., Hoffmeister, R., & Bahan, B. (1996). *A journey into the deaf-world*. San Diego, CA, England: Dawn Sign Press. (1996-98378-000).
- Langrehr, K. J. (2014). Transracially adoptive parents' color-blind attitudes and views toward socialization: Cross-racial friendships as a moderator. *Cultural Diversity & Ethnic Minority Psychology, 20*(4), 601-610 10p. <https://doi.org/10.1037/a0036528>
- Lee, R. M. (2003). The Transracial Adoption Paradox. *The Counseling Psychologist, 31*(6), 711–744. <https://doi.org/10.1177/0011000003258087>
- Lee, R. M., Grotevant, H. D., Hellerstedt, W. L., & Gunnar, M. R. (2006). Cultural socialization in families with internationally adopted children. *Journal of Family Psychology, 20*(4), 571–580. <https://doi.org/10.1037/0893-3200.20.4.571>
- Leigh, I. W. (2009). *A lens on deaf identities*. New York, NY, US: Oxford University Press. (2009-06207-000).
- Leigh, I. W., Andrews, J. F., & Harris, R. (2016). *Deaf Culture: Exploring Deaf Communities in the United States*. Plural Publishing.
- Leigh, I. W., & Anthony, S. (1999). Parent bonding in clinically depressed deaf and hard-of-hearing adults. *Journal of Deaf Studies and Deaf Education, 4*(1), 28–36. <http://dx.doi.org.ezproxy.lib.uwm.edu/10.1093/deafed/4.1.28>

- Leigh, I. W., Marcus, A. L., Dobosh, P. K., & Allen, T. E. (1998). Deaf/Hearing Cultural Identity Paradigms: Modification of the Deaf Identity Development Scale. *Journal of Deaf Studies & Deaf Education*, 3(4), 329–338.
- Leigh, I. W., Maxwell-McCaw, D., Bat-Chava, Y., & Christiansen, J. B. (2009). Correlates of psychosocial adjustment in deaf adolescents with and without cochlear implants: A preliminary investigation. *Journal of Deaf Studies and Deaf Education*, 14(2), 244–259.
- Leigh, I. W., Robins, C. J., Welkowitz, J., & Bond, R. N. (1989). Toward greater understanding of depression in deaf individuals. *American Annals of the Deaf*, 134(4), 249–254.
<http://dx.doi.org.ezproxy.lib.uwm.edu/10.1353/aad.2012.0662>
- Lesane-Brown, C. L. (2006). A Review of Race Socialization within Black Families. *Developmental Review*, 26(4), 400–426.
<http://dx.doi.org.ezproxy.lib.uwm.edu/10.1016/j.dr.2006.02.001>
- Lesane-Brown, C. L., Brown, T. N., Caldwell, C. H., & Sellers, R. M. (2005). The Comprehensive Race Socialization Inventory. *Journal of Black Studies*, 36(2), 163–190.
<https://doi.org/10.1177/0021934704273457>
- Li Y, Bain L, & Steinberg AG. (2003). Parental decision making and the choice of communication modality for the child who is deaf. *Archives of Pediatrics & Adolescent Medicine*, 157(2), 162–168.
- Listman, J., Rogers, K. D., & Hauser, P. C. (2011). Community cultural wealth and deaf adolescents' resilience. In D. H. [Ed] (ORCID: 0000-0003-0516-9174) Zand & K. J. [Ed] Pierce (Eds.), *Resilience in deaf children: Adaptation through emerging adulthood* (pp. 279–297, Chapter xxi, 396 Pages). Retrieved from

<http://search.proquest.com.ezproxy.lib.uwm.edu/psycinfo/docview/871543542/B0616CF5DD4341F8PQ/1>

Liu, L. L., & Lau, A. S. (2013). Teaching About Race/Ethnicity and Racism Matters: An Examination of How Perceived Ethnic Racial Socialization Processes Are Associated With Depression Symptoms. *Cultural Diversity & Ethnic Minority Psychology, 19*(4), 383–394. <https://doi.org/10.1037/a0033447>

Manzi. (2014). Bicultural Identity Integration of Transracial Adolescent Adoptees: Antecedents and Outcomes. *Journal of Cross-Cultural Psychology, 45*, 888. DOI: 10.1177/0022022114530495. Retrieved March 24, 2016, from https://www.researchgate.net/profile/Claudia_Manzi/publication/266327177_Bicultural_Identity_Integration_of_Transracial_Adolescent_Adoptees_Antecedents_and_Outcomes/links/5480690d0cf250f1edc19465.pdf

Marcia, J. E. (1966). Development and validation of ego-identity status. *Journal of Personality and Social Psychology, 3*(5), 551–558. <https://doi.org/10.1037/h0023281>

Marschark, M., Zettler, I., & Dammeyer, J. (2017). Social Dominance Orientation, Language Orientation, and Deaf Identity. *The Journal of Deaf Studies and Deaf Education, 22*(3), 269–277. <https://doi.org/10.1093/deafed/enx018>

Massatti, R., Vonk, M. E., & Gregoire, T. (n.d.). Reliability and validity of the Transracial Adoption Parenting Scale. Retrieved June 6, 2016, from https://www.researchgate.net/profile/Rick_Massatti/publication/228058632_Reliability_and_Validity_of_the_Transracial_Adoption_Parenting_Scale/links/02bfe50f826a3ed6fc000000.pdf

Matsunaga, M. (2010). How to factor-analyze your data right: Do's, don'ts, and how-to's.

International Journal of Psychological Research, 3(1), 97.

<https://doi.org/10.21500/20112084.854>

Maxwell-McCaw, D. (2001). *Acculturation and psychological well-being in deaf and hard-of-hearing people* (ProQuest Information & Learning (US)). Retrieved from

<http://search.proquest.com.ezproxy.lib.uwm.edu/psycinfo/docview/619717542/5A668648B72B4256PQ/1>

Maxwell-McCaw, D., Leigh, I., & Marcus, A. (2000). *Socialidentityindeafculture.pdf*. Retrieved May 22, 2016, from

<http://martintolley.com/DevChild/documents/socialidentityindeafculture.pdf>

Maxwell-McCaw, D., & Zea, M. C. (2011). The Deaf Acculturation Scale (DAS): Development and validation of a 58-item measure. *Journal of Deaf Studies and Deaf Education*, 16(3), 325–342. <https://doi.org/10.1093/deafed/enq061>

McCranie, E. W., & Bass, J. D. (1984). Childhood family antecedents of dependency and self-criticism: Implications for depression. *Journal of Abnormal Psychology*, 93(1), 3–8.

<http://dx.doi.org.ezproxy.lib.uwm.edu/10.1037/0021-843X.93.1.3>

McIlroy, G., & Storbeck, C. (2011). Development of Deaf Identity: An Ethnographic Study.

Journal of Deaf Studies & Deaf Education, 16(4), 494–511.

McLaughlin, E. B. (2012). *Homogamy among Deaf and Hard of Hearing College Students*

(Ph.D., Gallaudet University). Retrieved from

<http://search.proquest.com/docview/1314418876/abstract/BA875F15B92F468CPQ/19>

- Meadow, K. (1972). Sociolinguistics, sign language, and the deaf sub-culture. In O'Rourke, T (Ed.), *Psycholinguistics and Total Communication: The state of the art*. (pp. 113-123). Washington: American Annals of the Deaf.
- Meadow, K. P. (2005). Early Manual Communication in Relation to the Deaf Child's Intellectual, Social, and Communicative Functioning. *Journal of Deaf Studies and Deaf Education*, 10(4), 321–329. (Oxford University Press, Great Clarendon Street, Oxford OX2 6DP UK. Tel: +44 1865-353907; Fax: +44 1865-353485; e-mail: jnls.cust.serv@oxfordjournals.org; Web site: <http://jdsde.oxfordjournals.org/>).
- Mitchell, R. E., & Karchmer, M. A. (2004). Chasing the Mythical Ten Percent: Parental Hearing Status of Deaf and Hard of Hearing Students in the United States. *Sign Language Studies*, 4(2), 138–163. (Gallaudet University Press. 800 Florida Avenue NE, Denison House, Washington, DC 20002-3695. Tel: 202-651-5488; Fax: 202-651-5489; Web site: <http://gupress.gallaudet.edu/SLS.html>).
- Most T, Wiesel A, & Blitzer T. (2007). Identity and attitudes towards cochlear implant among deaf and hard of hearing adolescents. *Deafness & Education International*, 9(2), 68-82 15p.
- Murry, V. M., Smith, E. P., & Hill, N. E. (2001). Race, Ethnicity, and Culture in Studies of Families in Context. *Journal of Marriage & Family*, 63(4), 911.
- Neblett, E., Smalls, C., Ford, K., Nguyễn, H., & Sellers, R. (2009). Racial Socialization and Racial Identity: African American Parents' Messages About Race as Precursors to Identity. *Journal of Youth & Adolescence*, 38(2), 189–203.
<https://doi.org/10.1007/s10964-008-9359-7>

- Neblett, E. W., Philip, C. L., Cogburn, C. D., & Sellers, R. M. (2006). African American Adolescents' Discrimination Experiences and Academic Achievement: Racial Socialization as a Cultural Compensatory and Protective Factor. *Journal of Black Psychology*, 32(2), 199–218. <https://doi.org/10.1177/0095798406287072>
- Neblett, E. W., White, R. L., Ford, K. R., Philip, C. L., Nguyễn, H. X., & Sellers, R. M. (2008a). Patterns of Racial Socialization and Psychological Adjustment: Can Parental Communications About Race Reduce the Impact of Racial Discrimination? *Journal of Research on Adolescence (Wiley-Blackwell)*, 18(3), 477–515. <https://doi.org/10.1111/j.1532-7795.2008.00568.x>
- Neblett, E. W., White, R. L., Ford, K. R., Philip, C. L., Nguyễn, H. X., & Sellers, R. M. (2008b). Patterns of Racial Socialization and Psychological Adjustment: Can Parental Communications About Race Reduce the Impact of Racial Discrimination? *Journal of Research on Adolescence (Wiley-Blackwell)*, 18(3), 477–515. <https://doi.org/10.1111/j.1532-7795.2008.00568.x>
- Neblett Jr., E. W., Banks, K. H., Cooper, S. M., & Smalls-Glover, C. (2013). Racial Identity Mediates the Association Between Ethnic-Racial Socialization and Depressive Symptoms. *Cultural Diversity & Ethnic Minority Psychology*, 19(2), 200–207. <https://doi.org/10.1037/a0032205>
- Neblett Jr., E. W., Nicole, J., & Sellers, R. M. (2004). The Role of Racial Identity in Managing Daily Racial Hassles. In *Decade of Behavior. Racial identity in context: The legacy of Kenneth B. Clark* (pp. 77–90). <https://doi.org/10.1037/10812-005>
- Nikolarazi, M. (2007). Analysing the concept of deaf identity. *Hellenic Journal of Psychology*, 4(2), 185–204. (2007-11419-004).

- Ohna, S. E. (2004). Deaf in my own way: Identity, learning and narratives. *Deafness & Education International*, 6(1), 20–38.
- Oliva, G. A. (2004). *Alone in the Mainstream: A Deaf Woman Remembers Public School*. Gallaudet University Press.
- Paasch-Anderson, J., Lamborn, S. D., & Azen, R. (2019). Beyond what, to how: Different ways African American adolescents receive ethnic and racial socialization messages. *Cultural Diversity & Ethnic Minority Psychology*. <https://doi.org/10.1037/cdp0000269>
- Padden, C., & Humphries, T. (1988). *Deaf in America: Voices from a Culture*. : Ear and Hearing. Retrieved May 19, 2016, from LWW website: http://journals.lww.com/ear-hearing/Fulltext/1989/04000/Deaf_in_America__Voices_from_a_Culture_.22.aspx
- Padden, C., & Humphries, T. (2009). *Inside Deaf Culture*. Harvard University Press.
- Parasnis, I. (1998). *Cultural and Language Diversity and the Deaf Experience*. Cambridge University Press.
- Parke, R. D., & Buriel, R. (1998). Socialization in the family: Ethnic and ecological perspectives. In N. [Ed Eisenberg (Ed.), *5th ed.: Vol. Vol. 3* (pp. 463–552, Chapter xxiv, 1208 Pages). Retrieved from <http://search.proquest.com.ezproxy.lib.uwm.edu/docview/620708854/C18BD4B25C2349AFPQ/2>
- Phinney, J. S. (1989). Stages of Ethnic Identity Development in Minority Group Adolescents. *The Journal of Early Adolescence*, 9(1–2), 34–49. <https://doi.org/10.1177/0272431689091004>
- Phinney, J. S. (1990). Ethnic identity in adolescents and adults: Review of research. *Psychological Bulletin*, 108(3), 499–514. <https://doi.org/10.1037/0033-2909.108.3.499>

- Phinney, J. S. (1992). The multigroup ethnic identity measure a new scale for use with diverse groups. *Journal of Adolescent Research*, 7(2), 156–176.
- Phinney, J. S. (1996). Understanding ethnic diversity: The role of ethnic identity. *American Behavioral Scientist*, 40(2), 143–152. <https://doi.org/10.1177/0002764296040002005>
- Phinney, J. S., & Chavira, V. (1995). Parental Ethnic Socialization and Adolescent Coping With Problems Related to Ethnicity. *Journal of Research on Adolescence (Lawrence Erlbaum)*, 5(1), 31–53.
- Phinney, J. S., & Devich-Navarro, M. (1997). Variations in Bicultural Identification Among African American and Mexican American Adolescents. *Journal of Research on Adolescence (Lawrence Erlbaum)*, 7(1), 3–32.
- Phinney, J. S., Jacoby, B., & Silva, C. (2007). Positive intergroup attitudes: The role of ethnic identity. *International Journal of Behavioral Development*, 31(5), 478–490.
<https://doi.org/10.1177/0165025407081466>
- Phinney, J. S., & Ong, A. D. (2007). Conceptualization and measurement of ethnic identity: Current status and future directions. *Journal of Counseling Psychology*, 54(3), 271–281.
<https://doi.org/10.1037/0022-0167.54.3.271>
- Quintana, S. M., & Vera, E. M. (1999). Mexican American children's ethnic identity, understanding of ethnic prejudice, and parental ethnic socialization. *Hispanic Journal of Behavioral Sciences*, 21(4), 387–404. <https://doi.org/10.1177/0739986399214001>
- Rivas-Drake, Deborah. (2012). Ethnic identity and adjustment: The mediating role of sense of community. *Cultural Diversity and Ethnic Minority Psychology*, 18(2), 210–215.
<https://doi.org/10.1037/a0027011>

- Rivas-Drake, Deborah, Hughes, D., & Way, N. (2008). A Closer Look at Peer Discrimination, Ethnic Identity, and Psychological Well-being Among Urban Chinese American Sixth Graders. *Journal of Youth and Adolescence*, 37(1), 12–21.
<https://doi.org/10.1007/s10964-007-9227-x>
- Rivas-Drake, Deborah, Hughes, D., & Way, N. (2009). A Preliminary Analysis of Associations among Ethnic-Racial Socialization, Ethnic Discrimination, and Ethnic Identity among Urban Sixth Graders. *Journal of Research on Adolescence*, 19(3), 558–584. (Wiley-Blackwell. 350 Main Street, Malden, MA 02148. Tel: 800-835-6770; Tel: 781-388-8598; Fax: 781-388-8232; e-mail: cs-journals@wiley.com; Web site: <http://www.wiley.com/WileyCDA/>).
- Rivas-Drake, Deborah, Syed, M., Umaña-Taylor, A., Markstrom, C., French, S., Schwartz, S. J., & Lee, R. (2014). Feeling good, happy, and proud: A meta-analysis of positive ethnic-racial affect and adjustment. *Child Development*, 85(1), 77-102 26p.
<https://doi.org/10.1111/cdev.12175>
- Rivas-Drake, Deborah1. (2011). Ethnic-Racial Socialization and Adjustment Among Latino College Students: The Mediating Roles of Ethnic Centrality, Public Regard, and Perceived Barriers to Opportunity. *Journal of Youth & Adolescence*, 40(5), 606–619.
- Rollins, A., & Hunter, A. G. 2. (2013). Racial Socialization of Biracial Youth: Maternal Messages and Approaches to Address Discrimination. *Family Relations*, 62(1), 140–153.
<https://doi.org/10.1111/j.1741-3729.2012.00748.x>
- Rosenberg, M. (1986). *Conceiving the self*. Retrieved from <http://agris.fao.org/agris-search/search.do?recordID=US201300408437>

- Rosenberg, M. (1989). *Society and the adolescent self-image*. Retrieved from <http://search.proquest.com.ezproxy.lib.uwm.edu/psycinfo/docview/617871219/A30F825C4E14DC7PQ/2>
- Samuels, G. M. (2009). "Being Raised by White People": Navigating Racial Difference Among Adopted Multiracial Adults. *Journal of Marriage & Family*, 71(1), 80–94. <https://doi.org/10.1111/j.1741-3737.2008.00581.x>
- Scheetz, N. A. (2004). *Psychosocial aspects of deafness*. Allyn & Bacon.
- Schorr, E. A. (2006). Early Cochlear Implant Experience and Emotional Functioning During Childhood: Loneliness in Middle and Late Childhood. *Volta Review*, 106(3), 365–379.
- Schwab, J. A. (2002). Multinomial logistic regression: Basic relationships and complete problems. <http://www.utexas.edu/courses/schwab/sw388r7/SolvingProblems/>
- Schwartz, S. J., Kim, S. Y., Whitbourne, S. K., Zamboanga, B. L., Weisskirch, R. S., Forthun, L. F., ... Luyckx, K. (2013). Converging identities: Dimensions of acculturation and personal identity status among immigrant college students. *Cultural Diversity and Ethnic Minority Psychology*, 19(2), 155–165. <http://dx.doi.org.ezproxy.lib.uwm.edu/10.1037/a0030753>
- Schwartz, S. J., Unger, J. B., Zamboanga, B. L., & Szapocznik, J. (2010). Rethinking the concept of acculturation: Implications for theory and research. *American Psychologist*, 65(4), 237–251. <http://dx.doi.org.ezproxy.lib.uwm.edu/10.1037/a0019330>
- Schwartz, S. J., Zamboanga, B. L., & Jarvis, L. H. (2007). Ethnic identity and acculturation in Hispanic early adolescents: Mediated relationships to academic grades, prosocial behaviors, and externalizing symptoms. *Cultural Diversity and Ethnic Minority*

Psychology, 13(4), 364–373. <http://dx.doi.org.ezproxy.lib.uwm.edu/10.1037/1099-9809.13.4.364>

Solomon, A. (2012). *Far From the Tree: Parents, Children and the Search for Identity*. Simon and Schuster.

Stets, J. E., & Serpe, R. T. (2016). *New Directions in Identity Theory and Research*. Oxford University Press.

Sue, D. W., & Sue, D. (1999). *Counseling the culturally different: Theory and practice (3rd ed.)*. Hoboken, NJ, US: John Wiley & Sons Inc. (1999-02325-000).

Tajfel, H. (1981). *Human groups and social categories: Studies in social psychology*.

Umaña-Taylor, A. (2001). Ethnic identity development among Mexican-origin Latino adolescents living in the United States. *Unpublished doctoral dissertation, University of Missouri, Columbia*.

Umaña-Taylor, A. J., & Fine, M. A. (2001). Methodological Implications of Grouping Latino Adolescents into One Collective Ethnic Group. *Hispanic Journal of Behavioral Sciences*, 23(4), 347–362. <https://doi.org/10.1177/0739986301234001>

Umaña-Taylor, A. J., & Fine, M. A. (2004). Examining Ethnic Identity Among Mexican-Origin Adolescents Living in the United States. *Hispanic Journal of Behavioral Sciences*, 26(1), 36–59. <https://doi.org/10.1177/0739986303262143>

Umaña-Taylor, A. J., Yazedjian, A., & Bámaca-Gómez, M. (2004a). Developing the Ethnic Identity Scale Using Eriksonian and Social Identity Perspectives. *Identity*, 4(1), 9–38. https://doi.org/10.1207/S1532706XID0401_2

Umaña-Taylor, A. J., Yazedjian, A., & Bámaca-Gómez, M. (2004b). Developing the ethnic identity scale using Eriksonian and social identity perspectives. *Identity: An International*

Journal of Theory and Research, 4(1), 9–38.

https://doi.org/10.1207/S1532706XID0401_2

United Nations (1989). Convention on the Rights of the Child, Article 21. Geneva, Switzerland:

Office of the United Nations High Commissioner for Human Rights.

van Gurp, S. (2001). Self-Concept of Deaf Secondary School Students in Different Educational Settings. *Journal of Deaf Studies & Deaf Education*, 6(1), 54.

Vandiver, B. J., Fhagen-Smith, P. E., & Cokley, K. O. (2001). Cross's nigrescence model: From theory to scale to theory. *Journal of Multicultural Counseling & Development*, 29(3), 174–200.

Vonk, M. E. (2001). Cultural Competence for Transracial Adoptive Parents. *Social Work*, 46(3), 246–255.

Wakefield, W. D., & Hudley, C. (2007). Ethnic and Racial Identity and Adolescent Well-Being. *Theory Into Practice*, 46(2), 147–154.

Wang, M.-T., Henry, D. A., Link to external site, this link will open in a new window, Smith, L. V., Link to external site, this link will open in a new window, Huguley, J. P., ... Link to external site, this link will open in a new window. (2019). Parental ethnic-racial socialization practices and children of color's psychosocial and behavioral adjustment: A systematic review and meta-analysis. *American Psychologist*.
<http://dx.doi.org.ezproxy.lib.uwm.edu/10.1037/amp0000464>

Wang, Y., Benner, A. D., & Kim, S. Y. (2015). The Cultural Socialization Scale: Assessing family and peer socialization toward heritage and mainstream cultures. *Psychological Assessment*, 27(4), 1452–1462. <https://doi.org/10.1037/pas0000136>

- Ward, C. (2008). Thinking outside the Berry boxes: New perspectives on identity, acculturation and intercultural relations. *International Journal of Intercultural Relations*, 32(2), 105–114. <https://doi.org/10.1016/j.ijintrel.2007.11.002>
- Weinberg, N., & Sterritt, M. (1986). Disability and identity: A study of identity patterns in adolescents with hearing impairments. *Rehabilitation Psychology*, 31(2), 95–102. <https://doi.org/10.1037/h0091538>
- Whyte, A., & Guiffrida, D. (2008). Counseling Deaf college students: The case of Shea. Retrieved May 29, 2019, from Journal of College Counseling, 11.2, p184-192 website: https://s3.amazonaws.com/academia.edu.documents/38806147/The_Case_of_Shea.pdf?AWSAccessKeyId=AKIAIWOWYYGZ2Y53UL3A&Expires=1559155905&Signature=HbGkqi0tQMKTSEw9ZdOWF%2Fongrk%3D&response-content-disposition=inline%3B%20filename%3DCounseling_Deaf_College_Students_The_Cas.pdf
- Wolf Craig, K. S. (2012). *Body Image, Deaf Identity, and the Tripartite Model: A Preliminary Study* (Ph.D., Gallaudet University). Retrieved from <http://search.proquest.com/docview/1172127667/abstract/BA875F15B92F468CPQ/17>
- Wolsey, J.-L., Clark, M., van der Mark, L., & Suggs, C. (2017). Life Scripts and Life Stories of Oral Deaf Individuals. *Journal of Developmental & Physical Disabilities*, 29(1), 77–103. <https://doi.org/10.1007/s10882-016-9487-z>
- Wright, L. J. (1987). *A Study of Deaf Cultural Identity through a Comparison of Young Deaf Adults of Hearing Parents and Young Deaf Adults of Deaf Parents*.
- Yap, S. C. Y., Settles, I. H., & Pratt-Hyatt, J. S. (2011). Mediators of the relationship between racial identity and life satisfaction in a community sample of African American women

- and men. *Cultural Diversity and Ethnic Minority Psychology*, 17(1), 89–97.
<https://doi.org/10.1037/a0022535>
- Yasui, M. (2015). A review of the empirical assessment of processes in ethnic–racial socialization: Examining methodological advances and future areas of development. *Developmental Review*, 37, 1–40. <https://doi.org/10.1016/j.dr.2015.03.001>
- Yong, A. G., & Pearce, S. (2013). A Beginner’s Guide to Factor Analysis: Focusing on Exploratory Factor Analysis. *Tutorials in Quantitative Methods for Psychology*, 9(2), 79–94. <https://doi.org/10.20982/tqmp.09.2.p079>
- Yoon, D. P. (2001). Causal modeling predicting psychological adjustment of Korean-born adolescent adoptees. *Journal of Human Behavior in the Social Environment*, 3(3–4), 65–82. https://doi.org/10.1300/J137v03n03_06
- Yoon, E., Chang, C.-T., Kim, S., Clawson, A., Cleary, S. E., Hansen, M., ... Gomes, A. M. (2013). A meta-analysis of acculturation/enculturation and mental health. *Journal of Counseling Psychology*, 60(1), 15–30. <https://doi.org/10.1037/a0030652>
- Zayas, L. H., & Solari, F. (1994). Early childhood socialization in Hispanic families: Context, culture, and practice implications. *Professional Psychology: Research and Practice*, 25(3), 200–206. <https://doi.org/10.1037/0735-7028.25.3.200>
- Zea, M. C., Asner-Self, K. K., Birman, D., & Buki, L. P. (2003). The Abbreviated Multidimensional Acculturation Scale: Empirical Validation With Two Latino/Latina Samples. *Cultural Diversity & Ethnic Minority Psychology*, 9(2), 107–126.
<https://doi.org/10.1037/1099-9809.9.2.107>

Appendix A

Consent Form

University of Wisconsin-Milwaukee

Informed Consent to Participate in Research

Study title: Exploring the Role of Parents in Deaf Cultural Identity Development

Researchers: Macrae Husting, M.S. and Jacqueline Nguyen, PhD, University of Wisconsin-Milwaukee, Educational Psychology, Learning and Development

Young adults who are deaf or hard of hearing are invited to take a survey for research. It is completely voluntary. You can always change your mind and drop out without consequences.

What is the purpose of this study?

We want to understand two things:

- What parents say and do to teach their children what it means to be deaf or hard of hearing
- How your parent(s) influenced who you are now

What will I do? You will take a survey online. It will take about 15 minutes. The survey will ask questions about your background and things your parent(s) may have done when you were a child. It will also ask you questions about how you see yourself today.

Risks: Some questions may be personal. You can skip them or quit the survey at any time. Anytime you share any information online there are risks. Your data could be hacked or seen by someone who shouldn't have access to it. We are using a secure system and collecting data anonymously to minimize this risk.

Possible benefits: You may not benefit personally from taking the survey. The study could help parents know how to support their deaf or hard of hearing child.

Compensation: You will receive the payment you were offered in the invitation.

How long will it take? The survey will take about 15 minutes.

Costs: There is no cost to be in this study.

Estimated number of participants: 385 emerging adults who are deaf and hard of hearing

Funding source: The University of Wisconsin- Milwaukee School of Education

Where will data be stored? The anonymous data will be stored on the online survey servers (Qualtrics) for 30 days. Then only in the researchers' password protected digital file. Data will be saved for 7 years.

Who can see my data?

-The researchers can see your anonymous answers. The results will be presented in group analyses only.

-Agencies that enforce legal and ethical guidelines (such as the Institutional Review Board (IRB) at UWM or the Office for Human Research Protections (OHRP)) could see your anonymous data.

Questions, complaints, or problems regarding this research: Contact Macrae Husting at mhusting@uwm.edu.

Questions about your rights as a research participant: Contact the UWM IRB (Institutional Review Board) at 414-229-3173 or irbinfo@uwm.edu.

Please print or save this screen if you want to be able to access the information later. (IRB #: 18.304, IRB Approval Date: 6/21/2018)

Agreement to Participate

Participation is completely voluntary. You can withdraw at any time. If you would like to take the survey, give your consent below.

- I consent. Start the survey.
- I do not consent.

Appendix B

Survey Items regarding Sociodemographic Characteristics

Table 23

Sociodemographic Survey Items and Response Values

Item	Response Values
Survey inclusion criteria	
Are you 18-25 years old?	Yes No
Are you from the United States?	Yes No
Are you deaf or hard of hearing?	Yes No
Demographic Characteristics	
Age: How old are you (in years)?	String; 18-25
Gender: What is your gender identification?	1 = Male 2 = Female 3 = Another
Ethnicity: What is your race/ethnicity?	1 = White 2 = Asian/Asian American 3 = Hispanic/Latino/Latina/Latinx 4 = Black/African American 5 = American Indian/Alaska Native 6 = other (string) or multiracial/ethnic
Education to date: How far did you go in school (so far)?	1 = Did not complete HS (dropped out) 2 = Currently enrolled in or completed HS 3 = Some college 4 = Completed bachelor's degree 5 = Completed master's degree or higher

Hearing/Language-Related Characteristics

Self-Label Choice: How do you describe yourself?	<p>1= Hearing</p> <p>2= Deaf</p> <p>3= Hard of hearing</p> <p>4= Hearing impaired</p> <p>5= Other (string)</p>
Degree of Hearing Loss: What is your degree of hearing loss?	<p>1 = Normal - slight (-10-25 dB loss)</p> <p>2 = Mild (26-40 dB loss)</p> <p>3 = Moderate (41-55 dB loss)</p> <p>4 = Moderately severe (56-70 dB loss)</p> <p>5 = Severe (71-90 dB loss)</p> <p>6 = Profound (91+ dB loss)</p> <p>7 = I don't know</p>
Age at Identification: How old were you when your hearing loss was identified?	<p>1 = 0-1 years old</p> <p>2 = 2-3 years old</p> <p>3 = 4-10 years old</p> <p>4 = 11+ years old</p>
Device Usage: Do you use any of these? e	<p>1 = None</p> <p>2 = Hearing aid(s)</p> <p>3 = Cochlear implant(s)</p> <p>4 = Other (string)</p>
How do you prefer to communicate?	<p>1 = Spoken English</p> <p>2 = Other spoken language</p> <p>3 = American Sign Language (ASL)</p> <p>4 = Other sign language (SEE, MCE, TC, Sim. Com, PSE, Cued-Speech)</p>
How would you rate your level of reading and understanding written English?	<p>1 = Low</p> <p>2 = Medium</p> <p>3 = High</p>
At what age did you learn to sign?	<p>1 = I do not know ASL</p> <p>2 = 0-4 years old</p> <p>3 = 5-10 years old</p>

4 = 11-17 years old

5 = 18 or older

Family Characteristics

Parents' Hearing Status: Which best describes your parents?

1 = My parents are hearing

2 = One of my parents is deaf or hard of hearing

3 = More than one of my parents are deaf or hard of hearing

Parents' Ability to Sign: While you were growing up, did your parent(s) use sign language?

1 = No, none of my parents signed

2 = Yes, one of my parents signed

3 = Yes, more than one of my parents signed

Family Composition: For the majority of your childhood, who did you live with most?

1 = One parent

2 = Two parents, in same house

3 = More than one parent, in separate houses

4 = Other caregiver(s)

School Characteristics

For the next few questions, think about what your school was like most often growing up.

Education Type: What best describes your classroom?

1 = Mainstream or inclusive classroom with hearing students

2 = Special education classroom

3 = Classroom for deaf and hard of hearing students in public school

4 = School for the deaf (day student or residential)

Language of Instruction: What language was used to teach you?

1 = Spoken English (oral)

2 = Other spoken language

3 = American sign language

4 = Other sign language (SEE, MCE, TC, Sim. Com., PSE, Cued-Speech)

Peers in Classroom: How many other deaf	1 = 0
or hard of hearing students were in your	2 = 1-5
classroom?	3 = more than 5

Survey Closing Items

In closing the survey, participants were given the opportunity to clarify or comment on the survey with the following two open-ended, optional questions: “Do you want to clarify any of your answers? If yes, do so here.” And “Was anything on the survey confusing to you? If so, please let us know here.”

Appendix C

The Deaf Cultural Socialization Scale

Table 24

Items of the Verbal and Nonverbal Subscales of Deaf Cultural Socialization Scale (Husting, in progress) Side-by-Side the Original Items from the Family Ethnic Socialization Measure (Umaña-Taylor et al., 2004a)

Family Ethnic Socialization Measure (FESM)	Deaf Cultural Socialization Scale (DCSS)
Overt Socialization Subscale	Verbal Socialization Subscale
My family teaches me about my ethnic/cultural background.	My family taught me about the Deaf culture.
My family encourages me to respect the cultural values and beliefs of our ethnic/cultural background.	My family encouraged me to respect the cultural values and beliefs of the Deaf culture.
My family teaches me about the values and beliefs of our ethnic/cultural background.	My family taught me about the values and beliefs of the Deaf culture.
My family talks about how important it is to know about my ethnic/cultural background.	My family talked about how important it is to know about the Deaf culture.
My family teaches me about the history of my ethnic/cultural background.	My family taught me about Deaf history.
	My parent(s) taught me to be proud to be deaf.
	My parent(s) talked openly about deafness.
	My parent(s) encouraged me to have deaf friends.
	My parent(s) talked to me about the value of American Sign Language.
	My parent(s) talked to me about the value of the Deaf community.
Covert Socialization Subscale	Nonverbal Socialization Subscale
My family participates in activities that are specific to my ethnic group.	My family participated in Deaf cultural activities.
Our home is decorated with things that reflect my ethnic/cultural background.	Our home was decorated with things that reflected the Deaf culture.
The people who my family hangs out with the most are people who share the same ethnic background as my family.	The people who my family hung out with the most were people who share the Deaf cultural background.

My family celebrates holidays that are specific to my ethnic/cultural background.
My family listens to music sung or played by artists from my ethnic/cultural background.
My family attends things such as concerts, plays, festivals, or other events that represent my ethnic/cultural background.
My family feels a strong attachment to our ethnic/cultural background.

My family participated in events that celebrated Deaf culture (like Deaf Awareness week or culture festivals).
My family enjoyed music, dance, or storytelling by Deaf performers.
My family attended things such as concerts, plays, festivals, or other events that represent the Deaf culture.
My family felt a strong attachment to the Deaf culture.
My parent(s) used sign language around me.
My parent(s) exposed me to deaf adults.
My parent(s) took me places to meet other deaf people.

The Deaf Cultural Socialization Scale (DCSS) was developed for this study (see Development of a Scale section in Chapter 2) to measure the extent to which emerging adults report that their parents socialized them regarding the Deaf culture. The 20-item scale can be divided into two subscales that delineate two modes of transmission: verbal and nonverbal socialization.

The *Verbal* subscale (10 items; e.g., “My family teaches me about the history of my ethnic/cultural background.”) assesses direct verbal instruction and intentional efforts to socialize regarding the Deaf culture, such as messages related to promoting Deaf Pride, Deaf community membership, and the value of American Sign Language through direct verbal instruction and messages.

The *Nonverbal* subscale (10 items; e.g., “My parent(s) exposed me to deaf adults.”) assesses nonverbal socialization related to connecting with the Deaf community via their shared language and mentors through parental modeling and choice of activities.

The instructions on the survey indicated that when items refer to “parent(s),” participants should “think about whomever your primary caregiver(s) were” and to think about what they “said and did while you were growing up.” Participants rated their agreement with the items based on a 5-point Likert scale from 1 (*not at all true*) to 5 (*very much true*). The DCSS was scored as a total score, but could also provide separate subscale scores for the modes of transmission (i.e., Verbal and Nonverbal) in future studies. Higher scores indicate more perceived Deaf cultural socialization. Cronbach’s α was .97 for the total scale and .94 and .94 for the Verbal and Nonverbal subscales, respectively. The readability of the Deaf Cultural Socialization Scale was rated as grade level 6.8.

Follow-up questions. After the DCSS and MSS items were presented, follow-up items asked the following questions to guide future study development.

Developmental. “Think about the previous questions about what your parent(s) said and did to teach you what it means to be deaf or hard of hearing. Please rate how much they said and did when you were in the following grades:” elementary school (Kindergarten-5th grade), middle school (6th-8th grade), and high school (9th-12th grade). Participants rated each school level on a 5-point Likert scale from 1 (*none*) to 5 (*very much*).

Agent of socialization. Who said and did the most to teach you what it means to be deaf or hard of hearing? Participants made a forced choice of either *mother*, *father*, or *other caregiver*.

Other. Did your parent(s) say or do anything else that influenced what being deaf or hard of hearing means to you? If so, please explain. If not, leave blank.

Appendix D

The Minority Status Socialization Scale

Table 25

Items of the Minority Status Socialization Scale (MSS; Husting, in progress)

My parent(s) warned me that I might be treated badly because I am deaf.
My parent(s) talked to me about how to handle discrimination.
My parent(s) taught me to stand up for my accessibility needs.
My parent(s) told me to stand up for the rights of the Deaf community.
My parent(s) taught me about my rights as a deaf or hard or hearing person (laws).
My parent(s) warned me to not trust hearing people. (Deleted item.)

The Minority Status Socialization Scale (MSS; Husting, in progress) was developed for this study to measure the degree to which parents transmit messages about discrimination and how to cope with or overcome such difficulties associated with being a member of a minoritized group.

Participants rate their agreement with the six items based on a 5-point Likert scale from 1 (*not at all true*) to 5 (*very much true*). Higher scores on the MSS indicate more perceived minority status socialization. Cronbach's α was .849.

The readability of the Minority Status Socialization Scale was rated as grade level 5.6.

Appendix E

The Deaf Acculturation Scale (Maxwell-McCaw & Zea, 2011)

Table 26

The Deaf Acculturation Scale (Maxwell-McCaw & Zea, 2011)

The Deaf Culture Scale	The Hearing Culture Scale
Deaf Cultural Identification	Hearing Cultural Identification
I call myself deaf.	I call myself hearing impaired or hard of hearing.
I feel that I am part of the deaf community.	I feel that I am part of the hearing world.
I am comfortable with deaf people.	I am comfortable with hearing people.
Being involved in the deaf world (and with deaf people) is an important part of my life.	Being involved in the hearing world (and with hearing people) is an important part of my life.
My deaf identity is an important part of who I am.	I often wish I could hear better or become hearing.
Deaf Cultural Involvement	Hearing Cultural Involvement
How much do you enjoy	How much do you enjoy
Reading magazines/books written by deaf authors.	Socializing with hearing people.
Going to deaf events/parties/gatherings	Attending hearing gatherings/events/parties
Going to theater events with deaf actresses/actors	Going to theater events with hearing actresses/actors
Watching ASL videotapes by deaf storytellers or deaf poets.	Participating in or attending athletic hearing competitions.
Participating in political activities that promote the rights of deaf people.	Participating in hearing political activities.
Attending Deaf-related workshops (e.g., workshops on Deaf culture or linguistics in ASL)	Attending professional workshops in the hearing world.
Deaf Cultural Preferences	Hearing Cultural Preferences
If you could have your way, how would you prefer the following situations in your life to be like?	
I would prefer my education to be at a deaf school.	I would prefer my education to be at a hearing school or a mainstream environment.
I would prefer if my roommate was deaf.	I would prefer if my roommate was hearing.

I would prefer that my church/temple is mostly deaf.	I would prefer that my church/temple is mostly hearing.
I would prefer my date/partner/spouse to be deaf.	I would prefer my date/partner/spouse to be hearing.
I would prefer my closest friends to be deaf.	I would prefer my closest friends to be hearing.
I would prefer my children to be deaf.	I would prefer my children to be hearing.
I would prefer my work environment to be deaf.	I would prefer my work environment to be hearing.
Deaf Cultural Competence/Knowledge	Hearing Cultural Competence/Knowledge
How well do you know	How well do you know
Traditions and customs from Deaf schools.	Names of famous hearing actors and actresses.
Names of deaf heroes or well-known deaf people.	Names of national heroes.
Important events in Deaf history.	Important events in American/world history.
Well-known political leaders in the Deaf community.	Names of famous hearing political leaders.
Organizations run by and for Deaf people.	Names of popular hearing newspapers and magazines.
Deaf Language Competence (ASL)	Hearing Language Competence (English)
How well do you sign using ASL?	How well do you speak English, using your voice?
How well do you understand other people using ASL?	How well do you lipread?
When you sign using ASL, how well do other deaf people understand you?	In general, how well do hearing people understand your speech?
How well do you fingerspell?	How well do you write in English?
How well can you read other people's finger spelling?	How well can you read English?
How well do you know current ASL slang or popular expressions in ASL?	How well do you know English idioms or English expressions?

The Deaf Acculturation Scale (DAS; Maxwell-McCaw & Zea, 2011) measures cultural identity and acculturation among deaf and hard of hearing populations (Leigh et al., 2009; Maxwell-McCaw et al., 2000; Maxwell-McCaw & Zea, 2011). Two parallel scales measure the

degree of Deaf acculturation and Hearing acculturation, respectively, based on cultural behaviors, attitudes, psychological identification, and cultural competence. The two parallel cultural scales each contain 29 items, each rated on a 5-point Likert scale ranging from 1 (*strongly disagree or not at all*) to 5 (*strongly agree, a great deal, or excellent/like a native*). Degree of acculturation is reported as the average score on a cultural scale (i.e., ranging from 1-5), where higher scores indicated greater degree of acculturation.

The DAS can also be used to provide a snapshot of cultural identity status (Marschark et al., 2017). The average score on each cultural scale is categorized as low or high based on a mathematical median-split (i.e., the scale value of three; Maxwell-McCaw, 2001) and used to create four cultural identity statuses: Marginal (below the median in both Deaf and Hearing Acculturation), Hearing (below the median in Deaf Acculturation and above the median in Hearing Acculturation), Deaf (above the median in Deaf Acculturation and below the median in Hearing Acculturation), and Bicultural (above the median in both Deaf and Hearing Acculturation).

Maxwell-McCaw (2001) reported Cronbach's alpha of .96 and .91 for the Deaf Culture scale and the Hearing Culture scale, respectively.

The readability of the Deaf Acculturation Scale was rated as grade level 5.9.

Appendix F

The Rosenberg Self-Esteem Scale

Table 27

Items of the Rosenberg Self-Esteem Scale (1989)

-
- I am able to do things as well as most other people.
- I feel I do not have much to be proud of.
- I certainly feel useless at times.
- I feel that I'm a person of worth, at least on an equal plane with others.
- I wish I could have more respect for myself.
- All in all, I am inclined to feel that I am a failure.
- I take a positive attitude toward myself.
-

The Rosenberg Self-Esteem Scale (1989) assesses global, personal self-esteem with ten items that are rated on a 4-point scale ranging from 1 (*strongly disagree*) to 4 (*strongly agree*). Higher scores indicate more positive self-esteem. This scale has previously demonstrated high Cronbach's alpha of .82 with a deaf sample (Hintermair, 2008).

The readability of the Rosenberg Self-Esteem scale was rated as grade level 3.1.

Appendix G

The Satisfaction with Life Scale

Table 28

Items of the Satisfaction with Life Scale (Diener et al., 1985)

In most ways my life is close to my ideal.

The conditions of my life are excellent.

I am satisfied with my life.

So far I have gotten the important things I want in life.

If I could live my life over, I would change almost nothing.

The Satisfaction with Life Scale (Diener, Emmons, Larsen, & Griffin, 1985) has been used to assess subjective well-being globally in previous studies with deaf and hard of hearing samples (Hintermair, 2008; Maxwell-McCaw, 2001). The scale consists of 5 items that are rated on a 7-point Likert scale ranging from 1 (*strongly disagree*) to 7 (*strongly agree*). Higher scores indicate greater satisfaction. Diener et al. (1985) originally reported a coefficient alpha of .87. Studies using the scale with the Deaf population have reported coefficient alphas of .86 and .87 (Hintermair, 2008; Maxwell-McCaw, 2001).

The readability of the Satisfaction with Life Scale was rated as grade level 3.1.

Appendix H

The Patient Health Questionnaire

Table 29

Items of the Patient Health Questionnaire (PHQ-4; Kroenke, Spitzer, Williams, & Löwe, 2009)

Over the last 2 weeks, how often have you been bothered by the following problems?

Feeling nervous, anxious, or on edge

Not being able to stop or control worrying

Feeling down, depressed, or hopeless

Little interest or pleasure in doing things

The Patient Health Questionnaire (PHQ-4; Kroenke, Spitzer, Williams, & Löwe, 2009) assesses depression and anxiety. Higher scores indicate more depression and anxiety. Kroenke et al. (2009) reported Cronbach's alpha of .85.

The readability of the Patient Health Questionnaire was rated as grade level 6.7.

Appendix I

The Remembered Relationship with Parents Scale

Table 30

Items of the Remembered Relationship with Parents (Denollet et al., 2007)

Alienation	Control
I was very closed towards my parents.	I wished my parents would worry less about me.
I kept my troubles to myself (towards my parents).	My parents' anxiety that something might happen to me was exaggerated.
My parents often made me feel insecure.	My parents worried that I couldn't take care of myself.
My parents often made me feel guilty.	My parents sheltered me too much from difficulties.
I often felt that my parents did not understand me.	My parents were overprotective.

The Remembered Relationships with Parents Scale (RRPS; Denollet, Smolderen, van den Broek, & Pedersen, 2007) is a 10-item retrospective self-report scale that assesses the parent-child relationship while growing up across two domains of empathic parenting: Alienation and Control. The *Alienation* subscale (5 items) assesses the degree to which the reporter felt alienated from their parents growing up. The *Control* subscale (5 items) assesses the degree to which the reporter remembers their parents being controlling and overprotective.

Items are rated on a 5-point Likert scale ranging from 1 (*false*) to 5 (*true*). Higher scores on either subscale reflect memories of more negative relationships (i.e., more controlling or more alienating). In the original study, the two subscales were moderately correlated ($r=.38$) and Cronbach's alphas for the Alienation and Control subscales were .83 and .86, respectively (Denollet et al., 2007). The readability of the Remembered Relationship with Parents Scale was rated as grade level 5.7.

Appendix J

Exploration of the Modes of Transmission

The Factor analyses presented in the Results chapter did not support the distinction of Verbal and Nonverbal subscales with the current sample. However, some descriptive results are here presented to explore the potential nuances of modes of transmission and parent hearing status to inform future study design.

Table 31 presents the means and group differences in engagement in Verbal and Nonverbal socialization across parents' hearing status. Parents' hearing status is here dichotomized as having one or more deaf or hard of hearing parent(s) (Deaf of Deaf; DoD) or having only hearing parents (Deaf of Hearing; DoH) because the sample size is so small for those with two or more deaf or hard of hearing parents. Deaf of Deaf did not differ from Deaf of Hearing in Verbal DCSS. Group difference emerged for Nonverbal DCSS, with Deaf of Deaf reporting more Nonverbal DCSS than the Deaf of Hearing. (The difference in Nonverbal is not significant when parents' hearing status is trichotomized).

Table 31
Summary of Descriptive and ANOVA Results for Verbal and Nonverbal Deaf Cultural Socialization Across Parents' Hearing Status Groups

	<i>N</i>	<i>M</i>	<i>SD</i>	<i>F</i>	<i>p</i>
Verbal DCSS					
Deaf of Deaf	71	3.20	1.11	2.40	.123
Deaf of Hearing	234	2.95	1.21		
Total	305	3.01	1.19		
Nonverbal DCSS					
Deaf of Deaf	71	2.90	1.04	5.50 ^a	.021*
Deaf of Hearing	234	2.56	1.17		
Total	305	2.64	1.15		

Note. ^aHomogeneity of variance is violated; Welch F reported. * $p < .05$

Correlations between study variables. Table 32 presents a summary of the correlations between Verbal and Nonverbal DCSS and the other study variables. These results are reported separately for the Deaf of Deaf, the Deaf of Hearing, and the total sample to explore potential nuances.

Table 32

Summary of Correlations between Verbal DCSS, Nonverbal DCSS, and the Study Variables for the Deaf of Deaf (DoD; N=71), Deaf of Hearing (DoH; N=234), and the Total Sample (N=305)

	Verbal DCSS			Nonverbal DCSS		
	DoD	DoH	Total	DoD	DoH	Total
Verbal DCSS	1	1	1	.89**	.91**	.90**
Nonverbal DCSS	.89**	.91**	.90**	1	1	1
Deaf Acculturation	.80**	.75**	.76**	.80**	.78**	.79**
Hearing Acculturation	.27*	.06	.10	.17	.02	.04
Self-Esteem	.14	.28**	.24**	.18	.24**	.21**
Satisfaction with Life	.23	.42**	.38**	.23*	.41**	.37**
Depression/Anxiety	.30*	-.11	-.02	.20	-.08	-.02
Control	.33**	.21**	.24**	.29*	.20**	.22**
Alienation	.10	-.06	-.02	.08	.00	.02

Note. * $p < .05$; ** $p < .001$

The table demonstrates that Verbal and Nonverbal DCSS were highly correlated ($r = .89-.91$). Regardless of parents' hearing status, both Verbal and Nonverbal DCSS were significantly correlated with Deaf Acculturation and Control, but not Alienation. The results were more nuanced for Hearing Acculturation, Self-Esteem, and Satisfaction with Life. Verbal DCSS was correlated with Hearing Acculturation for the Deaf of Deaf only. Nonverbal DCSS was not correlated with Hearing Acculturation. Verbal and Nonverbal DCSS were correlated with Self-Esteem for the Deaf of Hearing, but not the Deaf of Deaf. Satisfaction with Life was correlated with both Verbal and Nonverbal DCSS for the Deaf of Hearing, but only Nonverbal DCSS for the Deaf of Deaf.

While the Deaf of Deaf and Deaf of Hearing groups did not differ in the degree of Verbal DCSS reported, the significance test of the correlations differed between Verbal DCSS and four outcome variables across these two groups. The significance tests of the correlations between Nonverbal DCSS and only one of the outcome variables differed (i.e., self-esteem). This is a somewhat surprising finding as the effect of nonverbal socialization might be expected to vary between these groups. The Nonverbal scale was developed based on the Covert subscale of the Family Ethnic Socialization Measure. As explained in the Scale Construction section, this scale was renamed Nonverbal for this dissertation because of issues with intent. Ethnic minority families and multigenerational Deaf families likely engage in covert socialization by living their daily lives in the manner typical to their own cultural identity. They are unintentionally transmitting messages about the meaning and importance of their culture by simply living it. However, the majority of parents of deaf and hard of hearing children are not culturally Deaf. Therefore, these parents' efforts to model and engage in Deaf cultural behaviors likely involves intention. They are likely purposefully exposing the child to the Deaf culture in order to promote Deaf identity development. The intention behind a behavior is notably different for Deaf parents and hearing parents, therefore, nonverbal DCSS might be expected to display a different association with outcomes across the groups.

Even in the ethnic-racial literature, there has been minimal research done on the effects of different modes of transmitting socialization messages, so these preliminary findings suggest that additional research is needed to develop a more reliable measure of the modes of transmission and to explore how parents' hearing status may interact with the expression and intent of their socialization practices.

Appendix K

Cultural Identity Statuses and Study Variables

Table 33 presents a summary of descriptive statistics and ANOVA results of the study variables across the cultural identity statuses of the Deaf Acculturation Scale. Cultural identity was calculated with the scale's mathematical median split value of 3.

Table 33
Descriptive Statistics and ANOVA Results of Each of the Study Variables across Cultural Identity Statuses

	<i>N</i>	<i>M</i>	<i>SD</i>	<i>F</i>	<i>p</i>	Marginal	Hearing	Deaf
DCSS				67.59 ^a	.000**			
Marginal	32	2.16	.99					
Hearing	126	2.12	.94			.997		
Deaf	16	3.34	.58			.000**	.000**	
Bicultural	131	3.60	.83			.000**	.000**	.376
MSS				41.01 ^a	.000**			
Marginal	31	2.26	.94					
Hearing	126	2.65	1.19			.224		
Deaf	11	3.56	.65			.000**	.000**	
Bicultural	129	3.82	.85			.000**	.000**	.511
Self-Esteem				4.25 ^a	.009*			
Marginal	32	2.48	.46					
Hearing	126	2.54	.60			.932		
Deaf	16	2.47	.39			1.00	.921	
Bicultural	131	2.72	.49			.056	.042*	.117
Satisfaction with Life				13.21	.000**			
Marginal	32	3.51	1.27					
Hearing	126	3.90	1.36			.443		
Deaf	16	3.84	.80			.854	.998	
Bicultural	131	4.77	1.35			.000**	.000**	.043*
Depression/Anxiety				.56 ^a	.642			
Marginal	32	2.34	.69					
Hearing	126	2.48	1.01					
Deaf	16	2.56	.69					
Bicultural	131	2.52	.83					

Parent-Child:				3.68	.013*			
Control								
Marginal	32	2.86	1.01					
Hearing	126	3.02	.94		.782			
Deaf	16	3.14	.63		.725	.959		
Bicultural	131	3.32	.81		.040*	.035*	.864	
Parent-Child:				1.20	.309			
Alienation								
Marginal	32	2.75	1.10					
Hearing	126	2.96	1.06					
Deaf	16	3.10	.68					
Bicultural	131	3.11	1.00					

Note. ^aAssumption of homogeneity of variance is violated; Welch F and Games-Howell reported. $p < .001$

Group differences emerged for DCSS, MSS, self-esteem, satisfaction with life, and control.

DCSS and MSS. Post hoc analyses indicated that participants with Marginal identities scored significantly lower on the DCSS and MSS than those with Deaf and Bicultural identities. Participants with Hearing identities also scored significantly lower on the DCSS and MSS than those with Deaf and Bicultural identities. There was no difference between those with Marginal and Hearing identities, nor between those with Deaf and Bicultural identities for either measure.

Self-esteem. Post hoc analyses indicated that participants with Bicultural identity had higher self-esteem than those with Hearing identity.

Satisfaction with life. Post hoc analyses indicated that participants who had Bicultural identity had higher satisfaction with life than those with Marginal, Hearing, or Deaf identities.

Control. Post hoc analyses indicated that participants who had Bicultural identity remembered their parents as more controlling than those with Marginal or Hearing identities.

Appendix L

Parents' Hearing Status Dichotomized and Study Variables

Table 34 presents the results of a series of ANOVAs of all of the study variables across parents' hearing status, which was dichotomized as either 1) hearing parents only and 2) one or more deaf or hard of hearing parent(s). Group differences only emerged for Deaf cultural socialization, with those with hearing parents reporting less DCSS. Parent hearing status groups did not differ in DCSS when trichotomized in the Results chapter. The group differences in self-esteem reported in the trichotomized Results chapter did not emerge when parents' hearing status was dichotomized. Group differences in Deaf acculturation just missed the level of significance when parents' hearing status was dichotomized ($F=3.83, p=.051$), but not when trichotomized ($F=2.02, p=.135$). This marginality should temper the interpretation of these results until findings are replicated.

Table 34
Summary of Analysis of Variance Results of Group Differences in Study Variables by Parents' Hearing Status Dichotomized

	<i>M</i>	<i>SD</i>	<i>F</i>	<i>p</i>
DCSS			4.12a	.044*
Hearing Parents Only	2.75	1.16		
1+ D/HH Parents	3.05	1.04		
Total	2.82	1.14		
MSS			2.56	.111
Hearing Parents Only	3.09	1.19		
1+ D/HH Parents	3.35	1.14		
Total	3.15	1.18		
Deaf Acculturation			3.83	.051
Hearing Parents Only	2.78	.91		
1+ D/HH Parents	3.03	.82		
Total	2.83	.89		
Hearing Acculturation			.95	.330
Hearing Parents Only	3.60	.68		
1+ D/HH Parents	3.51	.68		
Total	3.58	.68		
Self-Esteem			3.26	.072

Hearing Parents Only	2.64	.55		
1+ D/HH Parents	2.51	.51		
Total	2.61	.54		
Satisfaction with Life			.03	.870
Hearing Parents Only	4.22	1.43		
1+ D/HH Parents	4.25	1.33		
Total	4.23	1.40		
Depression/Anxiety			.22	.644
Hearing Parents Only	2.47	.91		
1+ D/HH Parents	2.53	.83		
Total	2.49	.89		
Control			1.14	.287
Hearing Parents Only	3.11	.91		
1+ D/HH Parents	3.24	.83		
Total	3.14	.89		
Alienation			.16	.693
Hearing Parents Only	3.00	1.04		
1+ D/HH Parents	3.05	.97		
Total	3.01	1.02		

Note. Sample sizes for levels of Parents' Hearing Status: hearing parents only n=234, one or more deaf or hard of hearing parent n=71. *p<.05

Appendix M

Post Hoc Comparisons of Group Differences in DCSS and MSS

Post hoc comparisons of group differences in DCSS and MSS across the sociodemographic variables are presented below.

Demographic Characteristics. There were no significant differences in DCSS or MSS based on demographic characteristics (see Table 13).

Hearing/Language-Related Characteristics. There were significant differences in DCSS and MSS based on all of the hearing/language-related characteristics, except English literacy (see Table 13). Welch F and Games-Howell post hocs are reported when the assumption of homogeneity of variance of the means was violated.

There was a significant main effect of self-label for DCSS ($F_{4, 300}=4.12, p=.003$) and MSS ($F_{4, 296}=3.03, p=.018$). Tukey post hoc analyses indicated those who self-label as “Deaf” scored higher than those who self-label as “Hard of Hearing” (Mean Diff=.72, $SE=.21, p=.005$, and Mean Diff=.71, $SE=.22, p=.013$, respectively) and “Hearing Impaired” (Mean Diff=.90, $SE=.24, p=.002$, and Mean Diff=.73, $SE=.26, p=.040$, respectively).

There was a significant main effect of degree of hearing loss for DCSS ($F_{5, 299}=6.12, p=.000$) and MSS ($F_{5, 295}=5.86, p=.000$). Tukey post hoc analyses indicated those with Mild hearing loss scored lower than those with Moderate (DCSS Mean Diff=-.53, $SE=.15, p=.009$, and MSS Mean Diff=-.47, $SE=.16, p=.044$) and Moderately-Severe hearing loss (DCSS Mean Diff=-.85, $SE=.18, p=.000$, and MSS Mean Diff=-.82, $SE=.20, p=.001$). Those who did not know the degree of their hearing loss scored lower than those with Moderate (DCSS Mean Diff=-.69,

$SE=.23, p=.037$, and MSS Mean Diff=-.75, $SE=.24, p=.039$) and Moderately Severe hearing loss (DCSS Mean Diff=-1.02, $SE=.26, p=.001$, and MSS Mean Diff=-1.06, $SE=.27, p=.001$).

There was a significant main effect of age at identification for DCSS (Welch $F_{3, 116.5}=6.48, p=.000$) and MSS (Welch $F_{3, 113.3}=4.89, p=.003$). Games-Howell post hoc analyses indicated those identified at age 2-3 scored higher than those identified at age 11 or older (DCSS Mean Diff=.73, $SE=.17, p=.000$ and MSS Mean Diff=.68, $SE=.18, p=.001$).

There was a significant main effect of device for DCSS ($F_{3, 301}=19.65, p=.000$) and MSS (Welch $F_{2, 61}=22.84, p=.000$). Post hoc analyses indicated that those who used no device scored lower than those who used a hearing aid (DCSS Mean Diff=-.92, $SE=.13, p=.000$, and MSS Mean Diff=-.83, $SE=.13, p=.000$) or cochlear implants (DCSS Mean Diff=-1.14, $SE=.25, p=.000$, and MSS Mean Diff=-1.17, $SE=.26, p=.000$).

There was a significant main effect of preferred communication for DCSS (Welch $F_{3, 15.4}=1.50, p=.001$) and MSS (Welch $F_{3, 14.1}=7.97, p=.002$). Games-Howell post hoc analyses indicated those who preferred to communicate with spoken English scored lower than those who preferred to ASL (DCSS Mean Diff=-.84, $SE=.15, p=.000$, and MSS Mean Diff=-.71, $SE=.15, p=.000$).

There was a significant difference between those who did and did not know ASL for DCSS ($F=90.42, p=.000$) and MSS ($F=61.84, p=.000$). There was a significant main effect of Age of Learning (for those who know ASL) for DCSS (Welch $F_{3, 70.3}=7.66, p=.000$) and MSS (Welch $F_{3, 71.2}=7.48, p=.000$). Games-Howell post hoc analyses indicated those who learned ASL at age 0-4 scored higher than those who learned at age 11-17 (DCSS Mean Diff=.77, $SE=.19, p=.001$ and MSS Mean Diff=.72, $SE=.19, p=.001$) and 18 and above (DCSS Mean

Diff=1.00, $SE=.29$, $p=.009$ and MSS Mean Diff=1.13, $SE=.29$, $p=.003$). Those who learned ASL at age 5-10 scored higher in DCSS than those who learned at 11-17 (DCSS Mean Diff=.51, $SE=.17$, $p=.015$) and higher in MSS than those who learned at 18 or above (MSS Mean Diff=.79, $SE=.28$, $p=.042$).

Family Characteristics. There was a significant main effect of parents' ability to sign for DCSS (Welch $F_{2, 142.8}=54.17$, $p=.000$) and MSS (Welch $F_{2, 141.4}=35.05$, $p=.000$). Games-Howell post hoc analyses indicate that those whose parents did not sign scored lower than those who had one (DCSS Mean Diff=-1.03, $SE=.13$, $p=.000$ and MSS Mean Diff=-.82, $SE=.14$, $p=.000$) or two or more parents who could sign (DCSS Mean Diff=-1.30, $SE=.14$, $p=.000$ and MSS Mean Diff=-1.19, $SE=.15$, $p=.000$). For MSS, the difference between having one and two or more parents that could sign approached significance (MSS Mean Diff=-.38, $SE=.16$, $p=.055$).

School Characteristics. There was a significant main effect of classroom type for DCSS (Welch $F_{3, 30.4}=10.42$, $p=.000$) and MSS (Welch $F_{3, 30.3}=8.25$, $p=.000$). Games-Howell post hoc analyses indicate that those who were in mainstream classrooms scored significantly lower on the DCSS than those in a special education classroom (Mean Diff=-.52, $SE=.16$, $p=.009$) or a classroom for the deaf and hard of hearing (Mean Diff=-.81, $SE=.16$, $p=.000$). Those who were in classrooms for the deaf and hard of hearing scored significantly higher on the MSS than those in a mainstream classroom (Mean Diff=.79, $SE=.16$, $p=.000$) or a special education classroom (Mean Diff=.56, $SE=.16$, $p=.021$).

There was a significant main effect of language of instruction for DCSS (Welch $F_{3, 34.6}=13.58$, $p=.000$) and MSS (Welch $F_{3, 28.5}=5.88$, $p=.003$). Games-Howell post hoc analyses indicate that those who were instructed in spoken English scored lower than those who were

instructed in ASL (DCSS Mean Diff=.94, $SE=.15$, $p=.000$ and MSS Mean Diff=-.68, $SE=.16$, $p=.000$) and other forms of sign language (DCSS Mean Diff=-.56, $SE=.16$, $p=.014$; no difference in MSS).

There was a significant main effect of deaf and hard of hearing peers for DCSS (Welch $F_{2, 58.2}=29.12$, $p=.000$) and MSS (Welch $F_{2, 54.9}=27.94$, $p=.000$). Games-Howell post hoc analyses indicate that those who had no deaf or hard of hearing peers in the classroom scored lower than those who had 1-5 (DCSS Mean Diff=-.87, $SE=.13$, $p=.000$ and MSS Mean Diff=-.96, $SE=.13$, $p=.000$) or 5 or more (DCSS Mean Diff=-1.22, $SE=.22$, $p=.000$ and MSS Mean Diff=-.99, $SE=.27$, $p=.003$) deaf or hard of hearing peers in the classroom.

Appendix N

Parents' Hearing Status as a Moderator

The potential moderating effect of parents' hearing status was explored preliminarily to determine if the association between socialization and outcome variables varied based on parents' hearing status. To test this, a multiple regression analysis was done for each of the outcome variables with socialization (i.e., DCSS or MSS; See Table 35), parents' hearing status, and a moderator term (i.e., centered, trichotomized parents' hearing status multiplied by centered DCSS or MSS) as predictors. Parents' hearing status did not moderate the association between Deaf cultural socialization and any of the outcome variables (except depression/anxiety, for which there were no main effects of DCSS or Parents hearing status).

Table 35

Summary of Multiple Regression Analyses Predicting the Outcome Variables with the Deaf Cultural Socialization Scale (DCSS), Parents' Hearing Status, and a Moderator Term

	Deaf		Hearing		Self-Esteem		Satisfaction with Life		Depression/Anxiety	
	Acculturation		Acculturation		Self-Esteem		with Life		Anxiety	
	β	<i>p</i>	β	<i>p</i>	β	<i>p</i>	β	<i>p</i>	β	<i>p</i>
DCSS	.79	.000**	.17	.004*	.24	.000**	.38	.000**	-.02	.789
Parents' hearing status	.03	.438	-.09	.127	-.16	.006*	-.04	.513	.05	.360
Moderator: DCSS*Parents' hearing status	.01	.826	.05	.410	-.05	.410	-.05	.327	.14	.019*
R^2	.632	.000**	.033	.018*	.080	.000**	.152	.000**	.023	.076

Note. DCSS and parents' hearing status variables were centered to avoid issues of multicollinearity before creating the moderator product term.

Table 36

Summary of Multiple Regression Analyses Predicting the Outcome Variables with the Minority Status Socialization Scale (MSS), Parents' Hearing Status, and a Moderator Term

	<i>Deaf</i>		<i>Hearing</i>		<i>Self-Esteem</i>		<i>Satisfaction with Life</i>		<i>Depression/Anxiety</i>	
	<i>Acculturation</i>		<i>Acculturation</i>		<i>Self-Esteem</i>		<i>Satisfaction with Life</i>		<i>Depression/Anxiety</i>	
	β	<i>p</i>	β	<i>p</i>	β	<i>p</i>	β	<i>p</i>	β	<i>p</i>
MSS	.70	.000**	.21	.000**	.215	.000**	.29	.000**	-.02	.682
Parents' hearing status	.06	.170	-.08	.156	-.15	.008*	-.02	.701	.06	.303
Moderator: MSS*Parents' hearing status	-.02	.562	.07	.214	-.12	.035*	-.06	.264	.18	.002*
R^2	.494	.000**	.050	.002*	.081	.000**	.088	.000**	.037	.011*

Note. MSS and parents' hearing status variables were centered to avoid issues of multicollinearity before creating the moderator product term.

Table 36 presents multiple regressions concerning the MSS. Parents' hearing status did moderate one association between minority status socialization and outcome variables (MSS $\beta=.22$, $p=.000$, parents' hearing status $\beta=-.15$, $p=.008$, Moderator term $\beta=-.12$, $p=.035$): MSS only predicted self-esteem for those with hearing parents ($\beta=.27$, $p=.000$). Increases in minority status socialization was not associated with increases in self-esteem for those with one ($\beta=.07$, $p=.588$) or two or more deaf or hard of hearing parents ($\beta=-.36$, $p=.311$).

Appendix O

Content Analysis of the Minority Status Socialization Scale

This appendix explores how distinct message content embedded in the MSS interacted with the other study variables for future scale development.

The original 6-item Minority Status Socialization Scale (MSS; Husting, in progress) included items that can be classified by content as relating to advocacy (3 items), preparation for bias (2 items), and promotion of mistrust (1 item). Table 37 presents the correlations between the average ratings for each of these three content classifications with the other study variables. Advocacy and preparation for bias were strongly correlated with each other, but weakly with promotion of mistrust. Promotion of mistrust had a moderate correlation with total DCSS, total MSS, and Deaf acculturation, weak correlations with satisfaction with life, control, and alienation, and was uncorrelated with Hearing acculturation, self-esteem, and depression/anxiety. Advocacy and preparation for bias both had strong correlations with total DCSS and total MSS scales, moderate to strong correlations with Deaf acculturation, weak correlations with Hearing acculturation, control, satisfaction with life and self-esteem (self-esteem correlated with advocacy only), and were uncorrelated with depression/anxiety and alienation.

The pattern of significant correlations was fairly consistent across the content classifications of MSS, with a few exceptions: Self-esteem was correlated with advocacy, but not preparation for bias and promotion of mistrust. Hearing acculturation was correlated with advocacy and preparation for bias, but not promotion of mistrust. Alienation was only correlated with promotion of mistrust.

Table 37

Summary of Bivariate Correlations Between MSS Items Categorized as Advocacy, Preparation for Bias, and Promotion of Mistrust and the Study Variables

	MSS Advocacy	MSS Prep. for Bias	MSS Prom. of Mistrust	
MSS- Advocacy	1	.77**	.32**	
MSS- Preparation for Bias	.77**	1	.33**	
MSS- Promotion of Mistrust	.32**	.33**	1	
DCSS- total	.85**	.73**	.51**	
MSS- total	.96**	.91**	.34**	
Deaf Acculturation	.68**	.62**	.47**	
Hearing Acculturation	.20**	.18**	.01	
Self-Esteem	.26**	.11	.01	
Satisfaction with Life	.34**	.17**	.18**	
Depression/Anxiety	-.07	.05	.05	
Control	.18**	.25**	.18**	
Alienation	-.06	.09	.25**	
	M	3.13	3.19	2.05
	SD	1.25	1.25	1.37

Note. Means are reported as scale averages rated on 5-point Likert scales, except Satisfaction with Life (7-point scale) and Depression/Anxiety and Self-Esteem (4-point scales). * $p < .05$; ** $p < .001$

Parental engagement in minority status socialization across the three content classifications is presented in Table 38. Parent hearing status groups did not differ in advocacy or preparation for bias messages. Group differences did emerge for the promotion of mistrust content. Post hoc Games-Howell identified that those with one deaf or hard of hearing parent reported more promotion of mistrust than those with hearing parents (Mean difference=.54, $p=.031$) and those with two or more deaf or hard of hearing parents (Mean difference=.94, $p=.043$).

Table 38
Summary of ANOVA Results of Group Differences in Parents' Hearing Status Across the Content of MSS Items

	M	SD	F	p
MSS- Advocacy			1.20	.302

0 D/HH Parents	3.08	1.27		
1 D/HH Parent	3.35	1.20		
2+ D/HH Parents	2.93	1.13		
Total	3.13	1.25		
MSS- Preparation for Bias			1.99	.139
0 D/HH Parents	3.11	1.26		
1 D/HH Parent	3.48	1.18		
2+ D/HH Parents	3.15	1.31		
Total	3.19	1.25		
MSS- Promotion of Mistrust			4.45 ^a	.024*
0 D/HH Parents	1.95	1.33		
1 D/HH Parent	2.49	1.50		
2+ D/HH Parents	1.56	.88		
Total	2.05	1.37		

Note. Means are reported as scale averages rated on 5-point Likert scale.

^aThe assumption of homogeneity of variance was violated; Levene statistic=4.45, $p=.012$; Welch F reported. * $p<.05$; ** $p<.001$

The mixed message content of the MSS items confounded the scale's psychometrics, as mentioned in the discussion section. Additional work is needed to better develop the MSS and its potential subscales. This should include developing additional items (particularly for the single-item promotion of mistrust content), exploring if advocacy is a separate construct or an aspect of preparation for bias, and exploring the unique contributions of each type of message content.

Appendix P

DCSS Items by Source and Mode of Transmission

Table 39 presents the correlations between the study variables and the adapted items of the Family Ethnic Socialization Measure (Umaña-Taylor et al., 2004b) and the Deaf-specific items added for this study (Husting, in progress), separately.

Table 39

Bivariate Correlations Among Study Variables and the Items Adapted from the FESM and the Additional Deaf-Specific Items

	FESM Items		Deaf-Specific Items	
	Verbal	Nonverbal	Verbal	Nonverbal
Deaf Acculturation	.73**	.76**	.76**	.76**
Hearing Acculturation	.08	.02	.12*	.09
Self-Esteem	.23**	.19**	.24**	.22**
Satisfaction with Life	.37**	.36**	.37**	.35**
Depression/Anxiety	-.03	-.03	-.02	-.01
M	2.96	2.58	3.06	2.77
SD	1.26	1.16	1.19	1.26

Note. The FESM Verbal and Nonverbal scales contain five and seven items, respectively. There are five and three additional Deaf-Specific Verbal and Nonverbal items, respectively.

Socialization items were strongly correlated with Deaf acculturation, moderately correlated with satisfaction with life, and weakly correlated with self-esteem regardless of the source of the items or the mode of transmission. The Verbal and Nonverbal scales of the FESM were not correlated with Hearing acculturation. For the additional Deaf-specific items, only the Verbal scale was correlated with Hearing acculturation.

These analyses identify that additional exploration into why socialization predicted Hearing acculturation in this study should begin by evaluating and potentially editing the additional, Deaf-specific Verbal items of the DCSS.

Appendix Q

School level and Primary Agent of Socialization

Follow-up Questions after Administering the Combined DCSS and MSS items

When the survey was administered, the original 26 socialization items were combined together (i.e., the 20 DCSS items, the 5 items retained in the MSS, and the deleted item of the MSS). Follow-up questions asked participants to reflect on the timing and the source of this total socialization. These items were not analyzed in the Results chapter due to the combination of the DCSS and MSS in administration. The descriptive results are here presented to inform future research development.

Socialization Across School Levels. After progressing through the original 26 socialization items, participants were instructed to “Think about the previous questions about what your parent(s) said and did to teach you what it means to be deaf or hard of hearing.” Participants then provided ratings on how much their parent(s) said and did on a 5-point scale, ranging from 1 (*none*) to 5 (*very much*) for each of the following levels of school: Elementary (Kindergarten-5th Grade), Middle School (6th-8th Grade), and High School (9th-12th Grade). Table 40 presents the descriptive information on the ratings for each school level, the correlations between school levels’ socialization scores, and tests of the paired comparisons of the means of the school levels.

Table 40
Comparison of Socialization (DCSS and MSS Combined) Reported Across School Levels: Descriptive Summary, Correlations, and Paired Comparisons

School	<i>M</i>	<i>SD</i>	Middle			High		
			<i>r</i>	<i>M Diff</i>	<i>t</i>	<i>r</i>	<i>M Diff</i>	<i>t</i>
Elementary	2.83	1.47	.66**	-.26	-3.80**	.46**	-.41	-4.64**

Middle	3.09	1.37	.71*	-.15	-2.41*
High	3.25	1.45			

Note. Mean and standard deviation reported on a 5-point scale

Socialization increased significantly with level of school. Socialization at each school level was moderately to strongly correlated with each of the other two school levels. The pattern of correlations between socialization and the outcome variables was stable across level of school (see Table 41), with moderate correlations with Deaf acculturation and satisfaction with life, weak correlations with self-esteem and control, and no correlations with Hearing acculturation, depression/anxiety, and alienation.

Table 41
Correlations Between Study Variables and Socialization Received at Each Level of School

	Level of School		
	Elementary	Middle	High
Deaf Acculturation	.53**	.57**	.59**
Hearing Acculturation	.09	.08	.05
Self-Esteem	.27*	.20**	.13*
Satisfaction with Life	.35**	.30**	.26**
Depression/Anxiety	-.06	-.04	.01
Control	.12*	.13*	.18**
Alienation	-.04	-.07	.00

Primary Agent of Socialization. After progressing through the original 26 socialization items, participants were asked, “Who said and did the most to teach you what it means to be deaf or hard of hearing?” Participants then selected one of the following options: Mother, Father, or Other Caregiver. Table 42 presents the results of some preliminary analyses that were omitted from the Results chapter due to the combining of DCSS and MSS.

Table 42
Summary of Analysis of Variance Results of Group Differences in Study Variables by Primary Agent of Socialization: Mother (N=210), Father (N=56), and Other Caregiver (N=37)

Tukey

	<i>M</i>	<i>SD</i>	<i>F</i>	<i>p</i>	Father	Other
DCSS			19.55	.000**		
Mother	2.94	1.10			.673	.000**
Father	3.07	1.04				.000**
Other Caregiver	1.79	1.00				
Total	2.82	1.14				
MSS			16.68	.000**		
Mother	3.30	1.15			.996	.000**
Father	3.29	1.09				.000**
Other Caregiver	2.15	1.08				
Total	3.15	1.19				
Deaf Acculturation			9.24	.000**		
Mother	2.89	.90			.876	.000**
Father	2.96	.80				.000**
Other Caregiver	2.25	.83				
Total	2.83	.89				
Hearing Acculturation			1.94	.145		
Mother	3.63	.64				
Father	3.51	.64				
Other Caregiver	3.42	.90				
Total	3.58	.68				
Self-Esteem			5.18	.006*		
Mother	2.66	.54			.687	.004*
Father	2.59	.48				.089
Other Caregiver	2.35	.57				
Total	2.61	.54				
Satisfaction with Life			6.57	.002*		
Mother	4.37	1.37			.541	.001*
Father	4.15	1.28				.060
Other Caregiver	3.49	1.57				
Total	4.22	1.41				
Depression/Anxiety			3.88	.022*		
Mother	2.41	.88			.845	.016*
Father	2.49	.86				.127
Other Caregiver	2.85	.93				
Total	2.48	.89				
Control			.013	.987		
Mother	3.13	.90				
Father	3.15	.78				
Other Caregiver	3.15	1.04				
Total	3.14	.89				
Alienation			3.64	.027*		
Mother	2.94	1.01			.964	.021*
Father	2.98	1.02				.096
Other Caregiver	3.43	1.06				
Total	3.01	1.03				

Note. Tukey Post-Hoc paired comparisons. * $p < .05$

Group differences emerged based on primary agent of socialization (i.e., mother, father, or other caregiver) for DCSS, MSS, Deaf acculturation, self-esteem, satisfaction with life, depression/anxiety, and alienation. Tukey post-hoc pairwise comparison identified that compared with those who selected “other caregiver”, those who selected “mother” as the primary agent of socialization reported higher DCSS, MSS, Deaf acculturation, self-esteem, and satisfaction with life, and lower depression/anxiety and alienation. Compared with those who selected “other caregiver,” those who selected “father” reported higher DCSS, MSS, and Deaf acculturation. There were no group differences between those who selected “mother” and those who selected “father.”

In summary, when the primary agent of socialization was “other caregiver,” participants reported receiving less socialization. Distinctions cannot be made between DCSS and MSS for any of these analyses, as they were combined in the survey. They were, therefore, excluded from the Results chapter. They are presented here to contribute to future study design.

CURRICULUM VITAE

Macrae Husting

Education

2012- Present. Ph.D. candidate, Educational Psychology, University of Wisconsin-Milwaukee

Learning and Development program, Cultures & Contexts lab. Cumulative GPA 3.88

Preliminary Examination passed 7/31/16. Dissertation proposal defended 6/26/17.

Dissertation in progress on the topic of cultural socialization and Deaf identity development. Defense scheduled for July 2019 and graduation anticipated in August 2019.

August 2008. Master of Science, Educational Psychology, University of Wisconsin-Milwaukee

Learning and Development program. Cumulative GPA 3.85

May 2006. Bachelor of Arts, University of Wisconsin-Oshkosh

Majors: Psychology and Spanish; Minor: Business Administration (Human Resources emphasis). Cumulative GPA 3.47

May 2003. Associate of Arts and Sciences, University of Wisconsin-Sheboygan

Cumulative GPA 3.46. Received award for excellence in tutoring (psychology).

Teaching Experience

2019-Present. Lecturer. University of Wisconsin-Oshkosh, Fond du Lac campus.

Teaching general and developmental psychology courses to adult students.

2011 – 2016. Associate Lecturer/Instructional Academic Staff. University of Wisconsin Colleges- Sheboygan and Fond du Lac campuses.

Taught introductory and developmental psychology courses to adult students. Courses taught: Introduction to Psychology, Childhood and Adolescence, Lifespan Development, and Educational Psychology

2009 – 2011 Adjunct Faculty- General Education, Psychology. Lakeshore Technical College

Taught introductory and developmental psychology courses to adult students in traditional classroom setting and via interactive television (ITV) with remote classrooms. Taught via Angel and Blackboard online teaching platforms. Wisconsin Technical System Board certified.

Professional Experience

May 2008- Oct 2011. Social Worker III, M.S., Child Protective Services Intake. Sheboygan County Health and Human Services Department

Investigated allegations of child abuse and neglect. Interviewed children and adults. Completed family and safety assessments. Made referrals to community resources and case management. Performed Juvenile Court Intake. Social Work License #10759-120 (expired).

Research Presentations

2019 American Psychological Association Conference; Chicago, IL.

Husting, M. (August 2019). Hearing Parents and Deaf Cultural Identity Development. Psych Science in 3 speaking competition

Husting, M. & Nguyen, J. (August 2019). The Family Ethnic Socialization Measure Applied to a Sample of Deaf/ Hard of Hearing Emerging Adults. Poster presentation accepted.

2019 Midwestern Psychological Association Conference; Chicago, IL

Husting, M. & Nguyen, J (April 2019). Acculturation in Deaf/Hard of Hearing: Antecedents and Psychosocial Outcomes. Paper presentation.

Husting, M. and Nguyen, J. (April 2019). Deaf Acculturation, Depression/Anxiety, and Relationships with Parents: Unexpected Findings. Poster accepted.

2019 Society for Research in Child Development Conference; Baltimore, MD

Husting, M. & Nguyen, J. (March 2019). Parents' Hearing Status versus Deaf Cultural Socialization as Predictor of Cultural Identity and Psychosocial Outcomes. Poster presentation. *Nominated for a Student and Early Career Council poster competition award.

Husting, M. & Nguyen, J. (March 2019). Deaf Cultural Socialization as a Predictor of Deaf Cultural Identity, Self-Esteem, and Satisfaction with Life. Poster presentation.

2019 Early Hearing Loss Detection and Intervention Conference; Chicago, IL

Husting, M. & Nguyen, J. (March 2019). Parents' use of ASL predicts well-being and cultural identity development: A quantitative study of emerging adults who are deaf and hard of hearing. Poster presentation.

2017 Society for Research in Child Development Conference; Austin, TX

Husting, M. & Nguyen, J. (April 2017). Hearing Parents' and Deaf Cultural Socialization. Poster presentation.

2015 University of Wisconsin-Milwaukee School of Education Research Gala; Milwaukee, WI

Husting, M. & Nguyen, J. (April 2017). Deaf cultural Orientations and Socialization. Poster presentation.

Research Experience

2016-2019. Dissertation Research: Deaf Cultural Socialization: Exploring the Role of Parents in Deaf Cultural Identity Development.

Applying the ethnic-racial identity framework to the Deaf population, I developed the construct and associated measure of Deaf Cultural Socialization. An online survey of approximately 400 deaf and hard of hearing emerging adults measured the retrospective reports of parental engagement in socialization regarding the Deaf culture. Results indicate that Deaf Cultural Socialization predicts cultural identity and well-being, regardless of parents' hearing status. Papers in progress.

2013-2015. Thesis Research: Deaf Identity and Cultural Socialization: Perspectives and Practices of Hearing Parents of Deaf and Hard of Hearing Children.

Conducted semi-structured interviews with parents of deaf and hard of hearing children. Conducted qualitative and quantitative analyses of the results. Two papers in progress.

2012-2013. Research Assistant to Major Advisor: Jacqueline Nguyen

Assisted my advisor in her work on multicultural identities. Duties included preparing recruitment materials, managing participant communications in Qualtrics, developing a codebook, and data management.

Summer 2006. Interdisciplinary Psychology Research Study Abroad; Czech Republic.

Study abroad experience with interdisciplinary research teams composed of criminology, law, and psychological backgrounds.

Winter 2006. Observational Psychology Research Study Abroad; Belize.

Study abroad winterim in Belize studying Black Howler Monkeys in their natural habitat.

Summer 2005. Cross-cultural Psychology Research Study Abroad; Brazil.

Studying and conducting cross-cultural psychological research at Cultural Association between Brazil and the United States (ACBEU) institute. Researched cross-cultural preferences for facial symmetry with students from Brazil and the United States.

Service

2013. Founding president of the Educational Psychology Student Association (EPSA) at the University of Wisconsin- Milwaukee.

Awards and Recognition

August 2019. Finalist: Psych Science in 3 speaking competition. American Psychological Association Convention.

March 2019. Finalist: Student and Early Career Council poster competition. Society for Research in Child Development conference.

March 2019. Travel award: University of Wisconsin-Milwaukee Urban Education Doctoral Student Travel Award for EHDI conference.

March 2019. Travel award: University of Wisconsin-Milwaukee Graduate School Travel Award for SRCD conference.

March 2019. Travel award: Society for Research in Child Development Early Career Travel Award for SRCD conference.

March 2017. Travel award: University of Wisconsin-Milwaukee Graduate School Travel Award for SRCD conference.

March 2017. Travel award: University of Wisconsin-Milwaukee Graduate School Travel Award for SRCD conference.